

PERMIT DRAWING

220218 / 1 OF 4

PO Box 4590 | 204 Campus Way Modesto Ca 95350 | O 209.524.4484 | F 209.521.0272 | Ca LIC#268001 | C-45 | Nv Lic#0082570 | C-6



**NOTICE TO THE CUSTOMER**

Note: The colors depicted on this rendering may not match actual colors used on the finished display. Please refer to the detail drawing for the approved color specifications. Note: The cost of providing electrical wiring to the sign area, all required permits and all special inspections are not included in this sign proposal. Note: The proportion of signs shown on building & landscape area photos is an approximate representation.

**CUSTOMER APPROVAL**

ACCEPTED W/ NO CHANGES     ACCEPTED W/ CHANGES AS NOTED

REVISE AS NOTED AND RESUBMIT

BY \_\_\_\_\_ CUSTOMER    BY \_\_\_\_\_ LANDLORD

DATE \_\_\_\_\_    DATE \_\_\_\_\_

DATE	BY	DATE	BY
06.08.22	VT	.22	VT

**COMPANY OR JOB NAME / JOB DESCRIPTION**    220218

**ARCO SIGN PROGRAM**

ADDRESS:    1001 SAN PABLO AVENUE ALBANY CALIFORNIA 94706

SALESPERSON: HOUSE    CUSTOMER CONTACT: XXXXX

**© COPYRIGHT 2022** This drawing was created to assist you in visualizing our proposal. The original ideas herein are the property of Sign Designs. Permission to copy or revise this drawing can only be obtained thru a written agreement w/ Sign Designs. See your sales representative or call Sign Designs.

By signing this drawing document, I understand that I am not obligated to purchase this project, notwithstanding, the above artwork cannot be submitted for pricing, duplication and/or manufacturing to another sign company, architectural company or other business entity for the purpose or intent of manufacturing or for use as intellectual property, such as, but not limited to, a company logo, unless the represented logo was provided to Sign Designs by the customer and input into this drawing document by a Sign Designs employee.

NAME / DATE    I OF 4

This sign is intended to be installed in accordance with the requirements of ARTICLE 600 of the national electrical code &/or other applicable codes. this includes proper grounding & bonding of the sign. The location of the disconnect switch after installation shall comply w/ ARTICLE 600.6(A)(1) of the National Electrical Code. All measures shown in this drawing are nominal until the "NOT FOR PRODUCTION" is removed

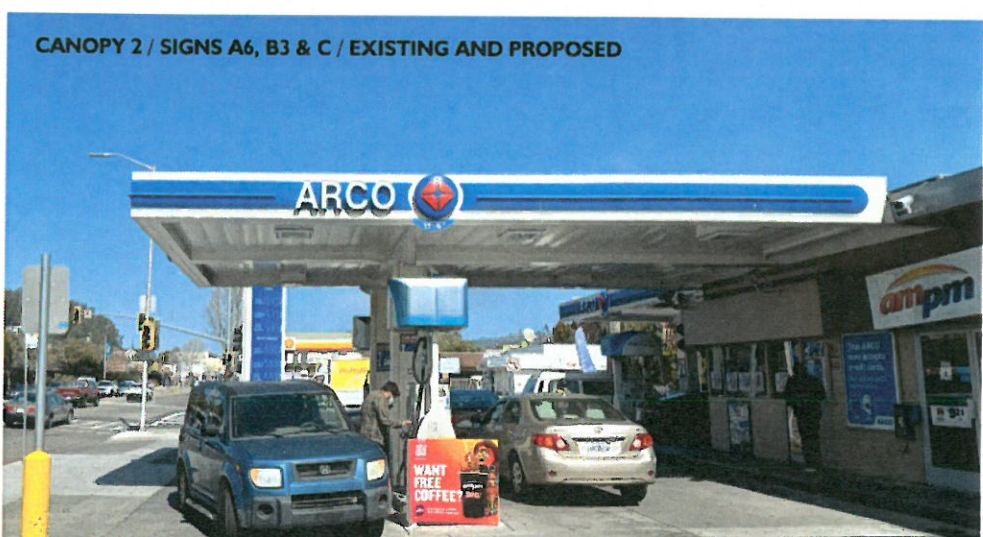
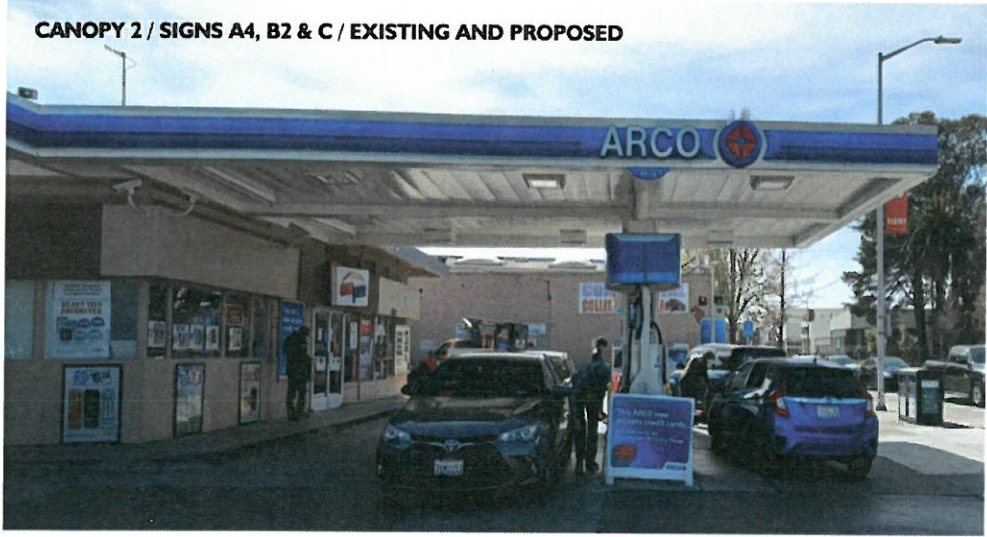
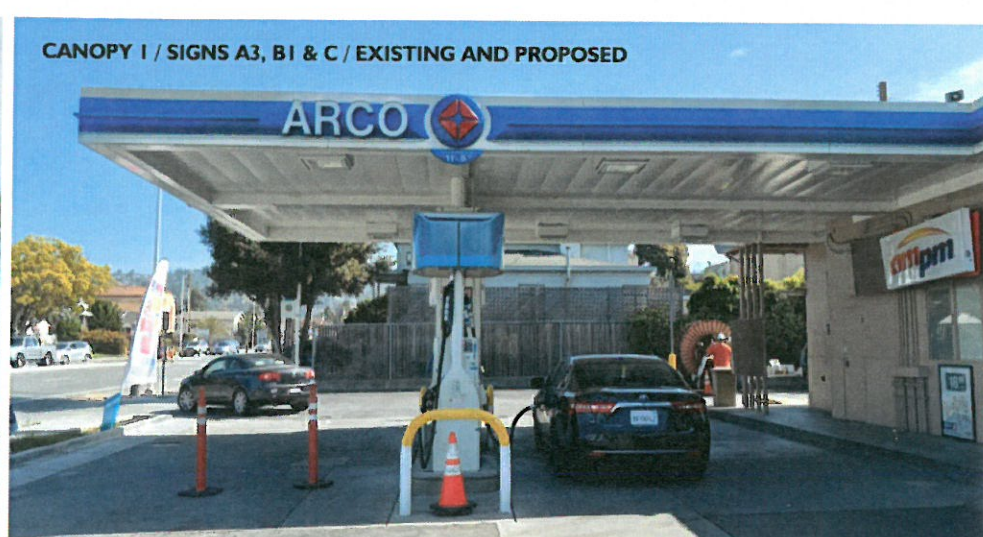
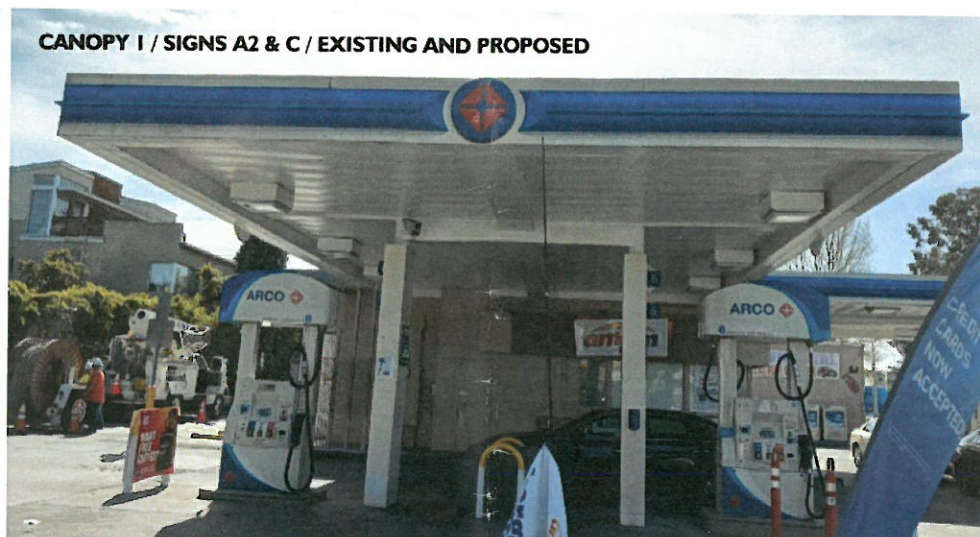
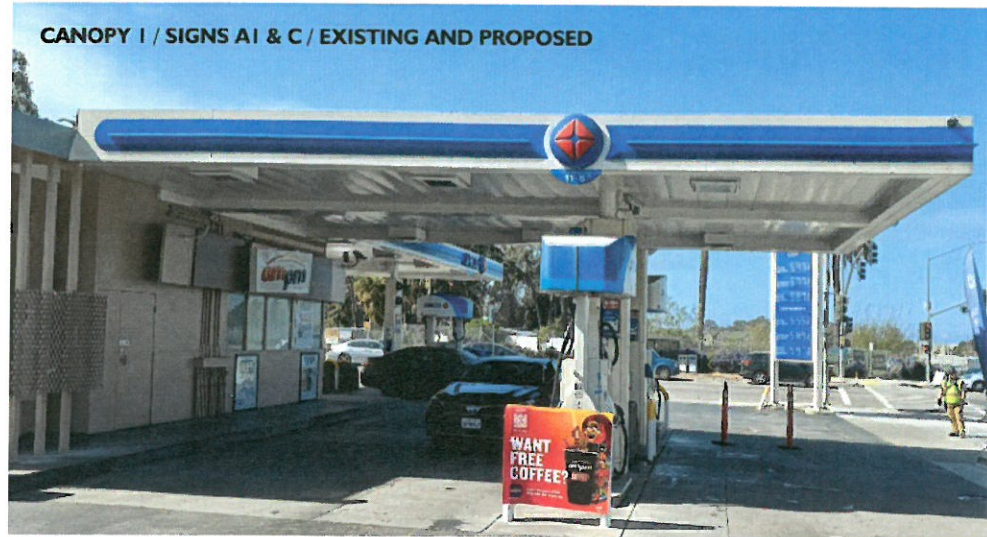

**NOTE: ALL SIGNAGE TO BE REPLACED LIKE FOR LIKE. NO CHANGES TO SIZES, COLORS, LAYOUT, ILLUMINATION OR SQUARE FOOTAGE.**

PERMIT DRAWING

**SDI SIGN DESIGNS** INCORPORATED

PO Box 4590 | 204 Campus Way Modesto Ca 95350 | O 209.524.4484 | F 209.521.0272 | Ca LIC#268001 | C-45 | Nv Lic#0082570 | C-6

<p><b>NOTICE TO THE CUSTOMER</b></p> <p>Note: The colors depicted on this rendering may not match actual colors used on the finished display. Please refer to the detail drawing for the approved color specifications. Note: The cost of providing electrical wiring to the sign area, all required permits and all special inspections are not included in this sign proposal. Note: The proportion of signs shown on building &amp; landscape area photos is an approximate representation.</p>	<p><b>CUSTOMER APPROVAL</b></p> <p><input type="checkbox"/> ACCEPTED W/ NO CHANGES    <input type="checkbox"/> ACCEPTED W/ CHANGES AS NOTED</p> <p><input type="checkbox"/> REVISE AS NOTED AND RESUBMIT</p>		<p>DATE</p> <p>06.08.22</p>	<p>BY</p> <p>VT</p>	<p>DATE</p> <p>.22</p>	<p>BY</p> <p>VT</p>	<p><b>COMPANY OR JOB NAME / JOB DESCRIPTION</b></p> <p>220218</p>
	<p>BY <u>CUSTOMER</u>    BY <u>LANDLORD</u></p> <p>DATE _____    DATE _____</p>	<p>ADDRESS: <b>1001 SAN PABLO AVENUE ALBANY CALIFORNIA 94706</b></p>		<p>SALESPERSON: <b>HOUSE</b></p>		<p>CUSTOMER CONTACT: <b>XXXXXX</b></p>	
<p>© <b>2022</b> COPYRIGHT</p> <p>This drawing was created to assist you in visualizing our proposal. The original ideas herein are the property of Sign Designs. Permission to copy or revise this drawing can only be obtained through a written agreement w/ Sign Designs. See your sales representative or call Sign Designs.</p>	<p>By signing this drawing document, I understand that I am not obligated to purchase this project, notwithstanding, the above artwork cannot be submitted for pricing, duplication and/or manufacturing to another sign company, architectural company or other business entity for the purpose or intent of manufacturing or for use as intellectual property, such as, but not limited to, a company logo, unless the represented logo was provided to Sign Designs by the customer and input into this drawing document by a Sign Designs employee.</p>						<p><b>2 OF 4</b></p>

This sign is intended to be installed in accordance with the requirements of ARTICLE 600 of the national electrical code &/or other applicable codes. this includes proper grounding & bonding of the sign. The location of the disconnect switch after installation shall comply w/ ARTICLE 600.6(A)(1) of the National Electrical Code. All measures shown in this drawing are nominal until the "NOT FOR PRODUCTION" is removed

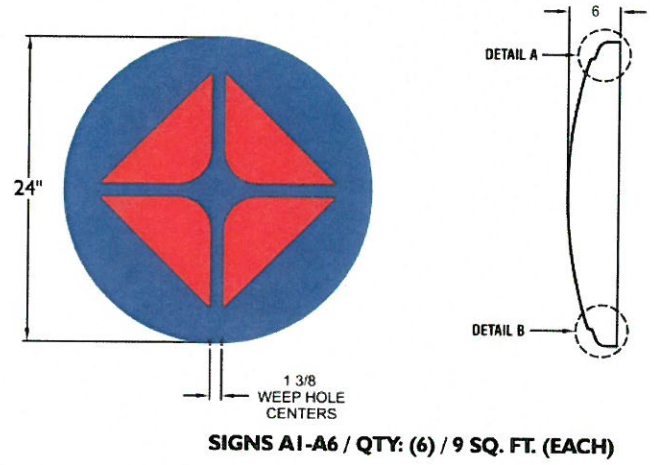

SIGNS A1-A6 / QTY: (6) / 9 SQ. FT. (EACH)

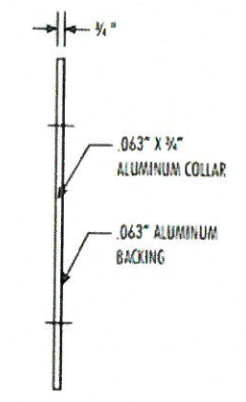

SIDE VIEW  
BACKING

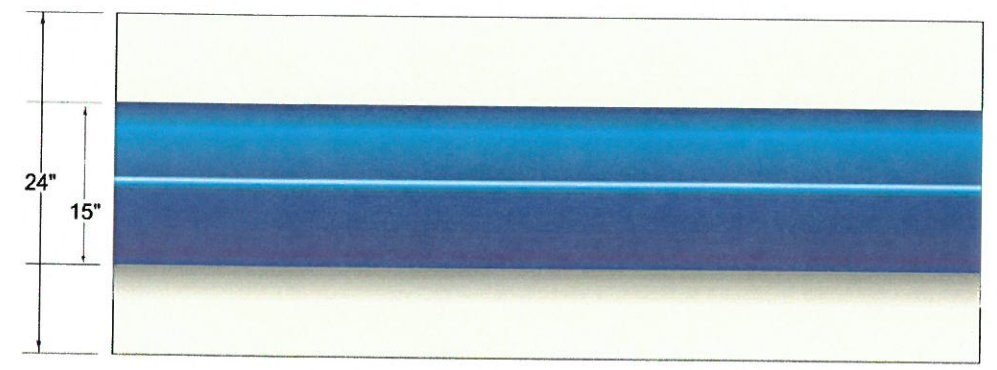

SIGN C: CANOPY FASCIA WITH LIGHTBAR  
NOT TO SCALE

SCOPE OF WORK: RECEIVE AND INSTALL FUEL CANOPY FASCIA WITH LIGHTBAR

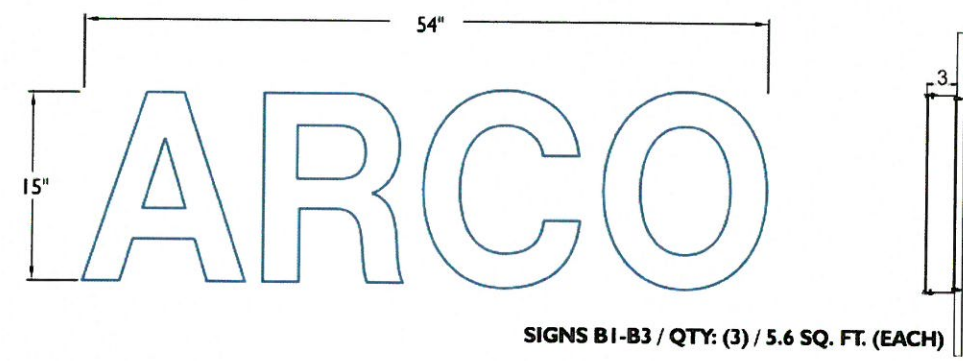

SIGNS B1-B3 / QTY: (3) / 5.6 SQ. FT. (EACH)

SIGNS A1-A6, & B1-B3: PAN CHANNEL LETTERS & LOGO  
NOT TO SCALE  
MATERIALS: ACRYLIC/POLYCARBONATE, ALUMINUM  
ILLUMINATION: LEDS

SCOPE OF WORK: RECEIVE AND INSTALL PAN CHANNEL CANOPY SIGNAGE

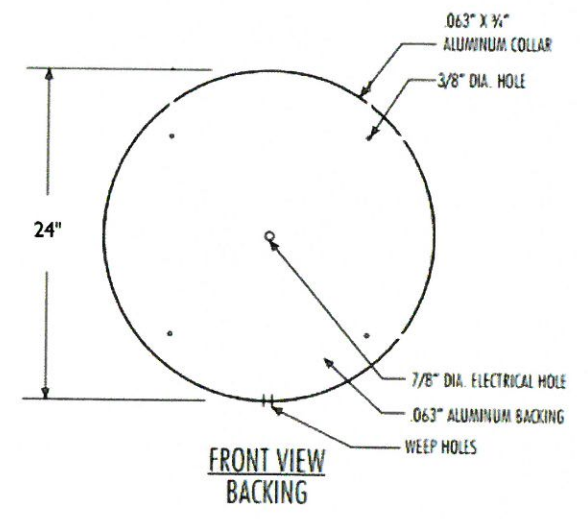

FRONT VIEW  
BACKING

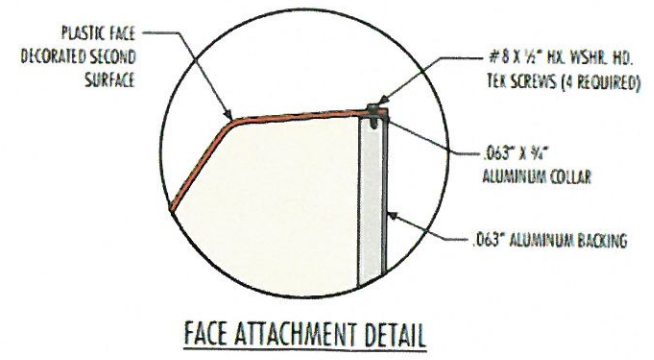
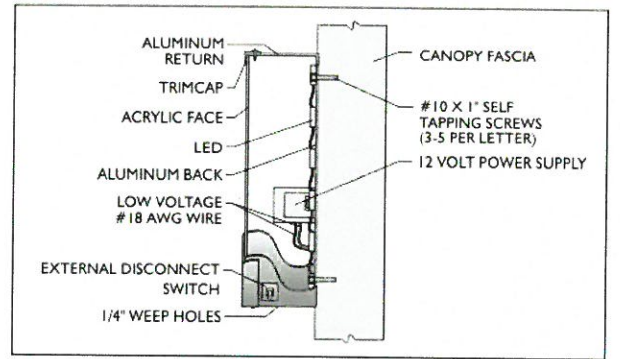

FACE ATTACHMENT DETAIL

PERMIT DRAWING 220218 / 3 OF 4

<b>NOTICE TO THE CUSTOMER</b> <small>Note: The colors depicted on this rendering may not match actual colors used on the finished display. Please refer to the detail drawing for the approved color specifications. Note: The cost of providing electrical wiring to the sign area, all required permits and all special inspections are not included in this sign proposal. Note: The proportion of signs shown on building &amp; landscape area photos is an approximate representation.</small>	<b>CUSTOMER APPROVAL</b> <input type="checkbox"/> ACCEPTED W/ NO CHANGES <input type="checkbox"/> ACCEPTED W/ CHANGES AS NOTED <input type="checkbox"/> REVISE AS NOTED AND RESUBMIT		DATE: 06.08.22 BY: VT	DATE: .22 BY: VT	COMPANY OR JOB NAME / JOB DESCRIPTION <b>ARCO SIGN PROGRAM</b>	<b>220218</b>
	BY: CUSTOMER    BY: LANDLORD DATE: _____    DATE: _____	ADDRESS: 1001 SAN PABLO AVENUE ALBANY CALIFORNIA 94706		SALESPERSON: HOUSE    CUSTOMER CONTACT: XXXXXX		NAME / DATE _____

**COPYRIGHT 2022** This drawing was created to assist you in visualizing our proposal. The original ideas herein are the property of Sign Designs. Permission to copy or revise this drawing can only be obtained thru a written agreement w/ Sign Designs. See your sales representative or call Sign Designs.

By signing this drawing document, I understand that I am not obligated to purchase this project, notwithstanding, the above artwork cannot be submitted for pricing, duplication and/or manufacturing to another sign company, architectural company or other business entity for the purpose or intent of manufacturing or for use as intellectual property, such as, but not limited to, a company logo, unless the represented logo was provided to Sign Designs by the customer and input into this drawing document by a Sign Designs employee.

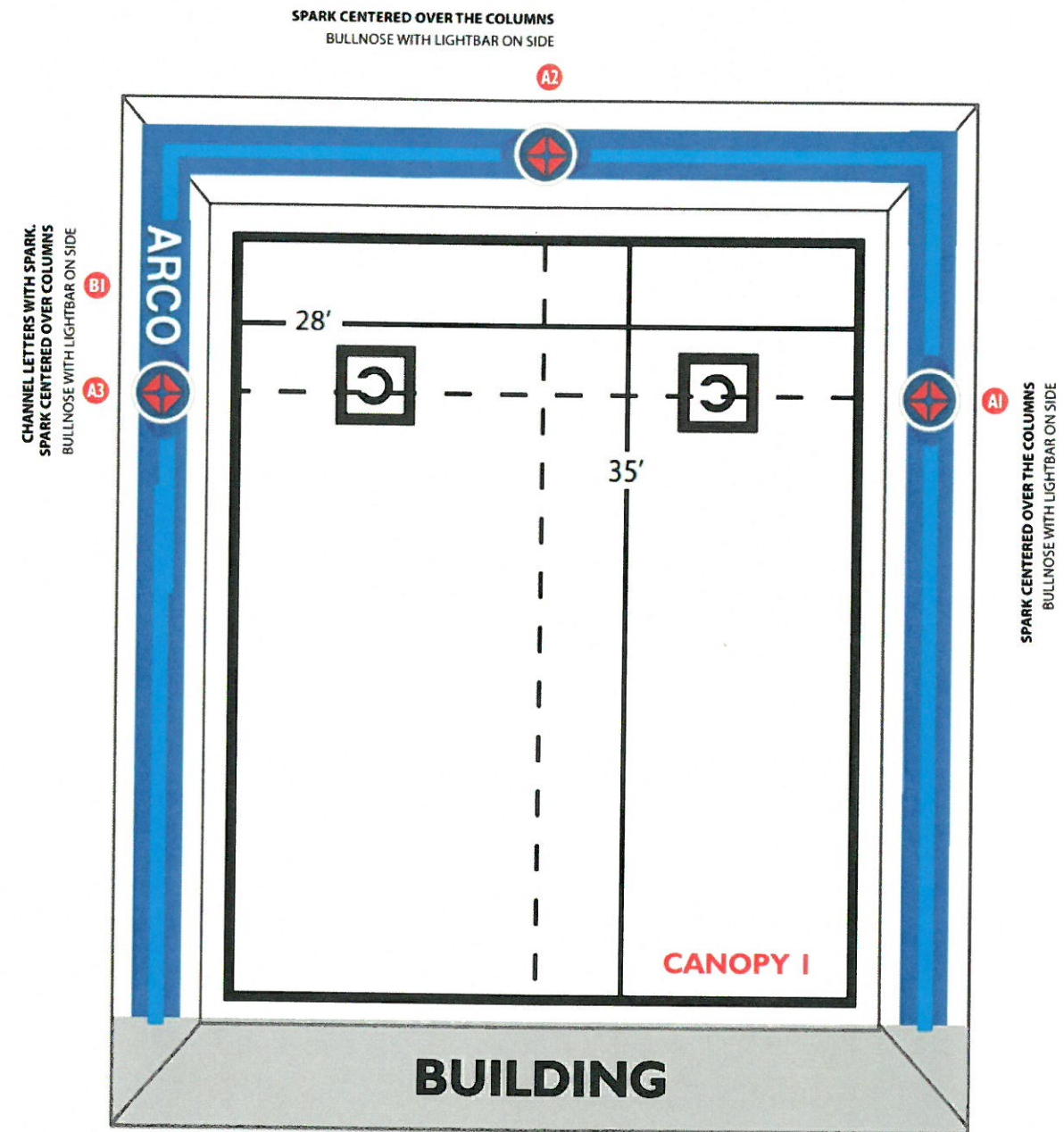
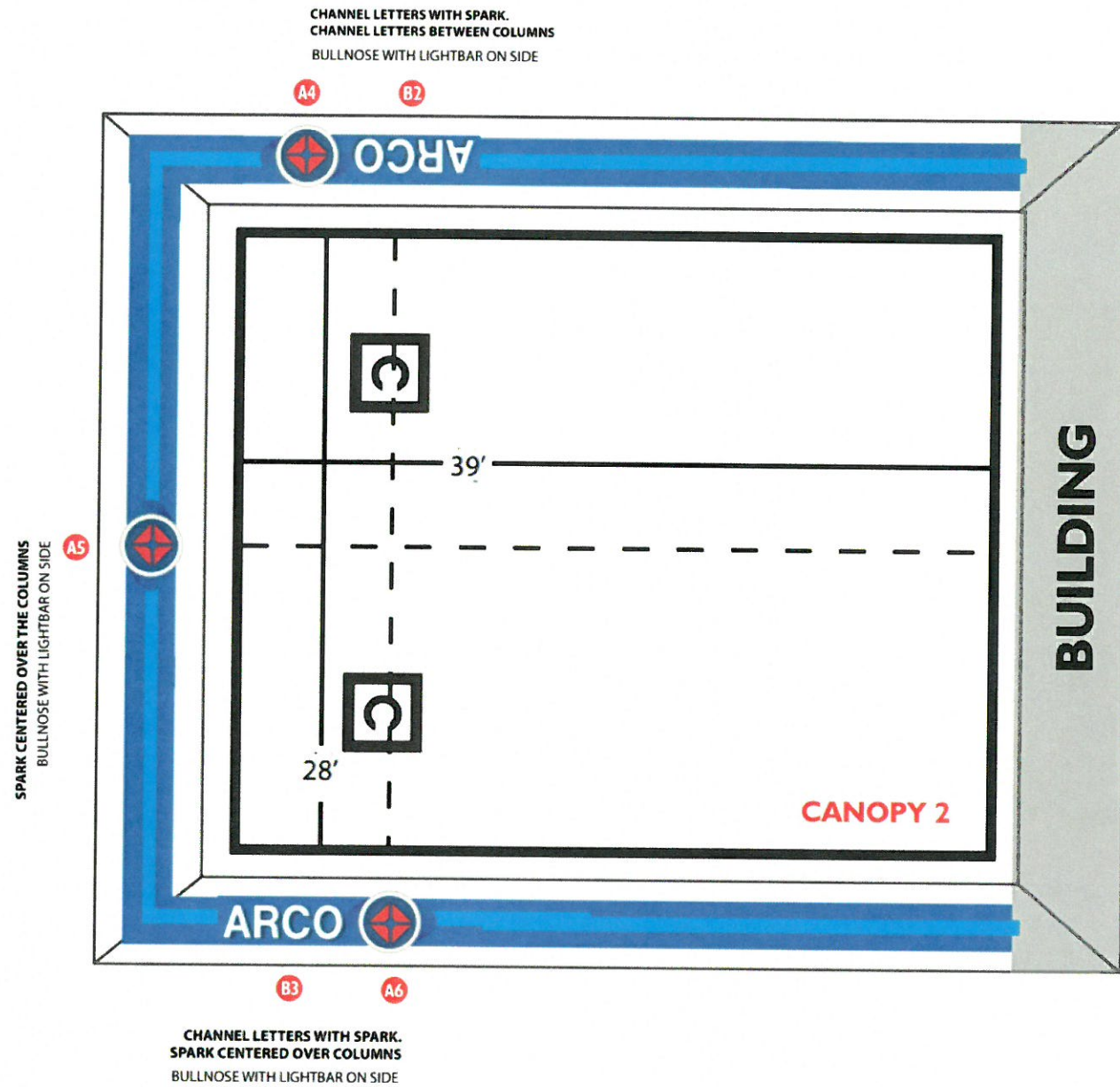

**SDI SIGN DESIGNS**

INCORPORATED

PO Box 4590 | 204 Campus Way Modesto Ca 95350 | O 209.524.4484 | F 209.521.0272 | Ca LIC#268001 | C-45 | Nv LIC#0082570 | C-6



**NOTICE TO THE CUSTOMER**

Note: The colors depicted on this rendering may not match actual colors used on the finished display. Please refer to the detail drawing for the approved color specifications. Note: The cost of providing electrical wiring to the sign area, all required permits and all special inspections are not included in this sign proposal. Note: The proportion of signs shown on building & landscape area photos is an approximate representation.

**CUSTOMER APPROVAL**

ACCEPTED W/ NO CHANGES     ACCEPTED W/ CHANGES AS NOTED

REVISE AS NOTED AND RESUBMIT

BY CUSTOMER    BY LANDLORD

DATE \_\_\_\_\_    DATE \_\_\_\_\_

DATE	BY	DATE	BY
06.08.22	VT	.22	VT

**COMPANY OR JOB NAME / JOB DESCRIPTION**    **220218**

**ARCO SIGN PROGRAM**

ADDRESS: **1001 SAN PABLO AVENUE ALBANY CALIFORNIA 94706**

SALESPERSON: **HOUSE**    CUSTOMER CONTACT: **XXXXXX**

NAME / DATE    **4 OF 4**