



## ARTS COMMITTEE

City Hall Council Chambers  
1000 San Pablo Avenue, Albany, CA

---

### AGENDA

Monday, October 8, 2018 - 7:00 PM  
Albany City Hall Council Chambers

**1. CALL TO ORDER / ROLL CALL**

**2. APPROVAL OF MINUTES:** Monday, September 17, 2018

**3. PUBLIC COMMENT**

For persons desiring to address the Commission/Committee/Board on an item that is not on the agenda please note that each speaker is limited up to three (3) minutes. The Brown Act limits the Committee's ability to take and/or discuss items that are not on the agenda; therefore, such items are normally referred to staff for comment or to a future agenda.

**4. ANNOUNCEMENTS**

Staff and Committee member announcements, reports and updates of status of previous agenda items.

**4-1. Invitation to Advisory Body Members Appreciation Evening**

DATE: Thursday, October 18, 2018

TIME: 7:00 PM – 8:30 PM

PLACE: Albany Community Center, 1249 Marin Avenue, Albany

**5. PRESENTATIONS**

**5-1. Community Development** – Community Development Department staff will provide an update to the Arts Committee on pending development applications including:

- 949 San Pablo Ave.
- Portland Kains Townhouses
- Satellite Affordable Housing Associates project at Cleveland & Washington

Staff will also provide an update on the Solano Avenue Complete Streets Plan.

**5-2. Creek Art** – Artist will provide an update on the Creek Art project and additional funds needed.

**Recommendations:** Discuss and make a motion to approve additional funding

**Attachments:** Artist's Design to Build

**5-3. Blue Bear School of Rock**



## ARTS COMMITTEE

City Hall Council Chambers  
1000 San Pablo Avenue, Albany, CA

---

### 6. DISCUSSION & POSSIBLE ACTION ON MATTERS RELATED TO THE FOLLOWING ITEMS:

- 6-1. Community Projects** – The Committee will review proposed mural locations from Ximena Soza/Cristian Munoz.

***Recommendation:** Discuss and make a motion to approve or deny the proposed Community Projects mural location*

***Attachments:** Community Projects proposal*

- 6-2. Sculpture Loan Program** – Members Goodman and Holland will provide an update on the Sculpture Loan Program.

***Recommendation:** Receive information and discuss.*

- 6-3. Albany Community Center Foyer Gallery** – Member Black will update the Committee on the Community Center Foyer Gallery

***Recommendation:** Information only*

- 6-4. Fall into Haiku** – Member Goodman will provide an update on the Fall into Haiku program.

***Recommendation:** Information only*

- 6-5. Albany FilmFest** - Member Goodman will provide an update on the Albany FilmFest.

***Recommendation:** Information only*

### 7. FUTURE AGENDA ITEMS

Committee members announce requests for future agenda items. No public comment will be taken on announcement of future agenda items.

- 8. NEXT MEETING:** Tuesday, November 13, 2018 at 7:30 pm, Albany Community Center, 1249 Marin Ave.

### 9. ADJOURNMENT

As a general policy, the Commission/Committee/Board will not begin discussion or consideration of an agenda item after 10:00 pm.



## ARTS COMMITTEE

City Hall Council Chambers  
1000 San Pablo Avenue, Albany, CA

---

The Arts Committee agenda is available for public inspection at City Hall, the Albany Community Center, and the Albany Senior Center. The agenda and supporting staff reports can also be found online at: [www.albanyca.org](http://www.albanyca.org). If you have any questions pertaining to any agenda item or Council meeting procedure, please contact the City Clerk's Office at 528-5710.

Agenda related writings or documents provided to the City Council regarding any item on this agenda will be made available for public inspection in the lobby of City Hall.

Council and Commission meetings are broadcast live on KALB and streamed live on the City website and YouTube. Committee meeting audio is recorded and uploaded to the City website and YouTube and within one week of each public meeting. Archives of past City meetings are available on the City website and YouTube. Please note that if you provide your name and address when speaking before the City Council it will become part of the official public record, which will be posted on the Internet and broadcast on KALB.

The City of Albany is dedicated to maintaining its small-town ambience, responding to the needs of a diverse community, and providing a safe, healthy and sustainable environment.

### NOTICE

Pursuant to Government Code Section 65009, if you challenge a decision of the Commission in court, you may be limited to raising only those issues you or someone else raised at a public hearing described in this notice, or in written correspondence delivered to the City Council at, or prior to, the public hearing.

The decision of the City Council is final as of the date of its decision unless judicial review is initiated pursuant to California Code of Civil Procedure Section 1094.5. Any such petition for judicial review is subject to the provisions of California Code of Civil Procedure 1094.6.

In compliance with the Americans with Disabilities Act (ADA), and State Law, if you need special assistance to participate in this meeting, please contact the City Administration Office 510-528-5710. Notification 48 hours prior to the meeting will enable the City to make reasonable arrangements to ensure accessibility to this meeting (28 CFR 35.102.104 ADA Title II)". Upon request, we will provide written agenda materials in appropriate alternate formats, of disability related modification or accommodation, including auxiliary aids or services to enable individuals with disabilities to participate in public meetings. Please deliver a written request, including your name, mailing address, phone number and brief description of the requested materials and preferred alternative format or auxiliary aid or service at least two (2) days before the meeting. Request should be sent to: [cityclerk@albanyca.org](mailto:cityclerk@albanyca.org) or City Clerk, 1000 San Pablo Avenue, Albany, CA 94706.



## ARTS COMMITTEE

City Hall Council Chambers  
1000 San Pablo Avenue, Albany, CA

---

### MINUTES

Monday, September 17, 2018 - 7:00 PM  
Albany Community Center, Edith Stone Room

#### 1. CALL TO ORDER / ROLL CALL – 7:18pm

**Present:** Chair Daly, Members Black, Goodman and Holland

**Absent:** Members Komaromi, Moffat and Schneider

#### 2. APPROVAL OF MINUTES: July Meeting 2018

**Motion:** A motion was made by Member Black and seconded by Member Goodman to approve the July 2018 meeting action minutes.

**Ayes:** Chair Daly, Members Black, Goodman and Holland

**Noes:** None

**Abstain:** None

The motion carries and so ordered.

#### 3. PUBLIC COMMENT

For persons desiring to address the Commission/Committee/Board on an item that is not on the agenda please note that each speaker is limited up to three (3) minutes. The Brown Act limits the Committee's ability to take and/or discuss items that are not on the agenda; therefore, such items are normally referred to staff for comment or to a future agenda.

#### 4. ANNOUNCEMENTS

Staff and Committee member announcements, reports and updates of status of previous agenda items.

**4-1. Dinner with Albany (September 29)** – thanked our Table Decoration Judges (Chair Daly and Members Holland and Black)

**4-2. Albany Local Week (September 21-29)** - Update

**4-3. Music in the Park (Wednesdays in September)** - Update

**4-4. Best of Albany (everythingalbany.com)** – VOTE! *Best Gallery Space*

**4-5. Invitation to Advisory Body Members Appreciation Evening**

DATE: Thursday, October 18, 2018

TIME: 7:00 PM – 8:30 PM

PLACE: Albany Community Center, 1249 Marin Avenue, Albany



## ARTS COMMITTEE

City Hall Council Chambers  
1000 San Pablo Avenue, Albany, CA

---

### 5. PRESENTATIONS

### 6. DISCUSSION & POSSIBLE ACTION ON MATTERS RELATED TO THE FOLLOWING ITEMS:

**6-1. Creek Art** – Artist was not present when this agenda item was being discussed so the Committee agreed to move item to the end of the agenda (6-7). Artist had not arrived by the conclusion of the meeting, so agenda items was postponed to October meeting.

**6-2. Community Projects** –The Committee reviewed the proposal from artists, Ximena Soza and Cristian Munoz.

**Motion:** A motion was made by Member Black and seconded by Member Goodman to approve a grant of \$10,000 to Ximena Soza and Christian Munoz’s to create a mural in a site to be determined.

**Ayes:** Chair Daly, Members Black, Goodman and Holland

**Noes:** None

**Abstain:** None

The motion carries and so ordered.

**6-3. Albany Community Center Foyer Gallery** - The Committee reviewed ten applications for the 2019 Community Center Gallery and selected four.

**Motion:** A motion was made by Member Black and seconded by Member Holland to approve the artwork of Julia James, Betsy Kendall, Ora Clay and Lisa Levin for the 2019 Community Center Foyer Gallery.

**Ayes:** Chair Daly, Members Black, Goodman and Holland

**Noes:** None

**Abstain:** None

The motion carries and so ordered.

**6-4. Sculpture Loan Program** – Members Goodman and Holland provided an update on the three selected Ohlone Greenway sculpture locations.

**6-5. Fall into Haiku** – Member Goodman provided an update on the Fall into Haiku program.

**6-6. Albany FilmFest** - Member Goodman provided an update on the Albany FilmFest.



## ARTS COMMITTEE

City Hall Council Chambers  
1000 San Pablo Avenue, Albany, CA

---

### 7. FUTURE AGENDA ITEMS

Fall into Haiku, Blue Bear Music School of Rock, Community Center Foyer Gallery, Creek Art, Community Projects, Sculpture Loan Program

### 8. NEXT MEETING: Monday, October 8, 2018 at 7:00 pm, City Hall Council Chambers, 1000 San Pablo Ave.

### 9. ADJOURNMENT – 8:48 pm

As a general policy, the Commission/Committee/Board will not begin discussion or consideration of an agenda item after 10:00 pm.

The Arts Committee agenda is available for public inspection at City Hall, the Albany Community Center, and the Albany Senior Center. The agenda and supporting staff reports can also be found online at: [www.albanyca.org](http://www.albanyca.org). If you have any questions pertaining to any agenda item or Council meeting procedure, please contact the City Clerk's Office at 528-5710.

Agenda related writings or documents provided to the City Council regarding any item on this agenda will be made available for public inspection in the lobby of City Hall.

Council and Commission meetings are broadcast live on KALB and streamed live on the City website and YouTube. Committee meeting audio is recorded and uploaded to the City website and YouTube and within one week of each public meeting. Archives of past City meetings are available on the City website and YouTube. Please note that if you provide your name and address when speaking before the City Council it will become part of the official public record, which will be posted on the Internet and broadcast on KALB.

The City of Albany is dedicated to maintaining its small-town ambience, responding to the needs of a diverse community, and providing a safe, healthy and sustainable environment.

### NOTICE

Pursuant to Government Code Section 65009, if you challenge a decision of the Commission in court, you may be limited to raising only those issues you or someone else raised at a public hearing described in this notice, or in written correspondence delivered to the City Council at, or prior to, the public hearing.

The decision of the City Council is final as of the date of its decision unless judicial review is initiated pursuant to California Code of Civil Procedure Section 1094.5. Any such petition for judicial review is subject to the provisions of California Code of Civil Procedure 1094.6.

In compliance with the Americans with Disabilities Act (ADA), and State Law, if you need special assistance to participate in this meeting, please contact the City Administration Office 510-528-5710. Notification 48 hours prior to the meeting will enable the City to make reasonable arrangements to ensure accessibility to this meeting (28 CFR 35.102.104 ADA Title II)". Upon request, we will provide written agenda materials in appropriate alternate formats, of disability related modification or accommodation, including auxiliary aids or services to enable individuals with disabilities to participate in public meetings. Please deliver a written request, including your name, mailing address, phone number and brief description of the requested materials and preferred alternative format or auxiliary aid or service at least two (2) days before the meeting. Request should be sent to: [cityclerk@albanyca.org](mailto:cityclerk@albanyca.org) or City Clerk, 1000 San Pablo Avenue, Albany, CA 94706.

## Implementation of "Creek Art" for the Ohlone Greenway

Accompanying diagrams and drawings graphically illustrate the installation typical of one of the three creek art installations along the Greenway and the other two are substantially the same for purposes of installation.

1. Demarcate the area for installation by cones and other city approved means of defining as well as closing off the site area to public access.
2. Construction crew, supervised by artists, to cut out of existing asphalt and remove, a rectangular section approximately 4'x6' in size, material to be disposed of in approved manner and taken to a construction dump site. Please note, we originally thought we would be able to construct the artistic portion of the work off site, thus reducing dramatically the time needed for on site disruption but the costs inherent in transporting and hoisting the finished art work has proved not to be cost effective.
3. Exposed area under asphalt to be graded level approximately 4" below grade. Concrete to be poured on location and screed level as a rectangular bed approximately 1" below grade and allowed to dry and cure for a period of about a week, or until suitable for succeeding layer of concrete aggregate mix.
4. Construction crew and artists will install network of bronze metal waves as approved in original application plus the requisite bronze plaque satisfying criteria listed in instructions acknowledging funding source, date, purpose of art, significance of location and identity of artists. The bronze material of all exposed metal will be environmentally durable for exterior exposure as per instructions of the art call. Anchoring material may be stainless steel and other durable materials and embedded in concrete requiring no maintenance.
5. Construction crew under artists' supervision, will pour on site around and under the bronze metal network, a finishing layer of colored concrete aggregate mix with effective long term durability of terrazzo. This surface must be cured and dried over a period of several days and thus will require continued isolation of area to general public to prevent hand prints and the like. This layer will be ground down to a rough texturized surface to provide a no skid texture to both concrete and metal. Detritus from grinding will be environmentally removed and may include sand from sandblasting if necessary. Exposed surface should be maintenance free.
6. Surface will be finished and presentable after this sequence of installation processes in each of three locations is completed, ending with finish grinding and/or sand blasting. At completion of work each site will be cleaned and ready for any opening event so scheduled.

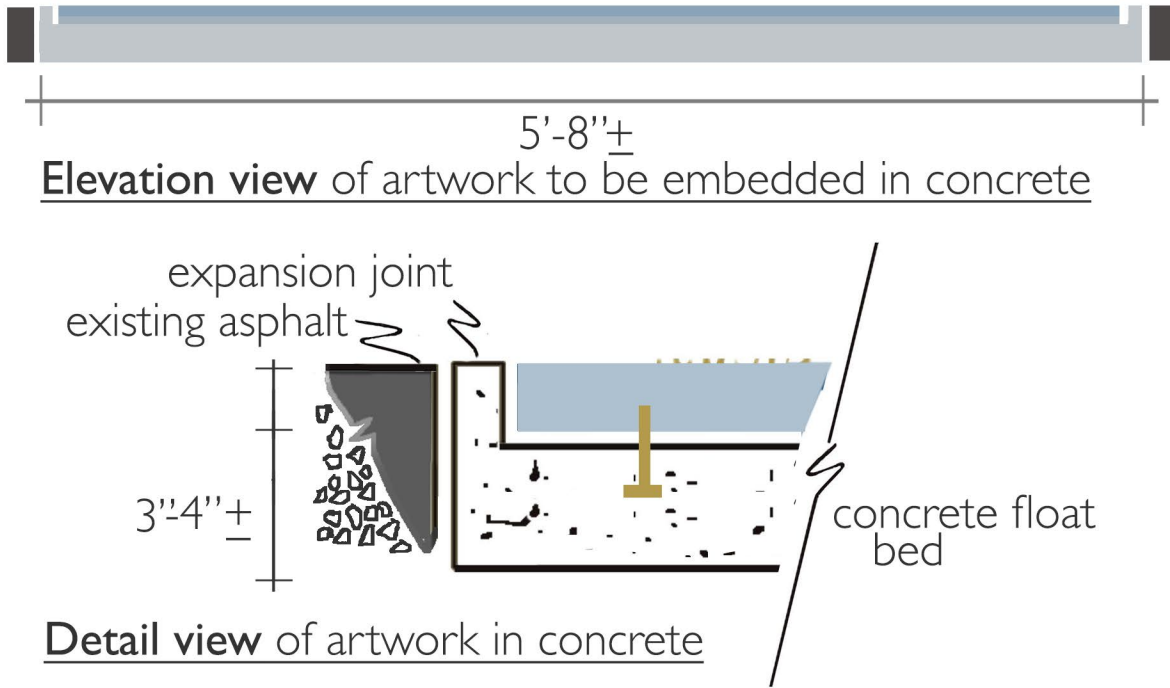

**Embed artwork in asphalt at 3 locations - float in soft concrete**

**Stage One - on site**

- Ia.** Contractor to cut into existing asphalt approx 5'-8" x 2'-10" by 4" deep a hole to embed each art panel.
- Ib.** Contractor to level bed and pour concrete to 1" below grade & screed flat. Remove debris in approved manner to a construction dump site.
- Ic.** Protect site while curing and drying with approved barriers and cones.

**Preparing Site for art installation on-site**

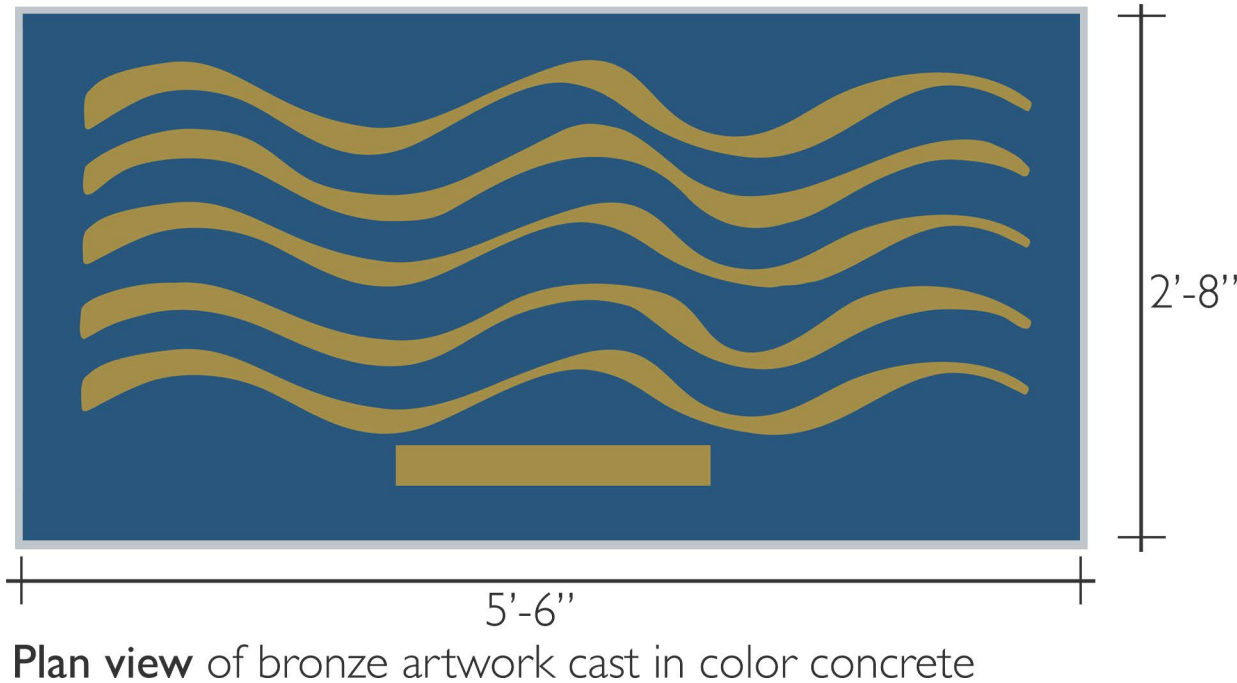

Bronze art with anchors to be embedded on site in molds approx 5'-6" x 2'-8" with dark blue colorization on top 1" and regular concrete to fill approx 3" base

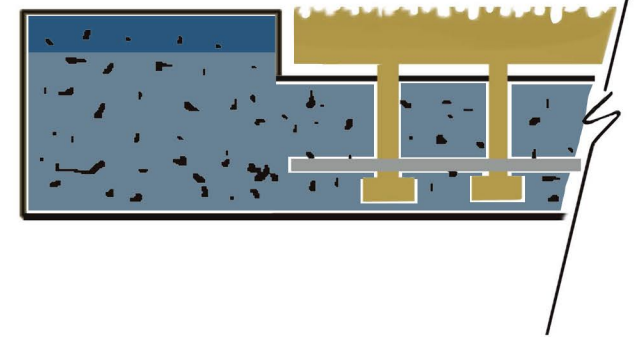

**Detail Elevation view of artwork**

**Stage Two - (similar to creating a countertop)**

- Ia.** Three identical pieces of bronze artwork will be provided with anchors at a depth of about 3" with a stabilization plate or wire mesh.
- Ib.** Contractor to pour into provided molds in 2 stages; base layer w/ rebar approx 3" thick, top layer of dark blue color concrete terrazzo approx 1" thick.
- Ic.** Contractor to grind and /or sand blast top layer to expose metal art and create textured non-slip surface.

**Casting Hidden Creeks art on-site in concrete**



## COMMUNITY ART PROJECT PROPOSAL

### APPLICANT INFORMATION

Primary Contact Name (Albany Resident): **XIMENA SOZA**  
 Applicant Group Name (optional): **-**  
 Name of Additional Group Members (optional): **- XIMENASOZAV@GMAIL.COM**  
 Primary Contact Email: \_\_\_\_\_ Phone: **510-9829124** Alternate Phone: **-**  
 Primary Contact Address: **1051 CASTRO ST. APT. 4**  
 City: **ALBANY** State: **CA** ZIP Code: **94706**

### ARTIST INFORMATION

Project Artist (or Lead Artist): **CRISTIAN MUNOZ**  
 Artist Email: \_\_\_\_\_ Artist Phone: **510-3028838** Alternate Phone: \_\_\_\_\_  
 Address: **1051 CASTRO ST. APT. 4**  
 City: **ALBANY** State: **CA.** ZIP Code: **94706**  
 List Any Additional Project Artists (optional): \_\_\_\_\_

### SITE INFORMATION

Description of Site: \_\_\_\_\_  
 Address: **SAN PABLO 860** Phone: **415-373 2352**  
 City: **ALBANY** State: **CA** ZIP Code: **94706**  
 Public Property (City of Albany)  Private Property (readily visible/accessible to the public)  
 Name of Private Property Owner: **LANI TORRES (CONTACT OWNER)**  
 Address: **860 SAN PABLO** Phone: **415 3732352**  
 City: **ALBANY** State: **CA .** ZIP Code: **94706**

### PROJECT SUMMARY

Summarize the proposed Art in Public Places project in 50 words or less:

### ATTACHMENT CHECKLIST

- Project Description (maximum 2 pages, 12-point font, 1" margins)
- Visual Documentation of Site and Proposed Design
- Project Budget (total budget including but not limited to this grant below \$10,000)
- Artist Resume or CV (include link to portfolio online if available)
- Letter of Commitment from Artist (optional)
- Evidence of Community Support

### SIGNATURES

I verify that all information contained in this proposal is true and correct to the best of my knowledge.

Signature:  Date: **JUNE 27 2018**  
 Name (printed): **CRISTIAN MUNOZ**

## **Debunking Stereotypes Through Muralism Art Project for Albany**

**Name of the Project:** Debunking Stereotypes Through Muralism

**Description of the Project:** The project Debunking Stereotypes Through Muralism is a public art project that combines art and issues of social justice, promoting diversity and a positive perspective, inclusion and representation of all community members. The project consists in the creation of a public mural that includes in its design, counter narratives developed by open dialogues with community members, regarding negative stereotypes promoted against ethnic, racial, religious or cultural groups. The point of the counter narrative is to show the opposite a stereotype suggests, in other words, the counter narrative proves a particular stereotype wrong.

The discussion about stereotypes and counter narratives will be developed by opening a dialog with a different actors of Albany's community members. This experience has been carried out, by us, in other communities with great success, the multidisciplinary expertise of our team will ensure a safe space for conversation.

Given the times we live in and previous events that have happened in Albany, we see as artists and community members the great need to use art to promote social values of respect, acceptance and inclusiveness. Also, strong cultural diversity is significant characteristic of Albany.

**Visual description of the Project:** The mural's design will be created after the conversations are carried with community members, it will also include designs that evoke that evoke music and nature, one, given to the characteristics of the sight and to the characteristics of Albany.

Besides the painting component, we would like to enhance the mural with a few small pieces of fused glass insects and birds. These inclusions would be permanent and totally secured within the mural. The glass pieces would be added with the technique of mosaic. There are not many murals in our area with tridimensional characteristics, this component will make our mural unique.

We are attaching work samples that show previous murals and previous pieces of fused glass.

**Proposed Site for the project:** The mural will be painted in the wall of the local music venue Ivy Room, located at 860 San Pablo Ave, Albany, CA 94706. Contact has been established with Mrs Lani Torres, who is thrilled to have the mural be painted by her store. The site goes in concordance with the sites the City of Albany Public Arts Master Plan intents to enhance.

**Activities that would be included in this project:**

- Community debunking stereotypes dialogue sessions. These sessions will be free and they will be held at different sites in Albany to ensure a diversity of participation. These sessions include a small presentation, followed by a dialogue about stereotypes and how we could represent a counter narrative for them in a mural.

- Gathering and analyzing the information gathered in the sessions to decide on the elements that would be included in the mural.
- Design the mural. the lead artist will create the design of a mural that includes the counter narratives created by the participants
- Prepare the wall. Polish, prime the wall
- Drawing of the mural.
- Community painting days. The project will offer an opportunity for community members to participate painting the background of the mural.
- The artist will create the glass pieces that will be included in the mural.
- Glass pieces will be added to the wall.
- The lead artist will design the principal and secondary figures in the mural, until finished.
- Mural celebration. Community members and participants will be invited to small gathering, where the process and the product will be celebrated.

**Maintenance of the mural:** The wall will be prepared before painting the mural. Given the expertise of or team, best quality of materials will be used in the mural, which makes the work long lasting. After finishing, 2 layers of anti-graffiti protector will be added to the wall, which makes it easily cleanable in case of the mural being vandalized. Generally, walls that are painted with murals are rarely victims of vandalism. Still, the lead artists commits to three years of maintenance after the project is finished.

### Project Budget

Categories	Expenses
1. Project Leader (wall preparation, mural design, mural painting and finishing) Cristian Munoz	Honorary 2500
2. Assistant Coordinator (Dialogue sessions preparation, dialogue sessions facilitator, glass work creation, glass work addition to the mural, community painting organizer and promoter, community celebration organizer, preparing reports) Ximena Soza	Honorary 2500
3. Mural assistant (helps prepare the wall, helps painting the mural under lead artist's guidance)	Honorary 800
4. Painting supplies for project ( includes, primer, paint, brushes, anti-graffiti protection)	3350
5. glass supplies for project	850
<b>TOTAL PROJECT COSTS</b>	10,000

June 27,2018

**Letter of commitment for Cristian Munoz**

As an artist and resident of Albany, it would be a pleasure to be part of this project and accept the 2500 of honorariums that would be offered to me. By accepting this, I commit to complete the duties that would be assigned to me, which include : wall preparation, mural design, mural painting and finishing

Thank You so much,

Cristian Munoz

A handwritten signature in black ink, appearing to read 'Cristian Munoz', with a large, sweeping flourish underneath.

**June 27,2018**

**Letter of commitment for Ximena Soza**

As an artist and resident of Albany, it would be a pleasure to be part of this project and accept the 2500 of honorariums that would be offered to me. By accepting this, I commit to complete the duties that would be assigned to me, which include : Dialogue sessions preparation, dialogue sessions facilitator, glass work creation, glass work addition to the mural, community painting organizer and promoter, community celebration organizer, preparing reports.

Thank You so much,

Ximena Soza

## Cristian Muñoz 's Bio

Cristian Muñoz's artistic career started when he was still a teenager. During the years of the dictatorship of Augusto Pinochet in his native country Chile, Cristian supported the student movement and the political struggle of that time as a student and as an artist, working in Ramona Parra's muralist brigade and founding Brigada Renacer. His political murals are now part of several compilations on mural art in Chile and are part of private collections in Milwaukee and Chicago. During his years as an art student in Santiago, he participated in many collective exhibits and the creation of videos and documentaries that participated successfully in several short film festivals. One of his videos is in the collection of The Historical National Museum in Chile.

Since his arrival in the United States in 2007, he has participated in several collective exhibits in Milwaukee, Chicago, Berkeley, Oakland and San Francisco. He was also part of the two artist show Memories of the Forgotten in Milwaukee and Woven in Chicago, which soon will be shown at the Mission Cultural Center for the Latino Arts ( May, 2016) in San Francisco. Cristian has created several installations for Day of the Dead at The University of Wisconsin-Milwaukee, Walker's Point Center for the Arts, Latino Arts, The Milwaukee Art Museum and The Mission Cultural Center for Latino Arts. He also assisted UW- Milwaukee professor Raoul Deal in the multicultural exhibit Implosion at UWM and participated in the Watershed project.

As a muralist, working in the Bay Area, Cristian has committed his artistic work to the creation of backdrops for performances at La Peña Cultural Center and The Serpent of the Four Seasons at the University of San Francisco's Theater department. He worked as a muralist assistant in the Song of Unity mural in downtown Berkeley, and in multiple mural projects in Oakland, Berkeley and Albany. He has taught muralism to youth in different projects in Richmond. His latest murals can be seen in the Olhone Bike Path.

Web site

KILIMUNOZ.WIX.COM/ARTANDMURALISM

Ximena Soza Vergara, Ph.D.  
1051 Castro St.#4 Albany, CA 94706  
Cell: (510) 982-9124  
ximenasozav@gmail.com

## EDUCATION

### **Doctor of Philosophy in Urban Education, Advanced Opportunity Program Fellow**

(2013) University of Wisconsin-Milwaukee

Specialization: Social Foundations in Education

Dissertation Title: Teacher and Staff Perceptions of the Implementation of an Antiracist and Dual Language Bilingual Program at an Urban School

Thesis Directors: Rene Antrop-Gonzalez and Raji Swaminathan

### **Master of Science in Education**

(2009) University of Wisconsin-Milwaukee

Specialization: Cultural Foundations of Education

### **Postgraduate Certification in Bicultural Education**

(2005) *Universidad Arcis Patagonia* (Castro, Chile)

### **Bachelor of Education (*Honors Graduate*)**

(2005) *Universidad Academia de Humanismo Cristiano* (Santiago, Chile)

Specialization: Elementary School Teacher

Honors-in-the-Major Thesis Title: *Educación Intercultural Bilingüe en una Escuela Williche de la Isla de Chiloe* (Intercultural/Bilingual Education in a Williche School of Chiloe)

### **Mapudungun** (Mapuche's language)

(2004) DIBAM, Santiago, Chile

## LANGUAGE SKILLS

Fully bilingual English and Spanish (native speaker)

Advanced Portuguese

advanced Italian

Intermediate Mapudungun (Mapuche language)

## PROFESSIONAL EXPERIENCES

Debunking Stereotypes Through Muralism (Mural project and dialogs of stereotypes and social justice)  
Project design, project coordinator and workshop facilitator. (Richmond California)

Art Teacher to adults with mental illness

Design curriculum, manage art budget, taught art classes and prepare exhibits of the participant's work

**Casa Ubuntu, Bonita House** (Oakland, California)

November 2016- present

Spanish Teacher

Ximena Soza Vergara, Ph.D.  
1051 Castro St.#4 Albany, CA 94706  
Cell: (510) 982-9124  
ximenasozav@gmail.com

Designs and implements curriculum for Spanish language and Latin American Culture to children grades K5 to 6th.

**Walden Community Schools** (Berkeley, California)

September 2016-present

Spanish Teacher

Designs and implements curriculum for Spanish language and Latin American Culture to adults.

**Centro Latino** (Berkeley, California)

June 2016-present

Art Teacher to adults with mental illness

Design curriculum, manage art budget, taught art classes and prepare exhibits of the participant's work

**Institute of Public Health**, (Oakland, California)

July 2014- January 2016

Art Teacher

Design curriculum and taught art to children ages 2-12

**University of California-Berkeley Recreation Department** (Albany, California)

July 2013-December 2015

Guest Professor Didactics of Language and Literature Department

Taught antiracist education's principles and practical applications to future educators and social workers

**Universidad de Granada** (Granada, Spain)

September 2011- June 2012

Bilingual First Grade Teacher

Designed and implemented an antiracist curriculum using both, English and Spanish.

**La Escuela Fratney** (Milwaukee, Wisconsin)

June 2005- June 2011

Co-owner and Director Summer Art Camps

Co-directed, designed and coordinated all activities related to the art camps, such as budget, meals, and fieldtrips and art classes.

**Community Art Camp at Riverwest/ Riverwest Artists Association** (Milwaukee, Wisconsin)

June 2008- August 2010

Actor, Theater of the Oppressed Workshops Facilitator

Worked as a facilitator and participant of Theater of the Oppressed workshops with diverse communities to address issues of social justice

**The Milwaukee Public Theater (in collaboration with The Latino Health Organization) The Medical College of Wisconsin** (Milwaukee, Wisconsin)

June 2005-June 2008

Actor, Theater of the Oppressed Workshops Facilitator

Worked as a facilitator and participant of Theater of the Oppressed workshops with diverse communities to address issues of social justice

**Teatro Maquis** (Milwaukee, Wisconsin)



Ximena Soza Vergara, Ph.D.  
1051 Castro St.#4 Albany, CA 94706  
Cell: (510) 982-9124  
ximenasozav@gmail.com

September 2006-June 2008

Summer Art Program Coordinator

Coordinated the art program including the budget, the staff and programming for the center

**Walker's Point Center for the Arts (Milwaukee, Wisconsin)**

Summer 2006

Bicultural Rural Teacher

Designed and implemented an intercultural curriculum to first and second grade using Spanish and some Mapudungun (local indigenous language).

**Escuela José Santos Lincoman (Chiloe, Chile)**

June 2004-June 2005

Bicultural Rural Teacher, Professional Practice

Designed and implemented an intercultural curriculum to first, second and third grade using Spanish and some Mapudungun (local indigenous language).

**Escuela Kume Ruka (Chiloe, Chile)**

March 2004-June 2004

ESL Teacher

Designed and implemented ESL curriculum to students in different health science careers

**Universidad Nacional Andrés Bello (Santiago, Chile)**

March 2000-December 2003

Youth Art Program Director

Directed a multidisciplinary art program; designed the curriculum, managed the budget, which included supplies, meals and salaries. Hired and managed the staff and volunteers, did outreach and programming.

**Mental Health Center, COSAM (Santiago, Chile)**

May 2000-December 2003

Multicultural Summer Arts Program Coordinator

Designed and implemented the curriculum, managed the budget and coordinated artists, special events, and exhibits.

**Greater Lawn Youth Community Network (Chicago, Illinois)**

May-September 1997

Art Instructor

Designed and implemented art curriculum for youth ages 5 to 17

**Boys and Girls Clubs of Chicago, Lathrop Club (Chicago-Illinois)**

March 1996-March 1997

Owner and Administrator

Designed, created and sold silver jewelry

**Antv Jewelry Store (La Serena-Chile)**

May 1994-February 1996

Participant, Southern Route Assistant Coordinator

Coordinated visits to indigenous communities and organizations throughout Peru, Ecuador, Colombia, Panamá, Costa Rica, Honduras, El Salvador, Guatemala, México

**Peace and Dignity Journeys**

Ximena Soza Vergara, Ph.D.  
1051 Castro St.#4 Albany, CA 94706  
Cell: (510) 982-9124  
ximenasozav@gmail.com

September 2006-June 2008

Summer Art Program Coordinator

Coordinated the art program including the budget, the staff and programming for the center  
**Walker's Point Center for the Arts (Milwaukee, Wisconsin)**  
Summer 2006

Bicultural Rural Teacher

Designed and implemented an intercultural curriculum to first and second grade using Spanish and some Mapudungun (local indigenous language).

**Escuela José Santos Lincoman (Chiloe, Chile)**

June 2004-June 2005

Bicultural Rural Teacher, Professional Practice

Designed and implemented an intercultural curriculum to first, second and third grade using Spanish and some Mapudungun (local indigenous language).

**Escuela Kume Ruka (Chiloe, Chile)**

March 2004-June 2004

ESL Teacher

Designed and implemented ESL curriculum to students in different health science careers

**Universidad Nacional Andrés Bello (Santiago, Chile)**

March 2000-December 2003

Youth Art Program Director

Directed a multidisciplinary art program; designed the curriculum, managed the budget, which included supplies, meals and salaries. Hired and managed the staff and volunteers, did outreach and programming.

**Mental Health Center, COSAM (Santiago, Chile)**

May 2000-December 2003

Multicultural Summer Arts Program Coordinator

Designed and implemented the curriculum, managed the budget and coordinated artists, special events, and exhibits.

**Greater Lawn Youth Community Network (Chicago, Illinois)**

May-September 1997

Art Instructor

Designed and implemented art curriculum for youth ages 5 to 17

**Boys and Girls Clubs of Chicago, Lathrop Club (Chicago-Illinois)**

March 1996-March 1997

Owner and Administrator

Designed, created and sold silver jewelry

**Antv Jewelry Store (La Serena-Chile)**

May 1994-February 1996

Participant, Southern Route Assistant Coordinator

Coordinated visits to indigenous communities and organizations throughout Peru, Ecuador, Colombia, Panamá, Costa Rica, Honduras, El Salvador, Guatemala, México

**Peace and Dignity Journeys**

Ximena Soza Vergara, Ph.D.  
1051 Castro St.#4 Albany, CA 94706  
Cell: (510) 982-9124  
ximenasozav@gmail.com

March-October 1992

**PRIZES, FELLOWSHIPS GRANTS AND SCHOLARSHIPS:**

City of Richmond Art Mini Grants (Richmond 2017-2018)

Graduate School Travel Award, UW-Milwaukee (2013)

AOP Fellowship, UW-Milwaukee (2009-2012)

Robert Kuehneisen and Eiserlo Scholarship Fund, Milwaukee-Wisconsin (2010-2011)

Education Department Scholarship, UW-Milwaukee (2009-2010)

Department of Caribbean and Latin American Studies Travel Award, UW-Milwaukee (2010)

Graduate School Travel Award, UW-Milwaukee (2010)

National Scholarship for Indigenous Studies CONADI, Chiloe, Chile (2004-2005)

National Scholarship for Students in Teaching Careers, Ministerio de Educación, Santiago, Chile (2000-2005)

1<sup>st</sup> place Short Stories, Familias y Terapias, Santiago, Chile (2003)

3<sup>rd</sup> place Short Stories, Un Puente en el Arte, Cordoba, Argentina (2003)

1<sup>st</sup> place Short Stories Anthology ENE Espacio, USA (2004)

**CONFERENCES AND PRESENTATIONS**

**Mapudunguun Basico Bari, Italy (2018)**

Mapuche Language

**Sotto le Suole, Bari, Italy (2018)**

Stories of Displacement

**Diversos, Con Con, Chile (2018)**

Racism and antiracist strategies

**Racismo en Chile, Movimiento Autonomo, Santiago, Chile (2018)**

Racism and antiracist strategies

**Mapudunguun Basico UC Berkeley, Berkeley, California (2018)**

Mapuche Language

Ximena Soza Vergara, Ph.D.  
1051 Castro St.#4 Albany, CA 94706  
Cell: (510) 982-9124  
ximenasozav@gmail.com

**Instituto Black Bom, Rio de Janeiro (2017)**  
Immigration and Stories of Displacement

**Universidad de Veracruz, Poza Rica (2013)**  
Immigration and Stories of Displacement

**Universidad Huasteca Intercultural, Ixhatlán de Madero, Veracruz, México (2013)**  
Immigration and Stories of Displacement

**Dalton State College, Dalton, Georgia (2013)**  
Day of the Dead

**Dalton State College, Dalton, Georgia (2013)**  
Latinas/os in Dalton

**Facultad de Melilla Universidad de Granada, Melilla, España (2012)**  
Educación Antirracista

**Ciclo de Conferencias, Instituto Ilibiris, Atarfe, España (2012)**  
Más que tolerancia

**Programa de inclusión, Universidad de Granada, Granada, España (2012)**  
Más que tolerancia

**Conferencia de Humanidades, Universidad de Granada, Granada, España (2011)**  
Educación Antirracista en el primer Ciclo Básico,

**School of Education Research Conference, UW-Milwaukee (2011)**  
Social Justice in Early Childhood Education

**Universidad Católica de Valparaiso, Viña del Mar, Chile (2011)**  
Teachers and Antiracist Education

**XVI Congreso Mundial de Ciencias de la Educación, Monterrey- México, (2010)**  
Educación Antirracista en el primer Ciclo Básico

**School of the Education research conference, UW-Milwaukee, Milwaukee-Wisconsin, (2010)**  
Social Justice Curricula in Early Childhood

**Multicultural association conference, UW-Milwaukee, Milwaukee-Wisconsin, (2010)**  
Antiracist Versus Multicultural Education

**Advance Language and Academic Studies, Milwaukee-Wisconsin, (2009)**  
Chilean Student Movement

**Borders Forum UW-Oshkosh, Oshkosh-Wisconsin, 2008**  
Borders in Latin America

**Department of Caribbean and Latin American Studies, UW-Milwaukee, Milwaukee- Wisconsin, (2008)**

Ximena Soza Vergara, Ph.D.  
1051 Castro St.#4 Albany, CA 94706  
Cell: (510) 982-9124  
ximenasozav@gmail.com

Chile; Yesterday and Today

## EXHIBITS

**Una Canzone per il Popolo Mapuche, Bari, Italy, 2018**  
Bajo las Suelas/ Underneath the Soles (Solo Public Exhibit)

**La Notte Bianca di la Poesia, Giovinatzo, Italy, 2018**  
Bajo las Suelas/ Underneath the Soles (Solo Public Exhibit)

**Verona, Italy, 2018**  
Bajo las Suelas/ Underneath the Soles (Solo Public Exhibit)

**La Casa Loca, Milan, Italy, 2018**  
Bajo las Suelas/ Underneath the Soles (Solo Public Exhibit)

**Imola, Bologna, Italy, 2018**  
Bajo las Suelas/ Underneath the Soles (Solo Public Exhibit)

**Hearst Museum of Anthropology, UC- Berkeley, Berkeley, CA, 2018**  
Dreaming the Wallmapu, curator and artist.

**Cien Puertas, Guatemala, Guatemala, 2017**  
Bajo las Suelas/ Underneath the Soles (Solo Public Exhibit)

**Instituto Black Bom, Rio de Janeiro, Brazil, 2017**  
Bajo las Suelas/ Underneath the Soles (Solo Public Exhibit)

**Plaza de los Immigrantes, Santiago, Chile, 2017**  
Bajo las Suelas/ Underneath the Soles (Solo Public Exhibit)

**La Pena Cultural Center, Berkeley, CA 2017**  
Bajo las Suelas/ Underneath the Soles (Solo Public Exhibit)

**Latino Arts, Milwaukee, WI 2016**  
Broken Dreams (Solo artist show)

**Mission Cultural Center for Latino Arts, May 2016**  
Tejidos/ Woven (Two artists show)

**Mission Cultural Center, San Francisco-California, 2016**  
*30th Solo Mujeres*

**Mission Cultural Center, San Francisco-California, 2015**  
Intersectionality (Curator and participant)

Ximena Soza Vergara, Ph.D.  
1051 Castro St.#4 Albany, CA 94706  
Cell: (510) 982-9124  
ximenasozav@gmail.com

**La Peña Cultural Center, Berkeley-California, 2015**  
*40th Aniversary (Collective Exhibit)*

**Museum of Oakland California, Oakland-California, 2014**  
*Songs and Sorrows (Collective Exhibit)*

**University of Minnesota, Minnesota, 2014**  
*Ni de Aquí, Ni de Allá, (Collaborating Poet to Raoul Deal's Prints)*

**Mission Cultural Center, San Francisco-California, 2014**  
*Day of the Dead Annual Exhibit (Collective Exhibit)*

**Latino Arts, Milwaukee-Wisconsin, 2014**  
*Day of the Dead Annual Exhibit (Collective Exhibit)*

**La Peña Cultural Center, Berkeley-California, 2014**  
*Tejidos (Two artist exhibit in Collaboration with Cristian Muñoz)*

**Mission Cultural Center, San Francisco-California, 2014**  
*Home Inside Out (Collective Exhibit)*

**Escuela de Las Americas Watch, Oakland-California, 2014**  
*Heridas (Curator and Participant, Collective Exhibit)*

**Universidad de Veracruz, Poza Rica, Veracruz-Mexico, 2013**  
*Bajo las Suelas (Solo Public Exhibit)*

**Universidad Huasteca Intercultural, Ixhatlan de Madero, Veracruz- Mexico, 2013**  
*Bajo las Suelas (Solo Public Exhibit)*

**Dalton State College, Dalton-Georgia, 2013**  
*Day Of the Dead (Solo Exhibit)*

**MAGI Cultural Art Center, Chicago-Illinois, 2013**  
*Woven (Two artist exhibit in Collaboration with Cristian Muñoz)*

**La Mission's MAPP, San Francisco-California, 2013**  
*De Arcos y de Portones (Solo Public Exhibit)*

**Headquarters, Berkeley-California, 2013**  
*Rupture (Collective Exhibit)*

**Albany Public Library, Albany- California, 2013**  
*Handle with Care (Solo Exhibit)*

Ximena Soza Vergara, Ph.D.  
1051 Castro St.#4 Albany, CA 94706  
Cell: (510) 982-9124  
ximenasozav@gmail.com

**El Jardín Secreto, San Francisco-California, 2013**  
Colectivo (Solo Exhibit)

**La Peña Cultural Center, Berkeley-California, 2013**  
*Las Almas no Desaparecen* Souls don't Disappear, 40 Years Commemoration of the Chilean Coup (Collective Exhibit)

**MAGI Cultural Art Center, Chicago-Illinois, 2013**  
*Bajo las Suelas* (Solo Public Exhibit)

**People's Bookstore, Milwaukee-Wisconsin, 2013**  
*Bajo las Suelas* (Solo Public Exhibit)

**San Francisco's Mission's District MAPP, San Francisco-California, 2013**  
*Bajo las Suelas* (Solo Public Exhibit)

**Latino Arts, Milwaukee-Wisconsin, 2013**  
*Ni de Aquí, Ni de Allá*, (Collaborating Poet to Raoul Deal's Prints)

**Red Poppy Art House, San Francisco-California, 2012**  
*De la raíz y su desarraigo* (Two artists Exhibit)

**Latino Arts, Milwaukee-Wisconsin, 2005-2013**  
Day of the death *Ofrendas* (Collective Exhibits)

**Walker's Point Center for the Arts, Milwaukee-Wisconsin, 2005-2011**  
Day of the death *Ofrendas* (Collective Exhibits)

**Latino Arts, Milwaukee-Wisconsin, 2011**  
Tasting Cultures: The Arts of Latino Food ways (Collective Exhibit)

**UW-Milwaukee Milwaukee-Wisconsin, 2010**  
Watershed Project in collaboration (In Collaboration with Cristian Muñoz)

**UW-Whitewaters, Whitewaters-Wisconsin, 2010**  
A New America: A Bilingual Society (Four Artists Show)

**Riverwest Artist Association, Milwaukee-Wisconsin, 2010**  
Illuminate (Collective Exhibit)

**Riverwest Artist Association, Milwaukee-Wisconsin, 2009**  
Memories of the Forgotten (Two artist exhibit in Collaboration with Cristian Muñoz)

**Allen Priebe Art Gallery, UW-Oshkosh, Oshkosh-Wisconsin, 2008**  
Border (Four Artists Show)

Ximena Soza Vergara, Ph.D.  
1051 Castro St.#4 Albany, CA 94706  
Cell: (510) 982-9124  
ximenasozav@gmail.com

**Walker's Point Center for the Arts, Milwaukee-Wisconsin, 2008**  
*Latinos Emergentes* (Curator and Participant, Collective Exhibit)

**Union gallery UW-Milwaukee, Milwaukee-Wisconsin 2006- 2008**  
Day of the death *Ofrendas* (Collective Exhibit)

**Ministerio de Educaciòn, Santiago-Chile, 2001**  
Escuela de Escultores (Collective Exhibit)

**Galería Fundacion, Santiago-Chile, 2000**  
Escuela de Escultores (Collective Exhibit)

## **PERFORMANCES**

**La Notte Bianca di La Poesia, Giovinatzo, Italy, 2018**  
Poetry

**La Peña Cultural Center, Homenaje to Violeta Parra, Berkeley-California, 2017**  
Poetry

**La Peña Cultural Center, Berkeley-California, 2016**  
Poetry

**Mission Cultural Center, San Francisco-California, 2013**  
Poetry

**Red Poppy Art House, San Francisco-California, 2013**  
Poetry and monologues, various presentations

**La Peña Cultural Center, Berkeley-California, 2013**  
Poetry and monologues, various presentations

**MAGI Cultural Art Center, Chicago-Illinois, 2013**  
Poetry

**The Secret Garden, San Francisco-California, 2012**  
Poetry

**Red Poppy Art House, San Francisco-California, 2012**  
Poetry and monologues, various presentations

**University of Wisconsin-Milwaukee, Milwaukee-Wisconsin, 2011-2009-2008**  
*Latina Monologues*, writing and performance,

**Milwaukee Institute of Art and Design, Milwaukee-Wisconsin, 2009**



Ximena Soza Vergara, Ph.D.  
1051 Castro St.#4 Albany, CA 94706  
Cell: (510) 982-9124  
ximenasozav@gmail.com

9-9-09 showcase multimedia performance

**Teatro Maquis, Milwaukee-Wisconsin 2005-2009**

Multiple theater of the oppressed presentations

**University of Wisconsin, Milwaukee-Wisconsin, 2007**

Our Voice, Our Story

**Latino Arts inc. Milwaukee-Wisconsin, 2005**

*El Dia Que Me Quieras*

## **PUBLICATIONS**

**La Machina Sognante, 2018**

Interview, Sotto le Suole

**The Dreaming Machine, 2018**

Underneath the Soles

**The Dreaming Machine, 2018**

Hijo

**La Machina Sognante, Italia, 2017**

Visistando San Cristobal

**HEDS: Educational Studies, 2015**

*Social Justice within a School in Granada Practices on Gender, Race, and Environment*

**Berkeley Public Library, Estados Unidos, 2014**

*Hijo, a Short Memoir*

**Publicaciones Facultad de Educación y Humanidades Campus Melilla, Universidad de Granada, 2012**

*Antiracist Education: Education that Fights Racism Inside and Outside School*

**Antología de Poesía y Cuento, Un Puente en el Arte, Cordoba- Argentina 2003**

*El Retrato de mi Madre*

**Antología de Cuentos Cortos, ENE Espacio, USA 2004**

*La Guillermina*

**Revista Instituto Chileno de Terapia Familiar, Santiago Chile, 2004**

*El Retrato de mi Madre*

## **INTERNATIONAL RESEARCH/TEACHING TRAVELS**

Ximena Soza Vergara, Ph.D.  
1051 Castro St.#4 Albany, CA 94706  
Cell: (510) 982-9124  
[ximenasozav@gmail.com](mailto:ximenasozav@gmail.com)

Chile, Mexico, Spain, Brazil, Guatemala, Italy

## REFERENCES

Raoul Deal  
Senior Lecturer  
Department of Visual Art , Peck School of the Arts  
Artist-in-Residence Cultures and Communities Program  
University of Wisconsin-Milwaukee  
PO Box 413  
Milwaukee, WI 53201-0413  
[rgdeal@uwm.edu](mailto:rgdeal@uwm.edu)  
Phone: 414 229-1154

Laura Trafi-Prats, Ph.D.  
Associate Professor  
Art Education Area Head  
Department of Art and Design  
Peck School of the Arts  
University of Wisconsin-Milwaukee  
PO Box 413, Milwaukee, WI 53201-0413  
[trafipra@uwm.edu](mailto:trafipra@uwm.edu)  
Phone: 414 690-8963

Anne Richards  
Co-Director Culture of Inclusion Project  
Researcher  
Public Health Institute  
555 12<sup>th</sup> street  
Oakland, California, 94607  
[tannerichards@aol.com](mailto:tannerichards@aol.com)  
Phone: 510-204-9700



MURAL WALL.









HCC / Kilimürz. ulk.cem/arcandirualism









ALBANY Middle school

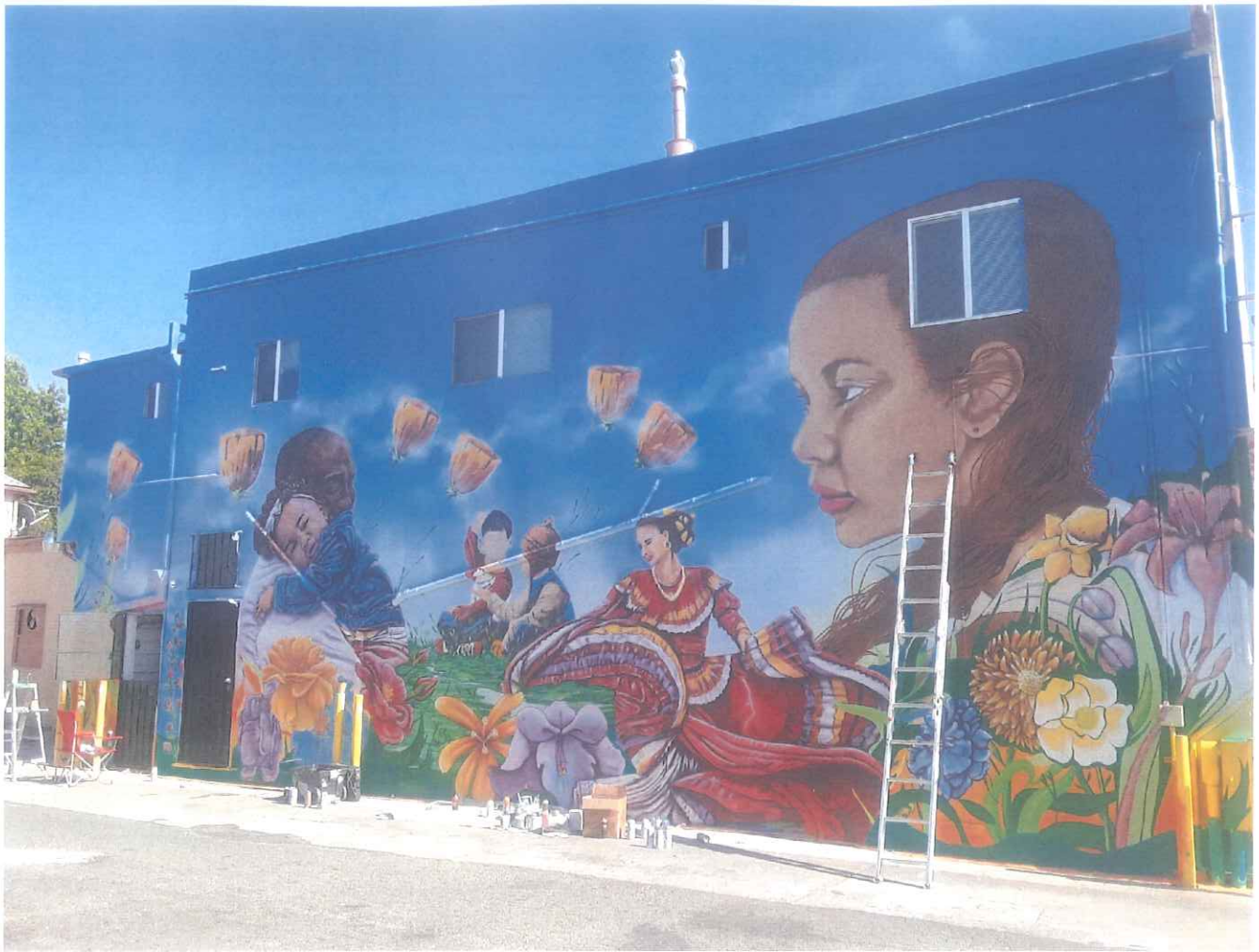

DeBUNKING stereotypes  
RICHMOND.



SAN PABLO 1212  
Berkeley