

MULTIFAMILY

GREEN BUILDING GUIDELINES



GREEN BUILDING

*Alameda County Waste Management Authority
Alameda County Source Reduction and Recycling Board*

CONTENTS

PREFACE iv

INTRODUCTION 1

PLANNING & DESIGN

 Introduction Section 1, Page 1

 Planning & Design Measure 01 – Measure 15 5 – 40

SITework

 Introduction Section 2, Page 1

 Sitework Measure 01 – Measure 04 5 – 11

STRUCTURE

 Introduction Section 3, Page 1

 Structure Measure 01 – Measure 13 5 – 31

SYSTEMS

 Introduction Section 4, Page 1

 Systems Measure 01 – Measure 19 5 – 43

FINISHES & FURNISHINGS

 Introduction Section 5, Page 1

 Finishes & Furnishings Measure 01 – Measure 10 7 – 25

OPERATIONS & MAINTENANCE

 Introduction Section 6, Page 1

 Operations & Maintenance Measure 01 – Measure 02 5 – 8

CASE STUDIES Section 7

RESOURCES Section 8

ALAMEDA COUNTY WASTE MANAGEMENT AUTHORITY & SOURCE REDUCTION AND RECYCLING BOARD

The Alameda County Waste Management Authority (ACWMA) is a public joint-powers agency comprised of the County of Alameda, each of the fourteen cities within the county, and two sanitary districts that also provide refuse collection services. ACWMA is governed by a Board of Directors made up of elected officials, primarily mayors and city council members, appointed by each member agency. Funding is derived solely from waste disposal and waste import mitigation fees collected at the Altamont, Tri-Cities and Vasco Road landfill sites. The agency receives no general tax funds.

Together with its specialized arm—the Alameda County Source Reduction and Recycling Board—ACWMA offers a wide range of programs in the areas of public education, green building, recycled product procurement, waste reduction, market development and technical assistance.

ACKNOWLEDGEMENTS

Special thanks to the following building industry professionals for their commitment, input and direction in developing these Guidelines.

DEVELOPMENT COMMITTEE

Carolyn Bookhart and Marie Lee, *Allied Housing* ■ Helen Degenhardt and Susan Vutz, *JSW/Degenhardt Architecture* ■ Carl Gardeman and Michael Noon, *Alameda County Housing and Community Development* ■ Kevin Griffin, *Bridge Housing* ■ Larry Mayers, *Michael Willis Architects* ■ Lee Novak, *AF Evans Development* ■ Fred Pollack, *Van Meter Williams Pollack Architecture* ■ Robert Rich, *San Francisco Office of Housing* ■ Michael Rogers, *Resources for Community Development* ■ Eric Saijo, *Okamoto Saijo Architecture* ■ Doug Shoemaker, *Non-Profit Housing Association*

ADDITIONAL REVIEWERS & CONTRIBUTORS

David Choy ■ Sean Heron, *East Bay Housing Organizations* ■ Marty Keller, Jeff Oberdorfer, and Betsy Powell, *First Community Housing* ■ Dennis Kim and Kirk Wallis, *Segue Construction* ■ Marc Richmond, *Austin Energy* ■ Taylor Robinson and Ross Schaefer, *Cahill Construction* ■ Andrea Traber, *Andrea Traber Architecture* ■ California Integrated Waste Management Board staff and Sustainable Building Technical Group members

PILOT PROJECTS AND PROJECT DEVELOPMENT TEAMS

Carmen Avenue: Milly Siebel, *City of Livermore* ■ Marie Lee and Carolyn Bookhart, *Allied Housing* ■ Steven Kodama and Lulit Taka, *Kodama Diseno*
Bayport Apartments: Debbie Potter, *City of Alameda* ■ Michael Rogers and Brian Saliman, *Resources for Community Development* ■ Helen Degenhardt and Susan Vutz, *JSW/Degenhardt Architects*
Dublin Senior Affordable Housing: Julia Abdala, *City of Dublin* ■ Linda Mandolini and Marian Gushiken, *Eden Housing* ■ Chris Lamén, *Chris Lamén and Associates*

Special thanks to Global Green for allowing the reprinting of their case studies.

DISCLAIMER

The information in these Guidelines should be considered by contractors, architects and other professionals, as well as owners, in the course of designing and constructing new or modified structures. They are provided as a public service by the Alameda County Waste Management Authority and Recycling Board in an attempt to provide environmental benefits and reduce costs. The Guidelines are not a substitute for exercise of sound judgment in particular circumstances and are not intended as recommendations for particular products or processes.

PROJECT TEAM

The Alameda County Waste Management Authority & Source Reduction and Recycling Board

777 Davis Street, Suite 100
San Leandro, CA 94577
510.614.1699
www.multifamilygreen.org
Contact: Karen Kho and Ann Ludwig

KEMA-Xenergy

429 Ninth Street, Suite 220
Oakland, CA 94607
510.891.0446
www.kemagreen.com
Contact: Geof Syphers and Wes Sullens

What's Working

57 Acorn Lane
Boulder, CO 80304
313.444.7044
Contact: David Johnston
www.whatsworking.com

Jennifer Roberts, Freelance writer & editor

San Francisco, CA
www.jenniferroberts.com
415.695.1721

DESIGN & PRODUCTION

Celery Design Collaborative, Design & illustration
www.celerydesign.com

The **cover** of these Guidelines is printed on 100% recycled chipboard. The **binding** uses copper-coated 100% recycled steel wire. The **divider pages** are printed on Fraser Genesis, 100% postconsumer recycled paper. The divider tabs are specially designed to eliminate die-cutting waste. The **measures and case studies** are printed on Neenah Environment PC100 White, 100% postconsumer recycled paper.

For more information on these and other environmentally smart papers, see Celery's Ecological Guide to Paper at www.celerydesign.com/paper.

ABOUT THE GUIDELINES

These Guidelines are designed for the multifamily residential building industry. They offer:

- » Cost-effective suggestions to minimize construction-related waste, create healthier and more durable residences, reduce operating costs for owners and support local manufacturers and suppliers of resource-efficient building materials.
- » Methods to reduce the impacts of building in Alameda County communities, including infill development, energy efficiency, indoor air quality, solid waste management, water conservation and resource conservation.

The practices contained in these Guidelines were selected for their viability in today's market and their ability to promote sustainable building. For-profit developers using these Guidelines can differentiate themselves in the marketplace while protecting our environment. Affordable housing providers can lower their operating costs while improving the quality of life for residents.

In November 2002, ACWMA asked Alameda County and cities in Alameda County to nominate projects in their communities to take part in a design assistance program for affordable multifamily housing projects. Three pilot projects were chosen to receive technical assistance in exchange for participating in the development of these Multifamily Green Building Guidelines. A development committee of multifamily developers and architects helped define the audience and purpose of the guidelines and, along with other reviewers, provided feedback on the technical content.

AGENCY INVOLVEMENT

Construction and demolition debris comprise up to 21% of the materials disposed in Alameda County landfills. The Alameda County Waste Management Authority and Recycling Board is working in partnership with the construction and building industry on ways to reduce this waste stream. Through job site recycling, efficient use of materials, use of recycled content or highly durable building materials, the Multifamily Green Building Guidelines provide an effective tool to decrease the amount of material that ends up in landfills.

CONSTRUCTION WASTE GENERATED FROM A 2,000 SQUARE FOOT NEW HOME

The chart below illustrates the composition and quantity of waste generated during the construction of a typical single-family home. Multifamily building projects differ in size, materials, and construction methods, but they have comparable impacts on the waste stream.

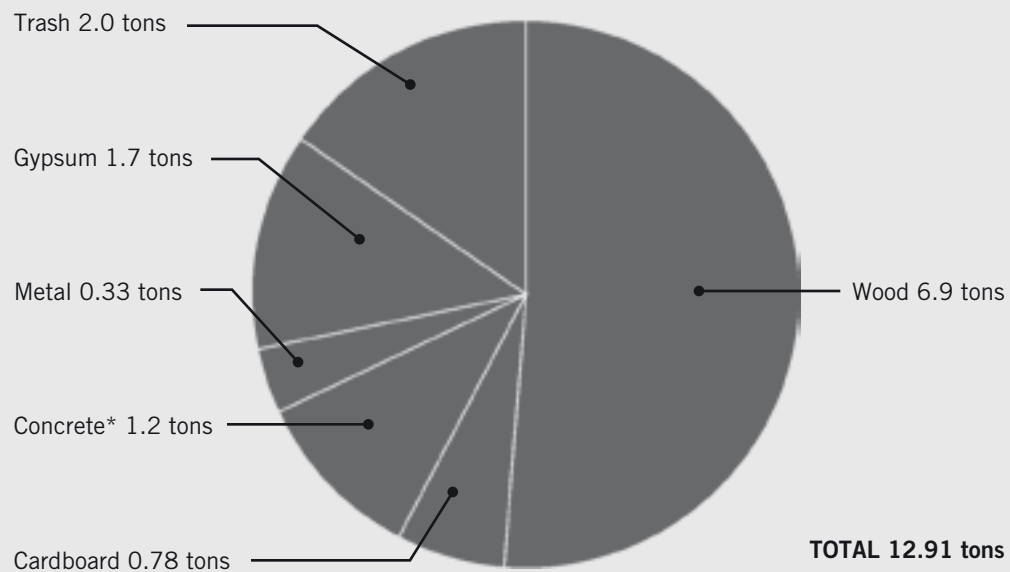

Source: Alameda County Waste Management Authority Case Study of Citation Homes (1999).

*Concrete figure includes waste generated by sidewalk pour.

MULTIFAMILY GREEN BUILDINGS: THE BIG PICTURE

Does green really matter?



Common rooms, such as this building at Murphy Ranch in San Jose, are an integral part of multifamily living.

Creating green multifamily housing isn't about altruism. It isn't about doing good or feeling groovy. And it isn't about adding a few bells and whistles to a proposal so that it will pass muster with funders, community leaders or building officials.

Green building is about improving our design and construction practices so that the multifamily homes we build today will last longer, cost less to operate, and won't harm the health of workers and residents. It is also about protecting natural resources and improving the built environment so that ecosystems, people, enterprises and communities can thrive and prosper.

Green building represents a paradigm shift—a crucial change in the way we understand, design and build housing in today's world. It doesn't happen by accident—it requires thorough planning, thoughtful design and quality construction. With the budget and time pressures we're all under today, is it really worth the extra effort?

We think it is. Green housing is good for people, good for Bay Area communities, and good for the natural environment. Better buildings, it turns out, are also better for business. Developers, designers and other building professionals who follow “building as usual” practices may find themselves at a competitive disadvantage as regulatory and market forces shift the industry toward built environments that are healthier, more resource efficient and less polluting.

Who should use these Guidelines?



Multifamily green buildings can blend harmoniously with contemporary design. The Nueva Vista project in Santa Cruz creates inviting spaces—inside and out.

ACWMA's Multifamily Green Building Guidelines were developed to bring technical expertise to Alameda County developers, architects, builders and building managers. The Guidelines are the result of collaboration among developers, architects, builders, building officials, green building experts, and staff of the Alameda County Waste Management Authority and Recycling Board. The expertise of these diverse stakeholders is reflected through a focus on practices and approaches that are most relevant to affordable and market-rate multifamily housing in Alameda County.

The measures in these Guidelines range from basic, commonsense recommendations such as designing entryways so that fewer contaminants are tracked in on people's shoes, to installing sophisticated renewable energy generation systems on site. No matter where you are on the green building spectrum—from novice to expert—you will find resources, design ideas, product information, case studies and real-world advice that you can put to use today.

If you or your organization has not yet embraced green building, these Multifamily Green Building Guidelines—as well as many other resources offered by ACWMA—will provide you with a solid foundation for getting started. You will find many of the measures to be quite easy to incorporate into projects immediately. Other measures that require more effort can be added to your practice as you gain experience and build support for green design within your organization.

If you are experienced with developing high-quality multifamily housing, some of the approaches and products recommended here may already be part of your daily practice. In that case, these Guidelines will help you employ more advanced green-building strategies that will reinforce your organization's leadership position.

These Guidelines can be used in different ways depending on your role in the multifamily housing development process. Here are some considerations:

- » **Policymakers.** Read the introduction to each section for an overview of green building for multifamily housing. Then read through the measures in the Planning & Design section. These are particularly relevant because they include policy recommendations you can adopt before a project is even proposed.
- » **Developers.** Use these Guidelines as a way to organize your team's approach to green building; the Guidelines will help provide your team with a common language for discussing alternative design. Reference the Guidelines in your RFQs and RFPs for architects, and use it as a discussion guide throughout design. The table on page 7 provides a useful timeline for when to focus on particular design strategies. Property managers should read the Operations & Maintenance section carefully for ideas on minimizing operating costs.
- » **Architects.** Treat these Guidelines as both an idea book and a reference manual. When beginning a new project, scan the list of measures in the Green Building Timetable on page 6 for ideas that might be appropriate for your project. Within each measure, use the graphic guides and the Description and Benefits information to help spark the creative process. Although there are many more strategies for promoting healthy, efficient and ecological construction than are covered by these Guidelines, we have included enough material to provide a solid starting point.

Once the project is underway, use this as a reference book. The technical advice in each measure's Design Details, along with the Resources, should significantly reduce the time you need to spend evaluating materials, equipment and strategies.

Be sure to visit www.multifamilygreen.org to access the green building Materials Database of manufacturers and suppliers for many green products and materials. Check the website periodically for the latest version, since the list changes frequently.

- » **Contractors.** Use the Guidelines to familiarize yourself with general green building strategies and as a reference manual to reduce the time you spend on researching product availability and cost. Start by reading the full write-up for each measure used in your project. When estimating costs, reread the Costs section in each measure. Use the additional resource list at www.multifamilygreen.org to find products and suppliers.

What is green building?

Green building is a whole-systems approach to the design, construction and operation of buildings—from the early stages of development through the final finishes. This approach benefits building industry professionals, residents and communities by improving construction quality, increasing building longevity, reducing utility and maintenance costs, and enhancing comfort and livability.

There's nothing mysterious about green building—it's really just applied commonsense. To move forward with greening your construction project, it is helpful to think of green building as the convergence of three fundamental objectives:

1. Conserve natural resources
2. Increase energy efficiency
3. Improve indoor air quality

NATURAL RESOURCES CONSERVATION

Conventional building construction and operation needlessly consume large quantities of wood, water, metal, fuel and other natural resources. Wood, for example, is one of the most common building materials, but it is often used wastefully. Fortunately, advanced framing techniques have been developed that can substantially reduce lumber requirements. And using engineered lumber and wood products certified by the Forest Stewardship Council can help protect old-growth forests. In fact, there are a great variety of effective building strategies that conserve natural resources, as well as providing benefits such as cost savings. One approach is to avoid using unnecessary materials, such as by allowing structural elements like concrete floors to serve as finish materials. Other strategies include using durable products to reduce waste and specifying recycled-content products that reuse natural resources.

ENERGY EFFICIENCY

Energy efficiency is the cornerstone of any green building project. Improving energy efficiency and using renewable energy sources are effective ways to reduce the potential of energy supply interruptions, improve air quality and reduce the impacts of global warming. Improving energy efficiency also makes economic sense for building owners and residents: an energy-efficient building saves money by reducing utility bills year after year.

INDOOR AIR QUALITY

Poor indoor air quality is often caused by mold and mildew that build up as a result of moisture infiltration or poorly designed and maintained heating and cooling systems. Dust, another major source of indoor air pollution, can be reduced by using track-off floor mats at entryways, and by using easily cleanable flooring materials such as natural linoleum, wood or wood alternatives, or concrete. Another common source of indoor air pollution is the offgassing of chemicals found in many building materials. Pressed-wood products such as particleboard and plywood paneling, for example, are typically held together by adhesives that release formaldehyde—a probable human carcinogen—into the home for years after installation. Many paints, floor finishes, adhesives and sealants also emit unhealthy volatile organic compounds (VOCs). Fortunately, the building products industry is responding to these indoor air pollution problems by developing safer products, including alternative glues in pressed-wood products, and low-VOC paint, finish and adhesive products.

Role of integrated design in green building

Too often, design and building disciplines remain highly fragmented: developers and funders select (or are given) a site; architects design the building; mechanical and electrical engineers design HVAC and lighting; and so on. It is rare, for instance, to involve the mechanical engineer in architectural decisions, even though those decisions might significantly affect equipment costs and energy use.

To minimize the cost and maximize the benefits of green building, use an integrated design process that involves people who represent these perspectives:

- » Owner
- » Occupant (may be represented by an experienced property manager)
- » Architect
- » Mechanical/electrical/plumbing engineers
- » Civil engineer/landscape architect
- » Builder/contractor
- » Maintenance/operations personnel

Integrated design aims to connect as many members of a project team as possible. Introduce integration early. Hold meetings early with all the major stakeholders. Tour the site. Discuss green strategies early on and use them to identify the level of green desired for this particular project.

Set clear goals from the beginning. Whatever the goals are—reducing first costs, for example, or providing healthy interiors—every team member must be aware of the goals and committed to achieving them.

Integrating the design process allows for creative solutions to complex problems. Questions can be raised and answered openly through a charrette or team meeting. New technologies or practices are explored as a group, allowing enthusiasm, skepticism and solutions to surface at the same time. Misconceptions can be cleared up, and changes to standard practice can be highlighted as a learning experience.

It's no coincidence that buildings designed this way are better buildings. Strategies like passive solar heating take time and care to design, but can significantly reduce heating needs, improve comfort, and, except in extreme cases, eliminate the need for air conditioning.

How integrated design can reduce costs

While the health and environmental benefits of green building are well established, many people still assume that green building costs more. But taking an integrated approach to design can actually reduce construction and operating costs. At a certain critical point, it's possible to achieve significant cost savings compared to standard practice if integrated design is used. A contractor, for example, can be engaged early in design to help steer the design away from expensive solutions and toward cost-effective ones. The options available during schematic design can easily include strategies such as simplifying a building's wall structure by changing the wall articulation to a flat wall with bolted-on overhangs and thick trim. Such a change can often save money and a lot of wood, but would be costly to do once construction documents were underway.

Just as the contractor can help the design team find cost-effective green solutions, so can the other team members. The mechanical engineer may be able to recommend increasing the exterior wall thickness to accommodate more insulation, which could result in reducing the size and cost of the heating system. If the developer is concerned with achieving HUD noise ratings and is part of this conversation, she may ask the engineer whether using special sound-rated windows will also help reduce cooling needs.

These collaborative discussions are powerful, but the range of cost-effective solutions narrows as the design progresses. Consider daylighting, for example. During schematic design, daylighting can be achieved by moving the glazing to the north and south walls and correspondingly adjusting the interior spaces. The cost of this change is close to zero. If daylighting goals aren't raised until the design development phase, it may be possible to provide daylighting by changing the heights of windows and the depth of roof eaves, for a moderate cost increase. But if daylighting goals aren't raised until the construction document phase, daylighting might have to be achieved by selecting high-end glazing and installing light shelves, for a considerable cost increase.

For every recommendation in these Guidelines, we have carefully weighed the measure's cost against its benefits to justify its inclusion. While not all measures will be applicable to your project, we feel that the measures included are relevant and reasonable for multifamily developments built today.

Some of the recommended measures do cost more initially, but this additional cost needs to be evaluated in the context of the longer-term benefits provided: utility cost savings, better indoor air quality for residents, healthier jobsites for workers, and longer building life. When considering green building measures, it is very important to balance upfront design, product and construction costs with these other significant benefits (this process of evaluating the long-term costs of design decisions is often referred to as "lifecycle cost analysis").

Funding affordable housing involves unique challenges and opportunities, particularly if the design includes green building measures that may cost more upfront but provide long-term benefits. For good information about funding affordable, green multifamily buildings in the San Francisco Bay Area, refer to *The Materials Handbook: Guidelines for Affordable Sustainable Housing*, published by the San Francisco Mayor's Office of Housing and Asian Neighborhood Design (available from www.andnet.org).

Green building can be seen as pushing the design and construction industry to do things that may be new, such as integrating the design process. New practices sometimes cost money. But green buildings are more than just buildings. They are the end result of a collaboration between people on all levels of design and construction who are committed to improving on yesterday's practices.

Taking incremental steps toward building green

Green design comes in many shades. Many projects are "light green": they include a handful of fairly conventional but effective strategies, such as energy-efficient lighting or high-efficiency heating. Other projects are "medium green"— they've taken bigger strides toward including high-performance attributes such as advanced framing or cool roofs. And then there are cutting-edge green projects that fully embrace integrated design and may even have advanced features such as building-integrated photovoltaics.

If you aren't able to take an integrated approach to design on your current project, you can still take steps toward creating a healthier and more energy- and resource-efficient building. Inside these Guidelines you'll find many strategies that are easy to implement and add virtually no cost, such as low-VOC paints, sealants and adhesives, recycled-content carpet, and water-efficient fixtures. Your project may not be labeled "green," but you can still include many of these simpler measures. As your team's experience with green building grows, you'll likely find yourselves scaling up to ever healthier and more effective design and construction practices.

Green building timetable

The table below allows you to quickly scan all the measures in these Guidelines to get a feel for when each measure becomes a priority during the development process. During the initial community planning phase, for example, critical decisions arise such as whether to choose an infill site or develop the project for mixed uses. But other measures, such as specifying high-performance windows or ENERGY STAR® appliances, can be decided later, during design development. Use this table as a general tool for planning purposes, and refer to it as your projects progress.

| | DEVELOPMENT PHASE | COMMUNITY PLANNING | SITE PLANNING | CONCEPTUAL DESIGN | DESIGN DEVELOPMENT | CONSTRUCTION DOCUMENTS | CONSTRUCTION | POST-CONSTRUCTION & OCCUPANCY |
|--|-------------------|--------------------|---------------|-------------------|--------------------|------------------------|--------------|-------------------------------|
| PLANNING & DESIGN | | | | | | | | |
| 01 Infill sites | ✓ | | | | | | | |
| 02 Mixed-use developments | ✓ | | | | | | | |
| 03 Building placement and orientation | | | ✓ | | | | | |
| 04 Design for walking and bicycling | ✓ | ✓ | | | | | | |
| 05 Social gathering places | ✓ | ✓ | | ✓ | | | | |
| 06 Design for safety | ✓ | ✓ | | | | | | |
| 07 Vandalism deterrence & management | | | | ✓ | | | | ✓ |
| 08 Landscaping | ✓ | ✓ | | ✓ | | ✓ | ✓ | ✓ |
| 09 Cool site | | ✓ | | ✓ | | | | |
| 10 Stormwater management | | ✓ | | | | | | |
| 11 ENERGY STAR®—certified homes | | | ✓ | | | | | |
| 12 Moisture shedding & mold avoidance | | | | ✓ | | | | |
| 13 Recycling collection | | | | ✓ | | | | |
| 14 Recycled products | | | | ✓ | | | | ✓ |
| 15 Adaptable buildings | | ✓ | ✓ | | | | | |
| SITework | | | | | | | | |
| 01 C&D waste management | | | | ✓ | ✓ | | | |
| 02 Efficient use of construction materials | | | | | ✓ | ✓ | | |
| 03 Construction IAQ management | | | | | ✓ | | | |
| 04 Hazardous materials & waste | | | | | ✓ | ✓ | | |

STRUCTURE

| | DEVELOPMENT PHASE | COMMUNITY PLANNING | SITE PLANNING | CONCEPTUAL DESIGN | DESIGN DEVELOPMENT | CONSTRUCTION DOCUMENTS | CONSTRUCTION | POST-CONSTRUCTION & OCCUPANCY |
|-----------------------------------|-------------------|--------------------|---------------|-------------------|--------------------|------------------------|--------------|-------------------------------|
| 01 Recycled aggregate | | | | | ✓ | | | |
| 02 High-volume flyash in concrete | | | | ✓ | | | | |
| 03 FSC-certified wood | | | | | ✓ | | | |
| 04 Engineered lumber | | | | ✓ | | | | |
| 05 Advanced framing design | | | | ✓ | | | | |
| 06 Steel framing | | | | ✓ | | | | |
| 07 Structural insulated panels | | | | ✓ | | | | |
| 08 Raised heel trusses | | | | | ✓ | | | |
| 09 Insulation | | | | | ✓ | | | |
| 10 Durable siding materials | | | | ✓ | | | | |
| 11 Durable roofing options | | | | ✓ | | | | |
| 12 Cool roof | | | | ✓ | | | | |
| 13 High-performance windows | | | | ✓ | | | | |

SYSTEMS

| | | | | | | | | |
|---|--|---|---|---|---|--|--|--|
| 01 Passive solar heating | | ✓ | ✓ | | | | | |
| 02 Thermal mass flooring | | ✓ | ✓ | | | | | |
| 03 High-efficiency heating | | | ✓ | ✓ | | | | |
| 04 Radiant hydronic space heating | | | ✓ | ✓ | | | | |
| 05 Solar water heating | | ✓ | ✓ | | | | | |
| 06 High-efficiency water heating | | | | ✓ | | | | |
| 07 Avoid air conditioning | | ✓ | ✓ | | | | | |
| 08 High-efficiency AC with advanced refrigerant | | | | ✓ | | | | |
| 09 Duct effectiveness | | | | | ✓ | | | |
| 10 Advanced ventilation practices | | | | ✓ | | | | |
| 11 Garage ventilation | | | | ✓ | ✓ | | | |
| 12 Daylighting | | ✓ | ✓ | | | | | |
| 13 High-efficiency lighting | | | | ✓ | | | | |

(SYSTEMS, continued)

| | DEVELOPMENT PHASE | COMMUNITY PLANNING | SITE PLANNING | CONCEPTUAL DESIGN | DESIGN DEVELOPMENT | CONSTRUCTION DOCUMENTS | CONSTRUCTION | POST-CONSTRUCTION & OCCUPANCY |
|----------------------------------|-------------------|--------------------|---------------|-------------------|--------------------|------------------------|--------------|-------------------------------|
| 14 Light pollution reduction | | | ✓ | ✓ | | | | |
| 15 Onsite electricity generation | ✓ | ✓ | ✓ | | | | | |
| 16 Elevators | | | | ✓ | | | | |
| 17 ENERGY STAR® appliances | | | | ✓ | | | | |
| 18 Central laundry | | | ✓ | | | | | |
| 19 Water-efficient fixtures | | | | ✓ | | | | |

FINISHES & FURNISHINGS

| | | | | | | | | |
|--|--|--|--|---|---|--|--|---|
| 01 Entryways | | | | | ✓ | | | |
| 02 Interior paint | | | | | ✓ | | | |
| 03 Adhesives and sealants | | | | | ✓ | | | |
| 04 Metal coatings | | | | | ✓ | | | |
| 05 Carpeting | | | | | ✓ | | | |
| 06 Natural linoleum | | | | | ✓ | | | |
| 07 Wood flooring alternatives | | | | | ✓ | | | |
| 08 Reclaimed materials | | | | | ✓ | | | |
| 09 Cabinets, counters & trim | | | | | ✓ | | | |
| 10 Furniture and outdoor play structures | | | | ✓ | | | | ✓ |

OPERATIONS & MAINTENANCE

| | | | | | | | | |
|--------------------------------|--|--|--|--|---|---|---|--|
| 01 Training and manuals | | | | | ✓ | ✓ | ✓ | |
| 02 Educational signage & tours | | | | | | ✓ | ✓ | |

Inside the Guidelines

The ACWMA Multifamily Green Building Guidelines consist of more than 60 recommended measures grouped into six sections. Each section begins with an overview that provides context for the measures within that section. The sections are briefly described here:

Planning & Design. Includes recommendations on site selection, building orientation, mixed-use development, site design that promotes social interaction and physical activity, landscaping strategies, stormwater management, building adaptability and recycling.

Sitework. Includes recommendations on managing the construction process to minimize disruption to the site, protect worker health, use construction materials efficiently and reduce waste.

Structure. Addresses the building's structure and envelope, including concrete, framing, roofing and siding materials, insulation and windows.

Systems. Covers five categories of building systems: heating, ventilation and air conditioning; daylighting and electric lighting; appliances; onsite energy generation; and plumbing fixtures and systems.

Finishes & Furnishings. Addresses healthy, environmentally preferable finishes and furnishings, including adhesives, sealants, paints and metal coatings; flooring options including entryway design, carpet, linoleum and alternatives to wood flooring; reclaimed materials; cabinets, counters and trim; and furniture.

Operations & Maintenance. Covers O&M practices including maintenance manuals and training for residents and building staff, and educational signage and tours.

GREEN BUILDING MEASURES

While separating green building strategies into individual measures may give the impression that they can be used in isolation, in reality each measure is closely integrated with many other design strategies. To encourage teams to work across disciplines and embrace an integrated design approach, each measure contains many cross-references to related measures. For example, the Daylighting measure (Systems: Measure 12) refers to Planning & Design: Measure 03—Building Placement and Orientation.

The individual measures are presented with a consistent layout so you can scan them for relevant information. Each measure begins with an “at-a-glance” graphic, as shown in the example below.

Measure number — **MEASURE 04**

Measure title — **DESIGN FOR WALKING AND BICYCLING**

Summary of recommendation — **Design Developments for Safe, Pleasant Walking and Bicycling**

People who need to pay particular attention to this measure —

| WHO | KEY BENEFITS |
|---|---|
| <ul style="list-style-type: none"> ✓ Developer/PM • Funder ✓ Policymaker ✓ Architect ✓ Builder Resident Building Manager | <ul style="list-style-type: none"> ✓ Health/IEQ • Site/Community Energy Efficiency Water Efficiency Material Efficiency ✓ O&M ✓ Resident Satisfaction ENERGY STAR |

Construction Specification Institute's (CSI) Division or Specification number — **02870: Site and Street Furnishings**

This measure's principal benefits:

- Health/IEQ:** Reduces indoor pollutants, promotes better indoor environmental quality, and/or provides opportunities for improved public health.
- Site/Community:** Protects land, water and air on and near site from pollution or other environmental damage, uses municipal infrastructure more efficiently by redeveloping building or site, and/or provides important and needed amenities for the surrounding community.
- Energy Efficiency:** Reduces building energy consumption.
- Water Efficiency:** Reduces water use in building and/or on site.
- Material Efficiency:** Reduces, reuses and/or recycles materials that might have otherwise ended up in landfills, reduces materials needed to construct or operate the building, and/or uses materials produced in a way that minimizes environmental damage.
- O&M:** Increases building's durability, and/or reduces operating and maintenance expenses.
- Resident Satisfaction:** Saves residents money, and/or improves residents' quality of life.
- ENERGY STAR®:** Helps achieve ENERGY STAR® for Homes certification.

Following the “at-a-glance” graphic, each measure includes the following information:

Recommendation. A brief statement summarizing the recommended action or actions.

Description. An overview of the relevant design and construction issues, providing context for the Recommendation.

Benefits. Summary of the range of possible benefits the measure offers, including cost savings for developers, owners and residents; waste reduction; energy and resource conservation; community benefits; environmental protection; indoor air quality improvements; and much more.

Application. Types of projects where the Recommendation is most relevant.

Design Details. Special design and construction details to consider when implementing the Recommendation.

Code Considerations. Relevant local, state or federal code issues that may apply, above and beyond standard code considerations.

Considerations for Residents. Effect of the measure on residents, including benefits and special information the residents should know.

Cost and Cost Effectiveness. In some cases, specific cost information is provided. In other cases, relative costs or lifecycle cost information is given.

| | |
|---------|-----------|
| BENEFIT | ★★★ |
| COST | \$ \$\$\$ |

The symbols ★ and \$ are used as rough indicators of each measure’s relative benefits and costs. ★ or \$ equals low benefit or cost, ★★ or \$\$ equals medium benefit or cost, and ★★★ or \$\$\$ equals high benefit or cost. The cost reflects the anticipated increase over standard practice. These actual costs may vary considerably among projects and will depend on availability of materials.

Resources. Additional websites, agencies, industry organizations or publications to consult for more information about this particular green building strategy *(for specific products and materials, see below)*.

GREEN BUILDING MATERIALS DATABASE

ACWMA maintains an online database of green building products and materials available locally and suitable for multifamily buildings. The database, which is searchable by product category, product name and measure number, is available at www.multifamilygreen.org.

UPDATES TO THE GUIDELINES

ACWMA intends to update these Guidelines periodically to ensure that they reflect the latest and best practices. For information or to offer suggestions for updates, please visit www.multifamilygreen.org, or call (510) 614-1699 and ask for Karen Kho or Ann Ludwig.

PLANNING & DESIGN

The measures in this section encompass fundamental planning and design decisions that, for the most part, need to be made very early in the development process. The choices made at this stage, such as site selection and building orientation, will have a profound effect on the project's success from an environmental, economic and social perspective.

Many of the recommendations in this section address ways in which a development can help strengthen a community's economy and improve quality of life for all its citizens.



BENEFITS

This table lists the Guidelines' Planning & Design measures, and shows the primary benefits of each. Many of the measures in this section provide broad-based social and environmental benefits that go well beyond improving an individual building's performance. For example, people who live in mixed-use developments (*Planning & Design: Measure 02*) rather than conventional suburban developments are more likely to get physical exercise by walking to nearby shops and neighborhood services.

| MEASURE | BENEFITS | | | | | | | | |
|---------------------------------------|------------|----------------|-------------------|------------------|---------------------|-----|-----------------------|--------------|--|
| | Health/IEQ | Site/Community | Energy Efficiency | Water Efficiency | Material Efficiency | O&M | Resident Satisfaction | ENERGY STAR® | |
| 01 Infill sites | ✓ | ✓ | | | ✓ | | ✓ | | |
| 02 Mixed-use developments | ✓ | ✓ | | | ✓ | | ✓ | | |
| 03 Building placement & orientation | | ✓ | ✓ | ✓ | | ✓ | ✓ | | |
| 04 Design for walking & bicycling | ✓ | ✓ | | | | ✓ | ✓ | | |
| 05 Social gathering places | ✓ | ✓ | | | | ✓ | ✓ | | |
| 06 Design for safety | ✓ | | | | | ✓ | ✓ | | |
| 07 Vandalism deterrence & management | ✓ | ✓ | | | | ✓ | ✓ | | |
| 08 Landscaping | | ✓ | ✓ | ✓ | ✓ | ✓ | ✓ | | |
| 09 Cool site | | ✓ | ✓ | | ✓ | | ✓ | | |
| 10 Stormwater management | | ✓ | | ✓ | | ✓ | | | |
| 11 ENERGY STAR®-certified homes | ✓ | | ✓ | | ✓ | ✓ | ✓ | ✓ | |
| 12 Moisture shedding & mold avoidance | ✓ | | | | | ✓ | ✓ | | |
| 13 Recycling collection | | | | | ✓ | ✓ | ✓ | | |
| 14 Recycled products | | | | | ✓ | | | | |
| 15 Adaptable buildings | ✓ | ✓ | | | ✓ | ✓ | ✓ | | |

| EXPLANATION OF BENEFITS |
|---|
| <p>Health/IEQ: Reduces indoor pollutants, promotes better indoor environmental quality, and/or provides opportunities for improved public health.</p> <p>Site/Community: Protects land, water and air on and near site from pollution or other environmental damage, uses municipal infrastructure more efficiently by redeveloping building or site, and/or provides important and needed amenities for the surrounding community.</p> <p>Energy Efficiency: Reduces building energy consumption.</p> <p>Water Efficiency: Reduces water use in building and/or on site.</p> <p>Material Efficiency: Reduces, reuses and/or recycles materials that might have otherwise ended up in landfills, reduces materials needed to construct or operate the building, and/or uses materials produced in a way that minimizes environmental damage.</p> <p>O&M: Increases building's durability, and/or reduces operating and maintenance expenses.</p> <p>Resident Satisfaction: Saves residents money and/or improves residents' quality of life.</p> <p>ENERGY STAR®: Helps achieve ENERGY STAR® for Homes certification.</p> |

KEY CONSIDERATIONS

CONNECTIONS TO THE NATURAL AND BUILT ENVIRONMENT

Fundamental to green design is the relationship between a building and the environment—both the natural and the built environment. While affordable housing projects typically have more site constraints than market-rate housing, every site presents unique opportunities. The design team should carefully assess the site's natural elements—including solar access, wind conditions and existing plant and animal life—and strive to design in harmony with those elements to reduce energy use, increase livability and protect the environment.

Planning and design decisions related to the built environment—existing buildings, streets, commercial development, parks, schools and more—are as important as the decisions related to the natural environment. To assess how to best take advantage of the surroundings, the project team may need to do considerable analysis and develop a number of schematic designs.

INTEGRATED DESIGN

For a project to make a significant difference in terms of economic and environmental sustainability, as well as quality of life for building residents and the community at large, it's best to take an integrated approach to design.

The recommended Planning & Design measures presented here are fundamental to integrated design, and should be addressed with as much care, time and resources as the project can bear. Choices made at this stage may affect hundreds of decisions later on. For example, if a choice is made—either actively or by default—to not maximize a building's orientation for best solar access, that may preclude many green design strategies, from passive solar heating to daylighting to eliminating air conditioning (*for more about integrated design, see the Guidelines' introduction*).

COMMUNITY SUPPORT

An important aspect of green multifamily housing is creating conditions that foster economic and social well-being in the community. Many of the measures in this section offer tremendous community benefits, ranging from reduced traffic congestion to more attractive opportunities for recreation to greater economic vitality. For the developer, engaging municipal representatives and community leaders early in the design process can pave the way to a much more successful project.

CODE ISSUES

In some municipalities, density, zoning and other code issues may sometimes conflict with green design strategies, such as infill and mixed-use developments, improved pedestrian and bicyclist access, and even certain environmentally friendly landscaping practices. Early in the planning process, the development team should identify potentially problematic code issues and work with the appropriate officials to overcome these barriers.



Good planning considers the needs of people and the environment. This multifamily development includes rooftop photovoltaic panels on a community building next to a playground.

ROLES AND RESPONSIBILITIES

COST

For local municipalities, the measures in this section can provide many economic benefits. Developments designed to reduce dependence on cars help ease traffic congestion, which can improve business productivity. Mixed-use developments encourage economic vitality and a diversified municipal tax base. Infill projects help revitalize older urban areas.

For the developer, some of the recommended Planning & Design measures can be done with little or no extra cost if incorporated early. Providing recycling collection facilities, for example, costs very little and can potentially reduce waste disposal fees for years to come. Other measures—such as choosing infill sites and creating mixed-use developments—may require additional design time. But cost increases can often be offset or minimized by adopting an integrated design approach (*see the introduction to these Guidelines*).

- » **Policy maker and code official.** Facilitate infill development. Support community planning processes that lead to local area plans or master plans. Support zoning codes that promote appropriate mixed-use developments. Adopt strategies that promote walking and bicycling. Promote and support environmentally sound landscaping practices.
- » **Developer and project manager** (*also see Builder below*). Start early on winning community support. Identify potential code barriers early and work with local officials to overcome them.
- » **Architect, engineer, landscape architect and interior designer.** Work as a team and embrace an integrated design process. Find design solutions that bridge the gaps between the needs of various stakeholders. Learn from existing projects—exemplary and otherwise.
- » **Builder** (*also see Developer above*). Include the builder early in the design phase to facilitate acceptance of new ideas or practices. Builders don't traditionally have a major role in planning and design, but it's usually more effective to involve the builder early as an integral member of the planning team.
- » **Building manager.** Encourage existing and new tenants to promote recycling. Keep the building and its grounds well tended to discourage crime and vandalism. Follow the recommended landscaping O&M practices. Follow green practices and use green products in maintenance, cleaning, repainting, repairing and remodeling activities.

FOCUS ON PLANNING & DESIGN:
Carmen Avenue

Allied Housing's 30-unit community in downtown Livermore, to be built in 2004–2005, was designed green from the start. The buildings are oriented on an east-west axis for passive solar heating and cooling, which will reduce energy consumption while providing comfortable homes. The buildings frame a courtyard that provides attractive outdoor space, and the contractor plans to preserve a large mature tree in the courtyard area. Parking was positioned to the rear of the site so that the homes connect with the community.

To learn more about this project, see the Carmen Avenue case study.

INFILL SITES

Develop Existing Urban Sites Rather Than Greenfields

| WHO | KEY BENEFITS |
|--------------------------|-------------------------|
| ✓ Developer/PM Funder | ✓ Health/IEQ |
| ✓ Policymaker | ✓ Site/Community |
| Architect | ✓ Energy Efficiency |
| Builder | ✓ Water Efficiency |
| Resident | ✓ Material Efficiency |
| Building Manager | O&M |
| | ✓ Resident Satisfaction |
| | ENERGY STAR® |

Recommendation

Develop existing urbanized sites (“infill”) rather than open space and farmland (“greenfields”). Where possible, redevelop existing buildings.

Description

Infill development reduces pressure to develop greenfields by reclaiming abandoned and underutilized sites and buildings.

Most new development in the San Francisco Bay Area is taking place on the region’s eastern fringe. Residents of these outlying areas depend on cars because pedestrian, bicycle and public-transit travel is usually impractical. This pattern of low-density and car-based development, called suburban sprawl, has been linked to a host of environmental and social problems, including:

- » Air pollution from vehicles
- » Loss of business and individual productivity from traffic congestion
- » Inefficient use of public infrastructure
- » Reduced physical activity
- » Less time for family and community

Market demand for infill development is increasing. The Urban Land Institute’s 2004 survey of real estate investors showed general skepticism about the market, but support for infill:

“The few exceptions: 1) for-sale housing in infill locations, which scored high interest due to downtown migration by singles and empty nesters, as well as tighter growth controls in outlying areas; 2) low- and moderate-income apartments in close-in areas to help fill the need for

affordable housing; 3) brownfield restoration, now considered less risky than in the past, and which offers good prospects for town center housing; and 4) master-planned communities with open space and pedestrian-friendly design.”

Benefits

Urban infill allows public funds to be used for upgrading existing services such as sewers, schools and transit, rather than diverting those limited funds to the development of new services.

Projects that restore blighted or polluted sites (“brownfields”) have the double benefit of avoiding greenfield development and improving quality of life in existing communities. Redevelopment projects can preserve an area’s historic character while promoting economic revitalization.

Reusing existing buildings minimizes waste and reduces the need for new construction material.

Application

Affordable housing developments are more constrained in their site selection than market-rate projects. They are commonly located on infill sites.

When selecting a development site, give preference to locations with these characteristics:

- » Downtown area
- » Targeted for revitalization
- » Proximity to major employment centers
- » Reuse of parking lots, vacant lots, abandoned buildings, former industrial sites or historic sites
- » Within an urban growth boundary or designated for development by the local jurisdiction

Find locations where good transit service already exists (typically, no more than one-quarter to one-half-mile from the site), or where there is a high likelihood for future service improvement, such as an historic town center or redevelopment district.



Consult remediation experts if you are considering a site that has been contaminated. It may be best to avoid excavating a site and leave contaminated soil in place. Some contaminated sites will be inappropriate for residential use if it is cost-prohibitive to bring them up to acceptable standards.

Design Details

Integrate the building and its site with the existing neighborhood. Multifamily buildings, even if they are high density, should echo or complement the neighborhood's existing development patterns. Avoid a bulky or monotonous appearance by breaking down the scale of large building volumes.

Identify ways to facilitate social interaction, such as creating pocket parks, plazas or mixed-use developments (*Planning & Design: Measure 02—Mixed-Use Developments / Planning & Design: Measure 05—Social Gathering Places*).

Reduce onsite parking and minimize the visual impact of parking structures (*for strategies to deal with parking, see Planning & Design: Measure 04—Design for Walking and Bicycling*). If mature vegetation exists or is planned for the site, design underground garages so they will not interfere with root systems.



Mandela Gateway Plaza—an infill development adjacent to the West Oakland BART station.

Code Considerations

Policymakers can facilitate infill development by designating appropriate sites for development, and permitting higher-density development in target areas. Parking ratios can be reduced at transit-friendly sites. Support community planning processes that lead to local area plans or master plans. These processes help a neighborhood articulate its vision for development and can lead to a less contentious public review process for specific development proposals. Neighborhood plans reduce uncertainty for the developer when they identify desired community facilities and development types.

Considerations for Residents

People living in infill developments are more likely to shop, work and play close to home. They will have more transportation options and opportunities for social interaction.

Cost and Cost Effectiveness

| | | |
|---------|--------|--|
| BENEFIT | ★★★ | Infill projects require additional design time, because high-quality design is critical to gaining community acceptance. Brownfield sites can have very high cleanup costs, but some municipalities may be willing to incur these expenses in order to encourage development of neglected areas. |
| COST | \$\$\$ | |

Municipalities pay more to provide services to suburban development than to infill development. According to a recent study by the Natural Resources Defense Council:

“Sprawl, the predominant pattern of land development in the last half-century, is fiscally inefficient because it can increase the costs of operating and maintaining utility services. .. If local governments can significantly reduce O&M costs by growing smarter, they can increase levels of public services and/or reduce costs, thereby reducing financial burdens and increasing the quality of life for their citizens.”

Resources

- » **Local Government Commission publications:** “Design Guidelines for Multifamily Housing”: www.lgc.org/freepub/land_use/guidelines/multifamily_housing.html; and “A Policymaker’s Guide to Infill Development”: www.lgc.org/bookstore/land_use/publications/infilldvlpmnt.html
- » **Urban Land Institute:** www.uli.org
- » **Northeast-Midwest Institute’s** “Strategies for Successful Infill Development”: www.nemw.org/infillbook.htm
- » **California Center for Land Recycling’s** resources on brownfield redevelopment: www.cclr.org
- » **Bank of America**—sponsored paper: “Beyond Sprawl: New Patterns of Growth to Fit the New California”: www.rut.com/misc/beyondSprawl.html

MIXED-USE DEVELOPMENTS

Incorporate Nonresidential Uses in Multifamily Housing Developments

| WHO | KEY BENEFITS |
|---|--|
| <ul style="list-style-type: none"> ✓ Developer/PM ✓ Funder ✓ Policymaker ✓ Architect ✓ Builder ✓ Resident ✓ Building Manager | <ul style="list-style-type: none"> ✓ Health/IEQ ✓ Site/Community Energy Efficiency Water Efficiency ✓ Material Efficiency O&M ✓ Resident Satisfaction ENERGY STAR® |

Recommendation

Provide shopping, employment, social or community facilities within a multifamily housing development.

Description

Mixed-use developments combine more than one use (for example, residential, retail, office) in a single building or development area. This type of development was prevalent until the early twentieth century, when municipalities adopted zoning codes that segregated residential from commercial and industrial uses. Single-purpose zoning is environmentally unsustainable because it creates dependence on automobiles and uses land inefficiently. Some experts also believe it has contributed to a decline in civic engagement.

Demographic, economic and environmental factors are driving market demand for developments where people can work, shop, play and meet their daily needs close to where they live. Also, the shrinking supply of available undeveloped land is fostering new interest in urban redevelopment.

Benefits

Mixed-use developments:

- » Create a sense of place and provide more opportunities for social interaction
- » Increase neighborhood economic vitality
- » Strengthen and diversify the municipal tax base
- » Increase transportation options such as walking, biking and public transit, and reduce vehicle trips

- » Use land, public infrastructure (roads, water, sewer, etc.), and facilities more efficiently
- » Reduce regional imbalances between jobs and housing

Application

Multifamily housing projects can successfully incorporate nonresidential uses, except on the most severely constrained sites. An integrated design approach is critical to the success of any mixed-use development (for more about integrated design, see the introduction to these Guidelines).

Design Details

IDENTIFY COMMUNITY NEEDS

Engage municipal representatives and community leaders early in the design process. Providing amenities that are desired by the community will increase local support for the project.

Identify services and facilities that are currently lacking in the community and determine whether it is economically feasible to incorporate any of them into the project. Commonly desired amenities include grocery stores and childcare facilities. Design the project so that neighbors can also use plazas, meeting rooms or other facilities.

ADDITIONAL STRATEGIES FOR MARKET-RATE HOUSING

Market-rate developers may also consider these strategies for successful mixed-use projects:

- » Conduct market research to identify the appropriate size and type of retail and what segment of the housing market to target.
- » Bring legal expertise to the building team to address building leasing, governance issues, ownership agreements and zoning requirements.
- » Consider developing larger projects in phases to make financing easier to attract.



Residential units located above ground-floor commercial spaces in the Fruitvale Transit Village in Oakland.

CREATING A SENSE OF PLACE

Locate retail uses on the ground floor to create visual interest and clear destinations for pedestrians. Design building facades that are aesthetically varied and stimulating, with windows that provide a connection between the interior and exterior. Corner buildings should overlook both street frontages and create a sense of place. Consider placing benches, tables and planters outside the building to create a favorable environment for social interaction and retail activity *(for additional design strategies that support walking and bicycling, social gathering and safety, see Planning & Design: Measure 04 / Planning & Design: Measure 05 / Planning & Design: Measure 06)*.

STRUCTURAL CONSIDERATIONS



Mixed-use buildings present special structural challenges because code and user requirements differ for each type of use.

Structural considerations include:

- » Location of entries and exits
- » Stacking of structural columns
- » Placement of heating and ventilation shafts and mechanical and plumbing systems
- » Building security and access controls
- » Fire protection systems and escape routes
- » Noise screening

Code Considerations

Code requirements for residential, office, retail and parking uses differ and may be incompatible. Some local jurisdictions and planning authorities have regulations that prohibit or restrict mixed-use development. Design teams should identify code problems early and work with local officials to resolve them.

Policymakers can promote mixed-use development by removing special variances, providing zoning flexibility, assisting in financing, and assembling property development rights.

Considerations for Residents

Residents of mixed-use buildings are more likely to shop, work and play close to home. They have more opportunities for social interaction and leisure time, and may have increased transportation options.

Cost and Cost Effectiveness

| | | |
|---------|--------|---|
| BENEFIT | ★★★ | May cost more due to increased structural complexity. Cost increases can be minimized by adopting an integrated design approach <i>(see the case study in these Guidelines)</i> . |
| COST | \$\$\$ | |

Mixed-use developments may be more complicated to finance because lenders are accustomed to single- and separate-use financing economics and policies. However, market forces and environmental factors are increasingly supporting this kind of development.

Resources

- » **Urban Land Institute** has many books and online resources on mixed-use development: www.uli.org
- » **Bay Area Local Initiatives Support Corporation (LISC)** provides resources on mixed-use development: www.cdexchange.org/commercial
- » **Seattle's Daily Journal of Commerce** published a helpful article on structural considerations, "Mixed Use and Maximum Value": www.djc.com/news/ae/11139451.html
- » **Southern California Association of Governments** has useful publications, including "Facilitating Small-Scale Mixed-Use Development: What the Westside Cities Could Do": www.scag.ca.gov/livable



Parking spaces are shared by residential and commercial users at the mixed-use Cotati Co-Housing development.

BUILDING PLACEMENT AND ORIENTATION

Consider Ecology, Energy and Circulation Patterns When Orienting Buildings

| WHO | KEY BENEFITS |
|--|--|
| <ul style="list-style-type: none"> ✓ Developer/PM Funder Policy maker ✓ Architect ✓ Builder ✓ Resident ✓ Building Manager | <ul style="list-style-type: none"> Health/IEQ ✓ Site/Community ✓ Energy Efficiency ✓ Water Efficiency Material Efficiency ✓ O&M ✓ Resident Satisfaction ENERGY STAR® |

Recommendation

Place the building to minimize disruption and fit into the surrounding landscape.

Analyze the site in terms of vegetation, wildlife habitat, surrounding buildings, land contours and climatic conditions.

Orient the building or buildings to take advantage of solar access and prevailing winds.

Promote car-free transit by focusing on circulation patterns, connecting walkways and paths.

Description

On a given site, often there are many options for placing and orienting buildings. Effectively locating a building involves three goals:

1. Protect or restore the local environment,
2. Maximize free energy, and
3. Provide efficient and safe circulation patterns for occupants.

A site's physical characteristics and location combine to create a unique microclimate. On undeveloped sites, there may be existing vegetation, wetlands, landforms, contours and other natural elements that influence building placement. There may be ways to protect or restore wildlife habitats, improve stormwater management or preserve existing trees.

In urban areas the considerations are different from greenfields. In cities, shade and noise from adjoining streets can affect solar gain and occupant comfort. Neighboring buildings, parks, streets, highways, commercial development, and local development plans are all potential site constraints that need to be considered.

The most important energy-related decision in any design is how to place and orient a building on a particular site. This is true even in cases where the building is built to the lot line. In the days before electricity and air conditioning, builders had to understand the principles of daylighting, natural ventilation and passive heating and cooling. Today, due to HVAC technology, it's easier to ignore the environment and still provide well-lit, comfortable buildings. Unfortunately, we sometimes take our reliance on technology too far: Every time we design and construct buildings that use more energy than necessary, we contribute to air and water pollution.

Benefits

Proper building placement and orientation can lead to energy savings and better natural light and ventilation, among other benefits. Building placement should also enhance a neighborhood and increase safety.

Planning for transit connection points and pedestrian and bike paths (*Planning & Design: Measure 04*) can foster community interaction and car-free travel.

Application

Building placement and orientation and considerations are applicable to all multifamily housing projects.

Design Details

A thorough walk-through and analysis of the site and its surroundings is imperative for determining correct building placement. To accurately understand the impacts of development on different areas of a site, studies may be necessary. Conduct site surveys, and check maps, climatic data and other sources to gain information on winds, solar potential, natural contours, geology, soil composition, hydrology, traffic, noise and more.

PROTECT OR RESTORE THE LOCAL ENVIRONMENT

- » Protect natural areas. On sites that have some existing vegetation, such as mature trees, wetlands or adjacent parks, consider protecting those areas and providing wildlife corridors (*Planning & Design: Measure 08—Landscaping / to read about an example of preserving mature trees, see the Betty Ann Gardens Case Study*).
- » Use trees for shading. Trees that shade the east or west side of a building during the summer can reduce cooling needs.
- » Restore wetlands. Creeks or wetlands can be augmented or restored with natural swales and stormwater retention ponds (*Planning & Design: Measure 10—Stormwater Management*).
- » Minimize the footprint. Minimizing the development footprint and providing permanent open spaces, either as wildlife preserves or parks, can help protect the local ecosystem.
- » Cluster units. Building upward instead of outward will help minimize the developed area, especially in rural or suburban areas. Clustering buildings also reduces material use because of shared walls, roofs and more. And energy used to heat and cool the buildings is reduced because each unit has less direct contact with the exterior.
- » Consider the effects of land clearing. When developing a site, consider the effects that land clearing and creating streets will have on a site. Instead of shearing off a hillside and removing the soil, build with the site's contours. Aim for balanced fill whenever possible—retain the soil removed for foundations and use it for landscaping (*for tips on handling and treatment of removed soil, see ACWMA's Bay-Friendly Landscaping Guidelines*).
- » Complement existing neighborhood patterns. Respect existing setbacks and consider the building's impact on solar access for neighboring sites. Pay attention to the spaces between buildings and immediately adjacent to buildings, so that they contribute to public life, rather than create safety problems. For example, create continuous street facades, as opposed to leaving large gaps between buildings.

Maximize Free Energy

A building's orientation can greatly affect heating and cooling energy use. Placing the building with its major surface areas facing south allow for the greatest amount of solar heating. Overhangs and sun-controlling devices can shade the building from summertime sun (*Systems: Measure 01—Passive Solar Heating*).

Buildings can be designed and oriented to help deflect cold winter winds. Also, the building design can take advantage of prevailing winds to aid in natural ventilation. Check local weather station data for wind speeds and direction. Consider setting up a monitoring system on the site if winds are perceived to be particularly strong, or if a wind-generation system is being considered (*Systems: Measure 15—Onsite Electricity Generation*).

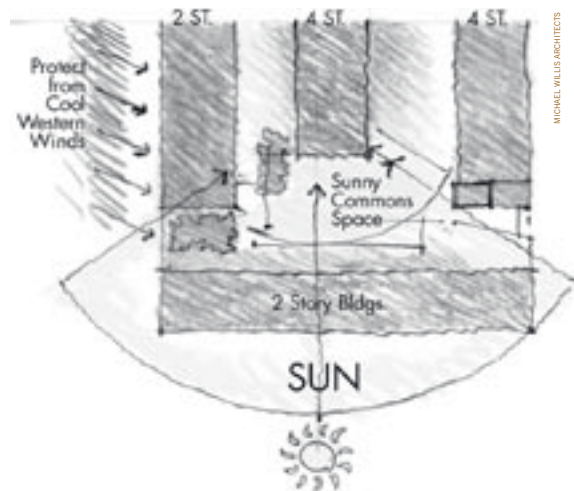

Wind and sun are used as design elements in this schematic design sketch.

CIRCULATION PATTERNS

Carefully planned wildlife corridors, bike paths, walkways and links to public transit will help integrate the development into the surrounding environment. Walking and bike paths can be set away from streets and connect to transit hubs, shopping centers, other trails and parks. Walkable and bikeable communities foster community interaction and reduce automobile use in urban environments (*Planning & Design: Measure 04—Design for Walking and Bicycling*).

PUTTING IT ALL TOGETHER

To effectively maximize all the benefits on a site, it is necessary to design multiple scenarios. The Carmen Avenue project in Livermore, CA (*see the case study in these Guidelines*) provides an excellent example of orientation, configuration and placement studies. The architects considered many different designs before making their final choice. Although the site is an urban setting, they were able to maximize solar gain and provide excellent circulation patterns.

Code Considerations

When considering a development's placement and orientation on a site, many codes apply for zoning, parking capacity, fire department access and more. If a local code is in conflict with preferred environmental or orientation strategies, consider raising the issue with local officials. Green building can mean rethinking existing laws, codes, policies and attitudes.

Considerations for Residents

Occupants may benefit from preserved natural areas, pleasant views, reduced heating and cooling bills, and more convenient connections to public transit.

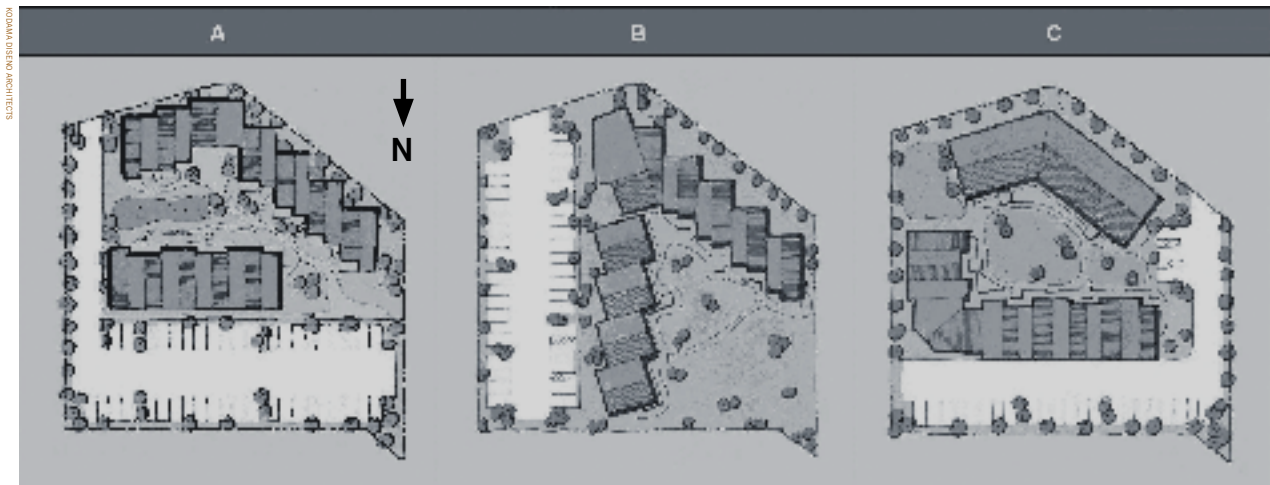

For the Carmen Avenue affordable housing development in Livermore, CA, project architects analyzed multiple schematic designs. Configuration “A” was chosen because it had the best solar access and parking configuration, and it created inviting spaces. See the case studies to learn more.

Cost and Cost Effectiveness

| | | |
|---------|--------|---|
| BENEFIT | ★★★ | Monitoring and researching a particular site's characteristics beyond standard practice can increase costs. However, if these steps are taken as part of an integrated design process, the result may include reduced heating and cooling needs, smaller stormwater treatment systems, and other cost-saving features (<i>for a discussion of integrated design, see the introduction to these Guidelines</i>). |
| COST | \$\$\$ | |

Resources

- » **Environmental Building News**, Vol. 7 No. 3 (March 1998), "Getting to Know a Place: Site Evaluation as a Starting Point for Green Design": www.buildinggreen.com
- » **PG&E** has numerous resources, including modeling tools and solar calculators, to help with siting and orientation. Most of these services are available free from the Pacific Energy Center in San Francisco: www.pge.com/pec

Numerous resources are available for obtaining data on a particular site:

- » **National Oceanographic and Atmospheric Administration** (NOAA) has data including design temperatures, degree-day averages, and more: www.noaa.gov
- » **National Renewable Energy Laboratory** provides solar insolation values: <http://rredc.nrel.gov/solar/>
- » **Wind data** is available from weather stations, airports, and some university libraries.
- » **ACWMA's Bay-Friendly Landscaping Guidelines** offer plant hardiness zone maps that help in selecting vegetation to meet the site's needs: www.multifamilygreen.org
- » **Sunset Magazine** landscape climate maps can be found at: www.sunset.com
- » **U.S. Department of Agriculture** Hardiness Zone maps can be found at the United States National Arboretum website: www.usna.usda.gov/Hardzon

DESIGN FOR WALKING AND BICYCLING

Design Developments for Safe, Pleasant Walking and Bicycling

| WHO | KEY BENEFITS |
|---|--|
| <ul style="list-style-type: none"> ✓ Developer/PM ✓ Funder ✓ Policymaker ✓ Architect ✓ Builder Resident Building Manager | <ul style="list-style-type: none"> ✓ Health/IEQ ✓ Site/Community Energy Efficiency Water Efficiency Material Efficiency ✓ O&M ✓ Resident Satisfaction ENERGY STAR® |
| <p>02870: Site and Street Furnishings</p> | |

Recommendation

Design buildings, sidewalks, pathways, streets and crossings to encourage walking and bicycling.

Build secure bicycle storage facilities on the site.

Description

Walking and bicycling are the cheapest and most sustainable forms of transportation, but they are often incompatible with conventional car-based development patterns.

Convenience, safety and aesthetics are key factors in promoting travel by foot and bicycle. Residents of developments that are well-connected to nearby amenities will be more likely to walk or bike to their destinations. Sidewalks and street crossings should be designed to provide safe and convenient pathways. Clearly differentiated vehicle, bicycle and pedestrian spaces will reduce traffic accidents. Articulated building facades and ground-floor commercial activity create a pleasing pedestrian environment.

Benefits

Walking and bicycling are excellent, inexpensive forms of physical activity that promote health. They provide alternatives to travel by car, a major source of air pollution and energy use.

Traffic-calming measures have led to lower pedestrian injury rates, greater neighborhood economic activity and increased public safety. Children, seniors and people with disabilities benefit most from increased mobility and safety.

Application

Applicable to all projects (*for related information, see Planning & Design: Measure 01—Infill Sites / Planning & Design: Measure 05—Social Gathering Places / Planning & Design: Measure 06—Design for Safety*).

Design Details

SIDEWALKS

Design sidewalks to be separated from roadways and to connect with existing city walkways. Base the sidewalk widths on street size and level of pedestrian activity. A width of at least 5 feet is necessary, while 6 to 7 feet is recommended to incorporate trees and meet requirements of the Americans with Disabilities Act.

Incorporate trees and other landscaping along the sidewalk to provide visual interest and a buffer between pedestrians and cars. Place landscaping features, trash receptacles, light fixtures and street furniture such as bus shelters and benches so that they do not impede the flow of pedestrians. The best location for these items is often in the utility zone—the strip of sidewalk between the walking path and the roadway. Pedestrians generally prefer lampposts that are more frequently spaced and less bright (*for outdoor lighting recommendations, see Systems: Measure 14—Light Pollution Reduction*).

PEDESTRIAN CROSSINGS

Locate street crossings no more than 300 feet apart. In areas with heavy pedestrian activity, more frequent spacing is recommended. Street crossings can be made safer by using crosswalk striping, enhanced signing, bulbouts or refuge islands. These measures can be used alone or in combination.

Bulbouts extend the sidewalk into the roadway to reduce the crossing distance for pedestrians. Refuge islands are located in the middle of a crosswalk, either as a stand-alone feature or part of a median. They provide a pedestrian stopping point and are particularly helpful when the roadway is very wide and has high traffic volumes. The crosswalk should be wide enough to accommodate a wheelchair.

TRAFFIC CALMING

High speeds and heavy traffic volumes increase accidents and discourage social interaction in neighborhoods, which can lead to public safety problems (*Planning & Design: Measure 06—Design for Safety*). Work with the city's engineering or public works department to implement these measures:

1. Designate bicycle lanes with proper signage and striping. A standard bike lane is 5 feet wide. If separate bike lanes aren't possible, use a 14-foot mixed travel lane for cars and bikes.
2. Design 10-foot vehicle travel lanes, rather than the standard 12 feet, to discourage fast driving. The remaining right of way can be used for bike lanes.
3. Consider narrowing roads in areas with a lot of foot traffic. For example, a four-lane roadway can be redesigned into two travel lanes, one turning lane, two bike lanes and a wider sidewalk.
4. Consider speed humps, rumble strips and raised crosswalks to reduce speeding.
5. Plant trees along streets to create visual interest and the perception of a narrower street, which reduces speeding.

BICYCLE PARKING AND STORAGE

Outdoor bicycle racks must be well-lit, secure and placed in a paved area. When possible, provide covered bicycle parking, such as underneath building overhangs.

Place racks in locations with high foot traffic and good visibility, such as near a building entrance or gathering place (*Planning & Design: Measure 05—Social Gathering Places / Planning & Design: Measure 06—Design for Safety*). If the development has multiple buildings or entrances, consider placing separate racks at each location to increase convenience.

When selecting bicycle racks, look for these features:

1. Both the bike frame and one wheel can be attached to the rack with a standard U-lock.
2. The rack should be firmly secured to the ground and sturdy enough to resist disassembly by thieves.
3. Spacing between bike slots must be wide enough to accommodate mountain-bike handlebars (typically 20 to 24 inches). For a “grid” or “wave” rack, a minimum width of 30 inches between verticals is recommended. Otherwise, the rack can only be used at full capacity if access is available from both sides.
4. In tight spaces, use “post and ring” or “inverted-U” racks that hold two bikes. U-racks should be at least 30 inches long, with 36 inches preferred. Otherwise they may be used to park only one bike.

A bike rack must be placed properly to maximize its capacity. Optimal spacing varies depending on the specific model. These recommendations are for a standard “grid” or “wave” rack:

1. When placing a rack perpendicular to a wall, leave 1.5 feet to allow a bike to be parked on the end space.
2. When placing a rack parallel to a wall, leave at least 2 to 2.5 feet from the wall. This spacing permits access from one side. Some racks can only be fully used when access is available from two sides. To allow access from the wall side, leave at least 5 feet of space.
3. When placing two or more bike racks parallel to one another, leave about 12 feet between them.
4. Inverted U-racks placed in parallel should be 4 feet apart.

Convert garage parking spaces into bicycle parking that will serve many more residents. For example, a single 16x8-foot car stall can accommodate twenty bikes in a two-level bike rack.

Individual lockers provide the most security and convenience for bicyclists, but they are expensive and require more space. Select storage lockers for durability and easy maintenance. Place them in high-visibility areas to deter theft.



Wave racks with wide spacing between slots will accommodate more bikes than narrow racks. Individual lockers offer the most security.

PARKING AND DRIVEWAYS

Reducing the amount of onsite parking is a key step toward creating a pedestrian- and bicycle-friendly environment. Parking spaces add to construction costs and encourage residents to drive when it may not be necessary. One way to discourage car ownership is to “unbundle” parking from housing. If parking is included with a housing unit, residents will effectively pay for it regardless of whether they need it. When housing units and parking spaces are rented or sold separately, residents who don’t need a space can save money.

Multifamily developers can also reduce their overall parking requirements by allocating spaces for City CarShare vehicles. This innovative car-sharing program allows residents and neighbors to enjoy the convenience of driving and avoid the expense and hassles of ownership.

Situate garages and parking structures so that they do not dominate the street. Visually screen parking garages, because they can discourage pedestrian activity. Consider wrapping ground-floor retail around a parking structure to hide it from view. Avoid using surface parking lots because they create gaps in street activity and are an inefficient use of land.

On-street parking is recommended, because it acts as a buffer between sidewalks and moving vehicles. However, diagonal parking can cause serious conflicts with bicycles because it is harder for drivers to see them.

Minimize driveway widths and frequency of spacing because they create additional hazards for pedestrians.

Code Considerations

Local codes may be a barrier to pedestrian- and bicycle-friendly design. Codes typically require road widths that exceed the recommended 10-foot lane width, while specified sidewalk widths are too narrow to accommodate multiple users. Regulations on signs, underground utilities, lighting and tree placement often don’t facilitate pedestrian activity or traffic calming.

Policymakers can adopt strategies to promote walking and bicycling, such as:

- » Place street furniture in locations that do not obstruct pedestrian traffic.
- » Promote mixed-use development and retail activity at the street level.

- » Eliminate minimum parking requirements for developments with good transit service.
- » Adopt parking policies that encourage walking within a destination area and sharing spaces among user groups.
- » Designate safe biking and walking routes and properly fund their maintenance.
- » Implement traffic calming strategies.

Considerations for Residents

Quality-of-life improvements include greater mobility and opportunities for physical activity.

Cost and Cost Effectiveness

| | | |
|----------------|---------|--|
| BENEFIT | ★★★ | Bicycle parking costs from \$25 per bike for simple racks to \$600 and up per bike for storage lockers. Car parking costs \$7,000 to \$30,000 per space. |
| COST | \$ \$\$ | |

Many pedestrian site design features cost nothing if incorporated early. The cost for fixing problematic infrastructure varies greatly. Striping crosswalks and installing street humps are relatively inexpensive, but widening sidewalks and installing refuge islands are costly. However, these actions may reduce injuries and fatalities.

Resources

- » **Walkable Communities:** www.walkable.org
- » **Local Government Commission**, street design guidelines and other resources: www.lgc.org
- » **City of Portland** Bicycle Parking Facilities Guidelines www.trans.ci.portland.or.us/bicycles/parkguide.htm
- » **RIDES** list of rack/locker manufacturers: www.rides.org/main/bicycleparkingatwork.htm
- » **Non-Profit Housing Association:** www.nonprofithousing.org (see *Action Center/ Tool Box on planning for parking*)
- » **City CarShare:** www.citycarshare.org

SOCIAL GATHERING PLACES

Create Pleasant Outdoor Gathering Places for Residents

| WHO | KEY BENEFITS |
|---|--|
| <ul style="list-style-type: none"> ✓ Developer/PM ✓ Funder ✓ Policymaker ✓ Architect ✓ Builder ✓ Resident ✓ Building Manager | <ul style="list-style-type: none"> ✓ Health/IEQ ✓ Site/Community Energy Efficiency Water Efficiency Material Efficiency ✓ O&M ✓ Resident Satisfaction ENERGY STAR® |
| <p>DIVISION 2: Site Construction</p> | |

Recommendation

Plan for outdoor spaces where residents can gather and interact without relying on cars.

Description

Multifamily housing often has community rooms or other common indoor facilities. Some of these spaces can be located outside to provide pleasant gathering places for residents. For example, outside benches, pathways, play surfaces for children, stages and other features can promote socializing.

Orienting the units' windows so that residents can easily view these outdoor areas will help keep the areas safe (*Planning & Design: Measure 06—Design for Safety*).

Consider clustering buildings on a site so that a significant portion of the site can be set aside for outdoor recreation. This is especially crucial in urban environments where parks and relaxation spaces may be scarce (*Planning & Design: Measure 03—Building Placement and Orientation*).

Benefits

Attractive social gathering spaces benefit the community in many ways. Walkable places improve public health by encouraging people to exercise. Vibrant public spaces draw people together, which encourages interaction and deters crime.

Application

All developments need well-designed public spaces. Developments in urban areas should maximize connections from the site to nearby activities. Rural sites can take advantage of parks and open space.

Design Details

Important design considerations for improving social interaction include aesthetics, parks and recreation, outdoor furnishings, pedestrian paths, outdoor “rooms,” and streets.

AESTHETICS

A development's sense of place arises from aesthetics as well as functional elements. Boring, out-of-scale or bland buildings create an unwelcome feeling, even if the development has useful amenities. Design sites and buildings to inspire people and encourage them to walk and exercise. Gathering places should provide interesting views of surroundings and people. Access for pedestrians needs to be safe so that people aren't afraid to take a walk.

PARKS AND RECREATION

Parks, basketball courts, community gardens, play areas and other outside recreation activities are an important part of livable places. Consider linking pathways from the development to bike paths, parks and shopping areas. Within the development, include small parks or activity areas.

FURNISHING PUBLIC SPACES

Many areas, whether they are transitional or designed for longer stops, can be enhanced to create pleasant gathering places. Chairs and benches provide spaces to rest, pause or talk with neighbors. Nontraditional elements like ledges, boulders and other landscaping elements can also provide seating. Encourage people-watching by allowing seated people to see in multiple



Providing a diverse range of seating features in the landscape will encourage outdoor interaction.

directions and have a clear view of transitory areas on site.

PEDESTRIAN PATHS

Pathways connect people to each other and the surrounding environment. Pathway design is integral to landscape design and building placement, and should be considered early in the design process. *(Refer to the green building timetable in the Guidelines' introduction for a summary of where each measure fits into the overall design process.)*

Design pathways to accommodate the wide range of people and equipment that will share the paths: bikers, walkers, strollers, furniture movers, shopping carts and more. Having adequate space will encourage residents to spend more time socializing, even if a bicyclist or moving crew are passing by *(Planning & Design: Measure 04—Design for Walking and Bicycling)*.

Where paths intersect, place benches, boulders and other elements to encourage people to linger and chat. Sand boxes, for example, are a good place for kids to play while adults talk.

OUTDOOR "ROOMS"

Lay out the site so that buildings form outdoor spaces or rooms. These spaces or rooms can then accommodate a variety of uses. Take advantage of the Bay Area's mild climate and extend small residential units by connecting directly to patios, porches and other outdoor spaces. Locate windows and doors of the surrounding units so that they look out onto these spaces to enhance safety *(Planning & Design: Measure 06—Design for Safety)*.

Design areas where residents can garden or have potted plants near their homes. Patios with low fences encourage interactions with passersby.

STREETS

Some multifamily projects will have streets or roadways that can be designed to encourage walking and biking. Studies show that people living on streets with low vehicular traffic have up to three times as many neighborhood friends and acquaintances than those living on busy streets. Traffic-calming methods like narrow, meandering streets and adequate walkways help get people out of cars and into the community *(Planning & Design: Measure 04—Design for Walking and Bicycling)*.

Code Considerations

Local codes such as zoning, parking capacity and fire department access may affect the design of social gathering places. If a local code is in conflict with preferred strategies, consider discussing this issue with local officials early in the design process.

Considerations for Residents

Occupants benefit from increased access to leisure activities that promote neighborhood cohesion.

Cost and Cost Effectiveness

| | | |
|----------------|--------|--|
| BENEFIT | ★★★ | There is evidence that neighborhoods with a strong sense of community and with walkable access have higher property values and are attractive to homebuyers. |
| COST | \$\$\$ | |

Designing for social interaction should not add significant costs to a project.

Resources

- » **Project for Public Spaces:**
<http://pps.org/buildings>
- » **Local Government Commission** fact sheets:
www.lgc.org
- » **Affordable Sustainability:**
www.homeasta.org
- » **U.S. Department of Housing and Urban Development's** Affordable Housing Design Advisor:
www.designadvisor.org

DESIGN FOR SAFETY

Design Buildings and Landscapes to Promote Safety

| WHO | KEY BENEFITS |
|---|---|
| <ul style="list-style-type: none"> ✓ Developer/PM Funder Policymaker ✓ Architect ✓ Builder Resident ✓ Building Manager | <ul style="list-style-type: none"> ✓ Health/IEQ Site/Community Energy Efficiency Water Efficiency Material Efficiency ✓ O&M ✓ Resident Satisfaction ENERGY STAR® |

DIVISION 2: Site Construction

Recommendation

Design buildings and landscapes to deter crime and promote safety.

Description

While it may be possible to deter crime with tall fences, video surveillance and bright lights, these elements also deter outdoor play and neighborliness. They should be used only when absolutely necessary. The most secure communities have design elements that foster rather than discourage human interaction.

Most experts agree that creating a greater sense of community in residential areas results in safer living. Strategies for promoting safety include encouraging community interaction, controlling access to the site, creating comfortable conversation and seating areas near building entrances so that people can keep an eye on their neighborhood, and reinforcing the territorial differences between private and public areas.

Benefits

Safe and attractive exterior spaces benefit the community in many ways. Walkable places improve public health by increasing exercise opportunities for residents. Vibrant spaces draw people together, which encourages neighborly interaction and can deter crime.

Application

Applicable to all projects *(for information on mixed-use development, building placement and orientation, planning for walking and bicycling, social gathering places, and vandalism prevention, see Planning & Design: Measure 02, 03, 04, 05 and 07).*

Design Details

ENCOURAGE COMMUNITY INTERACTION

Create visual connections between interior and exterior spaces. Design units so that kitchen windows look onto prominent circulation paths. Living rooms can overlook streets and other outdoor spaces.

Create semi-private outdoor spaces. Take clues from successful patterns in the surrounding community. Porches, balconies and even a front door area sheltered by a deep eave provide comfortable places to sit. When residents keep an eye on their neighborhood, crime may be significantly deterred.

Create public gathering places. A big flat rock at an intersection of two or more paths, for example, attracts more people than a bench. A community garden or a low sitting wall near a play area also helps promote a sense of community. These gathering spaces should be easy to supervise from the surrounding units.

Retail space in mixed-use developments increases daytime activity and generally improves security *(Planning & Design: Measure 02—Mixed-Use Developments).*

CONTROL ACCESS TO A SITE

Provide highly durable hardware at all common entry doors. Broken doors can compromise security and require costly repairs. If a reception area is located near the main entrance, provide a clear view of visitors by properly positioning the reception desk and using adequate vision glazing.

Make all entrances to the development highly visible. Main entrances should be prominent and clearly visible from the street and common areas. Cluster common indoor areas—such as lobbies, mailrooms and laundry areas—around main entrances to help define the development’s access pathways *(Systems: Measure 18—Central Laundry).*

Control public access to exterior courtyards and play structures, particularly in dense urban environments. Residents will be more likely to use the outdoor areas if they are secure.

Break up parking lots into smaller, localized lots that reduce walking distances to units. Design windows in kitchens, living rooms, dining rooms, and other well-used spaces to look out on parking lots and open areas. Clearly mark all visitor parking spots and make them easily visible.

In below-grade or enclosed parking structures, provide a limited number of entryways. These should be well-lit and clearly visible to passersby and residents. Eliminate potential hiding spots that are out of view, such as dark and enclosed stairways.

DESIGN FOR NATURAL SURVEILLANCE

Provide windows that overlook communal areas and have a line of sight to stairways, play areas, and other potentially unseen spots. Design balconies to look out on common areas. Visitors standing outside a unit’s door should be visible from inside the unit, even for children.

Design landscaping to allow for surveillance. Keep shrubs and hedges to less than 3 feet tall near buildings to prevent people from hiding behind them. Consider planting flowerbeds underneath windows so that someone standing in them looks suspicious. Burglar-proof plants, such as thorny bushes, near windows and doorways are also helpful. Trim tree branches up to 6 feet off the ground to increase visibility around trees.

Lighting helps with surveillance and safety at night. Lighting does not have to be bright, but it should be uniform. Remember to shield fixtures (*Systems: Measure 14—Light Pollution Reduction*). Consider using occupancy sensors or photocell controls on outdoor lighting to save energy (*Systems: Measure 13—High-Efficiency Lighting*).



The courtyard at Betty Ann Gardens has many elements for natural surveillance: balconies that look toward a central area, benches to encourage leisure time, and proper site lighting.

PROVIDE TERRITORIAL REINFORCEMENT

Gates and fences are one way to discourage trespassing, but landscaping and other attractive visual cues may be better ways to help differentiate private from public areas. Design building entries to promote a feeling of ownership. Steps, fences, pathways, lighting and overhangs can create a transition space between public and private areas in low-density housing. In dense buildings, various strategies can be used to create a buffer between public spaces and private units, such as providing relief in interior corridors at unit entries, creating a recessed doorway with a small overhang for a porch-like entry, or distinguishing the unit’s entry with a special light fixture. Areas without these buffer zones may seem unwatched, which may encourage crime.

MAKE MAINTENANCE A PRIORITY

To effectively provide safety, a building and its grounds need to be well tended. Maintain landscaping and create good storage for bicycles and children’s toys on the ground floor. Promote good housekeeping of common areas, and locate the janitor closets in convenient places to make it easier to do regular and special maintenance. If graffiti or vandalism occurs, remedy the situation quickly to discourage repeat incidents (*Planning & Design: Measure 07—Vandalism Deterrence and Management*).

Code Considerations

Lighting requirements generally stipulate a minimum and average footcandle level for outdoor areas. Funders or cities may have requirements for entryway designs or security features in crime-ridden neighborhoods. The recommendations presented here will enhance the security of any project that meets these other requirements.

Considerations for Residents

Reduced crime, improved relationships with neighbors, better community appearance and better quality of life.

Cost and Cost Effectiveness

| | | |
|----------------|--------|--|
| BENEFIT | ★★★ | May add some minimal design time and potentially some cost for benches, overhangs and similar elements. To avoid increasing cost, use elements with dual functions, such as overhangs on south exposures. Prioritize site planning and minimize added features to reduce cost. |
| COST | \$\$\$ | |

Resources

- » **Local Government Commission** has fact sheets on community design, traffic calming and safety: www.lgc.org
- » **U.S. Department of Housing and Urban Development’s Affordable Housing Design Advisor**: www.designadvisor.org
- » **Project for Public Spaces** has excellent resources on designing secure public spaces: http://pps.org/buildings/info/how_to/security

VANDALISM DETERRENCE AND MANAGEMENT

Tips for Reducing Vandalism and Graffiti

| WHO | KEY BENEFITS |
|--------------------|-------------------------|
| Developer/PM | ✓ Health/IEQ |
| Funder | ✓ Site/Community |
| Policymaker | Energy Efficiency |
| ✓ Architect | Water Efficiency |
| ✓ Builder | Material Efficiency |
| ✓ Resident | ✓ O&M |
| ✓ Building Manager | ✓ Resident Satisfaction |
| | ENERGY STAR® |

DIVISION 2: Site Construction, **DIVISION 9:** Finishes

Recommendation

Take steps to protect the development against vandalism during and after construction to reduce wasted materials and costly replacement.

Description

Vandalism may occur throughout construction and afterward, and can lead to early failure of building components. It is also frustrating for residents and facility staff, and can lead to costly repairs.

During construction, reduce vandalism by monitoring the site and restricting access to areas prone to vandalism and graffiti.

Once a building is occupied, designs that promote interaction among neighbors, walkable areas, and good maintenance will lessen vandalism (for more about designing for walking and bicycling, social gathering places and safety, see *Planning & Design: Measure 04, 05 and 06*).

Benefits

Deterring vandalism results in cleaner, safer communities. Quick response to incidents will increase residents' morale and discourage future vandalism.

Application

Protection against vandalism applies to every project, and is especially applicable in crime-prone areas.

Design Details

DURING DESIGN

Many physical features that contribute to a project's sense of place can discourage vandalism. Create clearly marked access ways with good lighting and physical barriers to prevent hiding spots. Provide views from each residential unit. Provide clearly marked and centrally located entrances with good lighting. Design landscaping to deter vandals. (*Planning & Design: Measure 06—Design for Safety*)

Some specific vandalism control strategies are:

- » **Provide a constructive outlet for youths.** Most vandalism is caused by teens and young adults. Providing basketball courts, parks, and walking and biking access to activities are good ways to encourage positive behavior.
- » **Use durable and vandal-proof materials.** The most vital points are walls, windows, doors and entryways.
 - »» **Walls.** It can be difficult to remove graffiti from porous siding materials like stucco. Fiber cement, aluminum and composite siding can provide a better defense against graffiti (*Structure: Measure 10—Durable Siding*). Avoid large, clear wall areas that invite graffiti. Design staggered surfaces instead of smooth and flat ones. Alternatively, encourage children or local artists to paint murals in these areas.
 - »» **Windows.** Unmonitored windows may attract vandalism more than windows in visible locations. Also, consider using raised-floor construction or otherwise raising the height of ground-floor windows to put them out of easy reach.
 - »» **Doors/Entries.** Use high-quality metal or solid-core doors with durable hardware and locksets, especially in remote areas on the site. Entries should be well lit, with shields or valances to reduce light pollution (*Systems: Measure 14*), motion sensors, and steps or pathways to help distinguish public from private zones (*Planning & Design: Measure 06—Design for Safety*).
- » **Use darker paint on walls.** Darker paint, especially at ground level, helps discourage vandalism. Also, it is easier to paint over graffiti on dark surfaces (graffiti may show through light-colored paint).
- » **Use anti-graffiti coating.** On surfaces likely to attract graffiti, apply an anti-graffiti coating, which is usually a water- or oil-based clear coat that can be easily cleaned.
- » **Protect walls with landscaping.** Plants such as vines and fast-growing creepers are an economical way to protect walls and fences against tagging. However, rodents and other pests can be a concern when vines cover walls.

ON THE CONSTRUCTION SITE

Early involvement of the community with the project can help protect against graffiti, theft, trespassing and vandalism on the construction site. Neighbors and community groups with a stake in the development are more likely to pay attention to activities on the site.

Neglected areas invite disrespect and crime more than clean, well-tended spaces. Regularly clean job sites and provide adequate physical barriers around vandalism-prone areas, such as back walls and alleyways.

POST-CONSTRUCTION

Create a vandalism management plan to counteract damage that may occur. Remedy any vandalism and graffiti within twenty-four hours. Show clear ownership and pride in the development by conducting regular maintenance and cleaning.

When cleaning up graffiti, use the least toxic means available. Use stain-hiding paints for covering graffiti on wood and walls. Harsh cleaners may be needed to clean porous surfaces like brick.



This job site was not vandalized, but it looks as though it could have been. A clean and well-maintained site and building discourages vandals.

Code Considerations

Some jurisdictions may have anti-blight ordinances that require cleanup of graffiti and construction jobsites both during and after construction. Developers and property managers should check with local officials for details.

Considerations for Residents

Occupants benefit from improved quality of life, a more attractive home, and reduced crime. In the mid-1980s, the New York Police Department found that cleaning the graffiti off the subway trains reduced violent crime by more than 80%. The theory is that criminals are less likely to act when they are in an orderly, well-kept space.

Cost and Cost Effectiveness

| | | |
|----------------|-----|--|
| BENEFIT | ★★★ | Very cost effective. Most strategies do not add cost beyond standard practice. |
| COST | \$ | |

Resources

- » **City of Oakland's** graffiti abatement hotline: (510) 238-4703
- » **City of Sioux Falls, South Dakota** graffiti brochure (download Planning & Design, MeasureF file): [www.siouxfalls.org/health/media/graffiti.Planning & Design, MeasureF](http://www.siouxfalls.org/health/media/graffiti.Planning%20&%20Design,MeasureF)
- » **State of Victoria (Australia)**, Department of Education has useful tips for preventing graffiti, vandalism and other crime: www.sofweb.vic.edu.au/emerg/crimprev/index.htm

LANDSCAPING

Create Healthy Landscapes, Build Healthy Soils and Reduce Waste

| WHO | KEY BENEFITS |
|--|--|
| <ul style="list-style-type: none"> ✓ Developer/PM Funder Policymaker ✓ Architect Builder Resident ✓ Building Manager | <ul style="list-style-type: none"> Health/IEQ ✓ Site/Community ✓ Energy Efficiency ✓ Water Efficiency ✓ Material Efficiency ✓ O&M ✓ Resident Satisfaction ENERGY STAR® |

Recommendation

Work with the natural ecosystems of the San Francisco Bay Area to foster soil health, reduce runoff and pollution, prevent and reuse plant waste, and conserve water and other natural resources.

Design, construct and maintain healthy landscapes while sustaining resources and protecting the environment.

Description

Conventional landscaping often relies on large lawns, non-native plants, abundant irrigation and heavy use of synthetic fertilizers and pesticides. It also requires frequent mowing, blowing, trimming and removal of plant debris.

These practices destroy beneficial organisms, consume significant resources, pollute air and water and deplete soil of organic matter and nutrients, degrading soil health. The result is an increased production of plant debris, increased dependency on fertilizers and irrigation, as well as greater stormwater runoff, erosion and pollution of the Bay.

The Alameda County Waste Management Authority's *Bay-Friendly Landscaping Guidelines* describe an integrated solution to these problems. The seven principles for Bay-Friendly Landscaping are:

- » **Landscape Locally.** Understand and consider the native plant communities, climate, soils and topography of the Bay Area.
- » **Landscape for Less to the Landfill.** Choose appropriate plants and reuse plant debris and other materials onsite.

- » **Nurture the Soil.** Feed the soil, not the plant, to encourage soil functions such as nutrient cycling, water holding capacity, disease suppression and pollutant removal.
- » **Conserve Water.** Create drought-resistant landscaping and use water efficiently by choosing appropriate plants, soil treatments and irrigation systems.
- » **Conserve Energy.** Choose equipment carefully and design to moderate building temperatures and reduce the heat island effect.
- » **Protect Water and Air Quality.** Use integrated pest management, and choose plants and equipment that protect the quality of our water and air.
- » **Create Wildlife Habitat.** Create environments that provide habitat for wildlife by diversifying landscapes, providing water and shelter, and replacing pesticides with beneficial organisms that keep pests under control.

Benefits

Bay-Friendly Landscaping works with nature to build healthy soils, reduce waste and protect ecosystems of the Bay Area.

Bay-Friendly Landscaping is also good business. In many cases, implementing the practices recommended in ACWMA's Guidelines can:

- » Reduce labor, water and chemical costs
- » Prevent plant loss and replacement expenses
- » Reduce hauling and disposal fees
- » Protect worker health and safety
- » Meet the needs of the owner and community by creating aesthetically pleasing, functional and low-maintenance landscapes

Application

All multifamily developments.

Design Details

When applying the *Bay-Friendly Landscaping Guidelines'* seven principles, use these environmentally sound practices:

- » **Landscape Locally.** Evaluate climate, exposure and topography; assess the soil and test drainage; survey and protect flora and fauna; consider the potential for fire; and learn about local, natural plant communities and use them as models.
- » **Landscape for Less to the Landfill.** Select plants that match the soil and microclimate, grow to their natural size in the space allotted without shearing, and aren't invasive; grasscycle (when mowing, leave grass

clippings on the lawn to decompose and feed the soil); produce mulch from plant debris and compost landscape debris; prune, water and fertilize selectively and judiciously; and use recycled content materials or salvaged items in designing hardscapes. (*Planning & Design: Measure 13—Recycling Collection, Planning & Design: Measure 14—Recycled Products, and FF8—Reclaimed Materials*)

- » **Nurture the Soil.** Remove and store topsoil during construction; protect the soil from compaction; defend against erosion; amend the soil with compost before planting; grasscycle; mulch existing planting beds regularly; aerate compacted soils; feed soils naturally with compost or compost tea; and avoid or minimize the use of synthetic fertilizers and chemical pesticides. (*Planning & Design: Measure 10—Stormwater Management*)
- » **Conserve Water.** Use compost and mulch to create drought-resistant soils; select California natives or Mediterranean plants; minimize lawns; implement hydrozoning (grouping plants by their water needs); design for onsite rainwater collection and graywater use; install and maintain high-efficiency irrigation systems; install a separate meter to monitor water use in large landscapes; water according to need—make every drop of water count; and request an irrigation audit.
- » **Conserve Energy.** Moderate building temperatures by planting trees that provide shade and wind breaks; reduce the heat island effect by creating shaded paved areas; shade air conditioners (but do not block their air flow); design outdoor lighting carefully; choose and maintain equipment for fuel conservation; and specify local products and suppliers. (*Systems: Measure 14—Light Pollution Reduction / Planning & Design: Measure 09—Cool Site*)
- » **Protect Water and Air Quality.** Use integrated pest management to prevent and control pest problems; eliminate decorative lawns that require high inputs of water and chemicals; keep soil covered; choose and maintain equipment carefully; minimize impervious surfaces; plant trees; amend the soil in beds with

compost before planting; keep organic matter where it belongs—on the land, not in the landfill; maintain irrigation systems; and design a system to capture and treat stormwater and irrigation runoff.

- » **Create Wildlife Habitat.** Diversify landscapes to resist disease and insect pests; grow California native plants to provide food and shelter for local wildlife while bringing year-round beauty to the landscape; provide water and shelter for wildlife; eliminate the use of



Landscapes with native and Mediterranean plants require little or no irrigation once established and provide a sense of the seasons.

pesticides by fostering beneficial organisms to keep pests under control; nurture soil life with mulch and compost; and conserve or restore natural areas.

Code Considerations

Some communities have landscaping requirements that discourage or prevent environmentally sound landscaping practices. Work with Planning Department staff to explore exemptions from these local requirements, especially during the Design Review process for new construction projects.

Considerations for Residents

Avoiding residents' exposure to pesticides is an important benefit to occupants; children and pets who play outdoors and come in contact with soils and plants are especially vulnerable. Pesticides are also easily brought into the home and deposited on floors and carpets via foot traffic.

A healthy, vibrant landscape presents a positive image to the community and fosters pride among the building's residents.

Composting and other community gardening efforts can encourage community interaction, and teach residents about the effect of their actions on the local environment.



A vibrant landscape fosters pride among residents.

Cost and Cost Effectiveness

| | | |
|---------|---------|--|
| BENEFIT | ★★★ | Designing and constructing a Bay-Friendly Landscape does not have to cost more. In fact, significant cost savings can be achieved over time by: reducing labor, water and chemical costs; lowering plant loss and replacement expense; reducing hauling and disposal fees; and preventing or minimizing damage to fencing, sidewalks and other hardscapes. |
| COST | \$ \$\$ | |

It is important to find a landscape architect and maintenance company that understand and can implement the seven principles of Bay-Friendly Landscaping.



Checkerspot butterfly on native yarrow plant.

Resources

- » **ACWMA's Bay-Friendly Landscaping Guidelines**, as well as other ACWMA resources, provide information on environmentally friendly landscaping design and maintenance. Search the Materials Database for product information:
www.multifamilygreen.org
(510) 614-1699
- » **UC–Davis Statewide Integrated Pest Management Program** has numerous online resources:
www.ipm.ucdavis.edu
- » **California Native Plant Society** has information about native plants: www.cnps.org
- » **California Integrated Waste Management Board** provides information on resource-efficient landscaping and links to related sites: www.ciwmb.ca.gov/Organics/Landscaping
- » ***Sustainable Landscape Construction: A Guide to Green Building Outdoors***, by J. William Thompson and Kim Sorvig, Island Press (2000).
- » **Alameda County Water District** offers business water audits and landscape partnerships: www.acwd.org
- » **EBMUD Water Conservation Division** offers free commercial landscape irrigation audits, and irrigation upgrade programs:
Email: wfrserv@ebmud.com
www.ebmud.com
- » **Zone 7 Water Agency** (serving Livermore–Amador Valley) has tips for landscaping and irrigating wisely. Go to www.zone7water.com/conservation.html and click on Conservation Connection.

COOL SITE

Mitigate the Heat Island Effect

| WHO | KEY BENEFITS |
|--|---|
| <ul style="list-style-type: none"> ✓ Developer/PM Funder Policymaker ✓ Architect ✓ Builder Resident Building Manager | <ul style="list-style-type: none"> Health/IEQ ✓ Site Protection ✓ Energy Efficiency Water Efficiency ✓ Material Efficiency O&M ✓ Resident Satisfaction ENERGY STAR® |
| DIVISION 2: Site Construction | |

Recommendation

Reduce the urban heat island effect by:

- » Using light-colored paving materials with an albedo* of 0.30 or greater.
- » Installing open-grid paving systems.
- » Providing shade with trees, overhangs and building elements that covers 30% or more of all hard surface paving.
- » Using a Cool Roof *(Structure: Measure 12)*.

*Total solar reflectance—or albedo—is the ability of a material to reflect heat away from its surface and back into space.

Description

Paved surfaces make up 30% to 40% of developed urban areas, and contribute to what is called the “heat island effect.” Little sunlight is reflected off dark asphalt, so its temperature rises far above the ambient air temperature. As a result, cities experience temperature rises of as much as 5°F above surrounding rural areas. Higher outdoor temperatures lead to higher temperatures inside buildings, driving up cooling loads.

The most effective ways to reduce heat are to limit hard surface paving, provide shade and use light-colored paving materials.

Benefits

Cool sites reduce air-conditioning loads, improve comfort and extend the life of paving materials. Light-colored paving materials last longer than darker surfaces due to reduced thermal expansion and contraction. Citywide, air quality is improved because cooler air slows the chemical reaction that produces smog.

Application

Cool site measures are most important in urban environments where large areas of asphalt and buildings retain heat and increase temperatures.

Design Details

The most effective way to reduce thermal pollution is to reduce paved areas. Paved areas should not be wholly eliminated; children, for example, spend much of their play time on paved surfaces. Nevertheless, reducing paved areas can result in lower material costs and improved ecosystems.

COOL PAVING STRATEGIES

- » **Light-colored materials.** Choose light-colored pavers, aggregates or top coats, preferably with a reflectivity of 0.30 or higher. Parking lots, sidewalks, roads, driveways and other surfaces can have coatings or integral colorants added to increase reflectivity. Even light gray and tan colors may reduce surface temperatures by 20 to 40°F. Consider using light-colored concrete, or, if paving with asphalt, applying a white aggregate as a chip seal layer, or a light-colored surface coating such as a zinc-oxide slurry mix.
- » **Open-grid paving systems.** Install prefabricated concrete or plastic paving systems. The openings can be filled with light-colored gravel to improve reflectivity. Alternatively, grasses or other groundcover can be planted in the openings to provide cooling through evaporation while also retaining and filtering stormwater on site.
- » **Granite or crushed rock.** Use decomposed granite or other compacted crushed rock instead of asphalt for non-handicapped parking stalls and walkways. Gravel reflects and sheds heat better than paving and is preferable for stormwater management because of its porosity *(Planning & Design: Measure 10—Stormwater Management)*.
- » **Concrete and concrete pavers.** Standard concrete mixes can be used to achieve a high reflectivity. Choose nonporous concrete blocks with lighter colors, such as light gray, beige or tan.

- » **Resin modified emulsion pavement.** For developers looking to try something new, these products are an alternative to asphalt. They use clear binders made of tree resins instead of petroleum products. Light-colored aggregates suspended in the resin as coloring will increase reflectivity.

SHADING HARD SURFACES

Shade 30% or more of asphalt areas to greatly reduce surface temperatures. One of the best methods is to plant trees, which provide shade and cool the air through evapotranspiration. Here are some recommendations for shade trees (for related information, see *Planning & Design, Measure 03—Landscaping*):

- » Calculate shading by estimating the diameter of the tree crown after five years.
- » Select trees that are appropriate for the site in terms of soil type, water use and exposure.
- » Choose trees that will be allowed to grow to their natural shape and size in the allotted space.
- » Do not allow smaller-size substitutions after the plans have been approved.
- » Ensure trees are actually planted and that they are not removed after planting.

Trellises and other architectural elements can also provide shade (*Planning & Design: Measure 03—Building Placement and Orientation*). Covered parking spaces shade cars and make a convenient place to mount photovoltaic panels (*Systems: Measure 15—Onsite Electricity Generation*).



Streets with trees provide natural cooling on hot days.

Code Considerations

Some jurisdictions may require that hard surface materials have a minimum reflectance value to reduce the heat island effect. Some municipalities may also have ordinances that require a minimum number of trees be planted in parking lots. Check with local officials for preferred tree species.

Considerations for Residents

More comfortable outside environment, better air quality, reduced car temperatures in parking lots, and marginal reduction of cooling costs.

Cost and Cost Effectiveness

| | | |
|----------------|--------|--|
| BENEFIT | ★★★ | Costs vary greatly. Adding colorants and pigments to mixes of concrete and asphalt does not generally increase costs. Changing aggregate colors is also typically not expensive. Concrete is considerably more expensive than asphalt. Resin modified emulsion pavement is more expensive than concrete in small quantities. |
| COST | \$\$\$ | |

Resources

- » **California Energy Commission**, Cool Strategies: www.energy.ca.gov/coolcommunity/strategy/coolpave.html
- » **American Concrete Pavement Association**: www.pavement.com
- » **LEED** guidelines for shading nonroof surfaces: www.usgbc.org
- » **Lawrence Berkeley National Laboratory's (LBNL) Heat Island Group**: <http://eetd.lbl.gov/HeatIsland>
- » **Building Green**, publisher of *Environmental Building News*, has information on cool sites: www.buildinggreen.com
- » **Collaborative for High Performance Schools (CHPS) Best Practices Manual, Volume II—Design**, has details about cool sites: www.chpse.net
- » **ACWMA's Materials Database** lists products that correspond with this measure: www.multifamilygreen.org

STORMWATER MANAGEMENT

Strategies for Retaining and Treating Runoff Water

| WHO | KEY BENEFITS |
|---|--|
| <ul style="list-style-type: none"> ✓ Developer/PM Funder Policymaker ✓ Architect ✓ Builder Resident ✓ Building Manager | <ul style="list-style-type: none"> Health/IEQ ✓ Site/Community Energy Efficiency ✓ Water Efficiency Material Efficiency ✓ O&M Resident Satisfaction ENERGY STAR® |
| <p>02630: Storm Drainage</p> | |

Recommendation

Design permeable pavement surfaces and treatment systems to control stormwater runoff and minimize pollution.

Description

In an average undisturbed landscape, only 15% of rainwater leaves the site through surface water runoff. More than one-third moves into the soil where organisms break down and naturally filter pollutants before the rainwater reaches groundwater or surface waterways. As land is developed with buildings, parking lots and other impervious surfaces, two major changes occur:

- » More stormwater runs off the site. On developed sites, as much as 70% of all rain and irrigation water flows into waterways (via storm drains) without moving through soil.
- » The soil supports less microbial life and is less able to filter harmful chemicals out of the little water that moves through the soil.

Watershed quality decreases rapidly when the total impervious area exceeds 10% of a site. Pollutant load also increases. One acre of parking lot, for example, collects as much as four gallons of oil, gasoline and diesel fuel each year. When rainwater runs off the parking lot, these pollutants end up in our waterways. Other pollutants include pesticides, fertilizers, pet waste and suspended soil particles from poorly vegetated ground.

Steps can be taken to increase stormwater retention on site, which reduces runoff and pollution and helps filter and treat stormwater. The first step is to minimize impervious surfaces through landscaping practices

and using pervious paving. Another step is to design features into the site that channel runoff to swales, porous surfaces and holding areas (*Planning & Design: Measure 08—Landscaping*). Another strategy is to install systems that filter and treat stormwater as it leaves a site.

Benefits

Increasing porous surfaces decreases runoff and protects the health of watersheds, creeks, wetlands and other bodies of water. Reducing runoff improves soil health because it retains valuable topsoil onsite.

Retaining rainwater on site reduces runoff and filters pollutants. Downstream engineering costs may be decreased as well.

Application

When building on undeveloped sites (greenfields), design the site so that stormwater rates and quantities are not increased from predevelopment levels. Runoff from the development is either absorbed or captured on site through porous paving, bioswales, trenches and ponds.

With previously developed sites, plan for no net increase in runoff rate and quantity, or ideally, a net decrease of runoff post-development. Stormwater treatment in urban areas typically includes proprietary treatment systems because of limited space for natural filtering and separation.

Design Details

Planning for appropriate stormwater retention and treatment should be done as part of an integrated design process (*see the introduction to these Guidelines*). Consider the building location and the surrounding environment carefully because they greatly affect stormwater generation (*Planning & Design: Measure 03—Building Placement and Orientation*).

To lessen stormwater impacts on watersheds, reduce the flow (rate and quantity of runoff), and provide treatment through filtering and retention.

MINIMIZE IMPERVIOUS SURFACES

Typical housing projects have 25% to 50% impervious surfaces, or more. In most cases, alternative surfaces can be used that allow rainwater to soak in. Many porous surface options also reduce the heat island effect (*Planning & Design: Measure 09—Cool Site*). Some recommendations are:

- » Keep impervious surfaces to a minimum. Use porous surfaces, including permeable paving, and maximize landscaped areas to encourage infiltration. Asphalt and concrete for parking lots and driveways can be formulated to be porous although they may require more maintenance than traditional paving choices.

Note: groundwater contamination issues from vehicle fuel and other pollutants must be considered. An experienced pavement engineer can assist with pollution controls, soil testing and proper design.

- » Use crushed rock, gravel and mulch instead of hard surfaces.
- » Install open-grid pavers with low-growing groundcover (*Planning & Design: Measure 09—Cool Site*).
- » Avoid contiguous impervious surfaces so that the maximum amount of runoff water has some contact with soil before it exits the site.



Swales are attractive landscape features that absorb and filter stormwater runoff, reducing pollution.

bioswales. In dense urban areas, an alternative to porous pavement is a vegetated swale system that feeds into a storm drain, such as is used in some parking lots.

Finally, consider additional treatment products such as oil/grit separators or oil/water separators for removing pollutants from stormwater.

Code Considerations

Water detention features such as ponds may be a concern where children are present. Local municipalities may place new restrictions on stormwater discharge; check the latest regulations.

Considerations for Residents

Residents may benefit from attractive landscaping, increased property value, and protection of local streams and waterways.

Cost & Cost Effectiveness

| | | |
|---------|--------|--|
| BENEFIT | ★★★ | Pervious paving surfaces can cost more than hard surfaces, but can sometimes reduce costly stormwater treatment systems. |
| COST | \$\$\$ | |

Proprietary treatment products require regular maintenance and are more costly to operate than nonmechanical systems such as swales or ponds.

Green roofs are potentially good for saving energy and giving a project a unique look, but are costly.

Resources

- » **ACWMA's Bay-Friendly Landscaping Guidelines** and Materials Database: www.multifamilygreen.org
- » **Center for Watershed Protection:** www.cwp.org
- » **Environmental Building News** (Feb. 2002), article on treatment systems: "Cleaning up Stormwater: Understanding Pollutant Removal from Runoff": www.buildinggreen.com
- » **Start at the Source: Design Guidance Manual for Stormwater Quality Protection.** Describes techniques and considerations for the planning and design phase of development projects. www.ci.san-jose.ca.us/planning/sjplan/counter/stormwater/startatsource.Planning & Design, Measuref
- » **The Concrete Institute** provides information on pervious concrete and clay soils: Tel: (916) 722-2035

ENERGY STAR® – CERTIFIED HOMES

Achieve ENERGY STAR® Certification on Low-Rise Buildings

| WHO | KEY BENEFITS |
|--|--|
| <ul style="list-style-type: none"> ✓ Developer/PM Funder Policymaker ✓ Architect ✓ Builder Resident Building Manager | <ul style="list-style-type: none"> ✓ Health/IEQ Site/Community ✓ Energy Efficiency Water Efficiency ✓ Material Efficiency ✓ O&M ✓ Resident Satisfaction ✓ ENERGY STAR® |

Recommendation

For low-rise developments (three stories or less), design and construct homes that beat California’s Title 24 by 15% or more to earn the ENERGY STAR® certification. Perform a third-party verification of energy savings by a certified Home Energy Rater (HERS).

Buildings consisting of four or more habitable stories are not currently eligible for ENERGY STAR® certification. Design these buildings to beat Title 24 by 15% and take advantage of free diagnostic testing by PG&E.

Description

ENERGY STAR® is a joint program of the U.S. Environmental Protection Agency (EPA) and the U.S. Department of Energy (DOE). It is a voluntary program that strives to reduce greenhouse gas emissions through energy efficiency.



ENERGY STAR® certification is given to homes designed and tested to perform 15% better than Title 24. To participate in PG&E’s ENERGY STAR® New Homes program, homes in the Bay Area must receive a third-party Home Energy Rating System (HERS) verification. HERS verification can be obtained through two providers recognized by the California Energy Commission (see Resources below).

During a HERS home inspection, the rater will:

- » Perform construction and plan reviews
- » Check duct sealing with a duct-blaster test

- » Test for envelope sealing/reduced infiltration through a blower-door test
- » Verify ACCA Manual-D duct design
- » Verify refrigerant charge and airflow measurement or thermostatic expansion valves (TXV) on split system cooling equipment

Multifamily housing projects that meet the ENERGY STAR® certification criteria are eligible for additional funding to help offset the HERS rating costs and increased efficiency measures.

Benefits

The primary benefit is reduced utility costs and increased comfort. Another benefit is higher quality construction, a result of exceeding minimum construction standards with air sealing, increased insulation and high efficiency equipment.

Other benefits include reduced greenhouse gas emissions, a result of using more efficient, smaller heating and cooling equipment, and saving natural resources through advanced framing.

Benefits to the builder/developer include improved resident/owner satisfaction, higher construction quality control, and ENERGY STAR® marketing tools and co-promotional advertising opportunities.

Application



ENERGY STAR® is applicable only to low-rise (three habitable stories or less) multifamily buildings. *Buildings must be individually metered to receive PG&E incentives for HERS testing.*

There is currently no ENERGY STAR® designation for high-rise residential buildings.

Design Details

ENERGY STAR® certification efforts generally focus on five categories of building energy efficiency:

| CATEGORY | ACWMA GUIDELINES MEASURE # |
|--|---|
| Reduced air infiltration | Systems 10 - Advanced Ventilation Practices |
| Tight ducts | Systems 09 - Duct Effectiveness |
| Improved insulation | Structure 09 - Insulation Structure 05 - Advanced Framing Design |
| Energy-efficient windows | Structure 13 - High-Performance Windows |
| Energy-efficient heating and cooling equipment | Systems 03 - High-Efficiency Heating Systems 07 - Avoid Air Conditioning Systems 08 - High-Efficiency Air Conditioner |

Integrated Design

The design team can make ENERGY STAR® certification a central part of the green building strategy by utilizing an integrated design approach. This can increase energy efficiency while simultaneously reducing costs for individual measures. Suggestions include:

- » Orient buildings properly to maximize solar gain and natural ventilation (*Planning & Design: Measure 03—Building Placement and Orientation*).
- » Limit windows on the east and west walls to cut morning and afternoon heat gain in summer, and reduce heat loss in winter (*Systems: Measure 01—Passive Solar Heating and SY12—Daylighting*).
- » Use advanced framing techniques that place studs 24-inches on-center and give greater insulation values to the wall assemblies (*Structure: Measure 05—Advanced Framing Design*).
- » Specify sealed combustion furnaces with high efficiencies that improve indoor air quality (*Systems: Measure 03—High-Efficiency Heating*).
- » Include non-ozone depleting refrigerants in high SEER cooling equipment (*Systems: Measure 08—High-Efficiency Air Conditioner with Advanced Refrigerant*).
- » Downsize onsite energy generation needs (photovoltaics, microturbines, solar hot water heating, etc.) by improving insulation, equipment efficiencies, lighting and more (*Systems: Measure 15—Onsite Electricity Generation*).

Code Considerations

ENERGY STAR® certification is based on achieving a level of efficiency above code requirements. In California, buildings three stories and under fall within the residential version of Title 24.

Buildings four stories and taller fall within Title 24's commercial/high-rise residential building requirements, and are not eligible for ENERGY STAR® designation.

In 2005 the Title 24 energy standards will be revised to include higher levels of energy efficiency. The impact on ENERGY STAR® ratings under the 2005 standards is not yet determined.

Considerations for Residents

People living in an ENERGY STAR® home will benefit from increased comfort and lower energy costs. Heating and cooling of the rooms will be more uniform. High-performance windows will keep heat out in summer, while duct sealing and ventilation strategies will help maintain good indoor air quality.

Cost and Cost Effectiveness

| | | |
|----------------|--------|---|
| BENEFIT | ★★★ | ENERGY STAR®-certified homes have tighter building envelopes, reducing the need for heating and cooling, and thus reducing operating costs. |
| COST | \$\$\$ | |

To ensure that systems interact properly, some review and consulting in passive solar design and energy simulation will probably be necessary. This should be part of an integrated design process to maximize benefits and reduce first costs.

The cost of a HERS rating varies according to whether the rater performs visual inspections or diagnostic testing. For the ENERGY STAR® program, one model in each building *must* be tested; subsequently, one-in-seven sampling is possible. Ratings done using the sampling method cost about \$150 per unit. However, if tight ducts or TXVs on air conditioners are used for Title 24 or ENERGY STAR® compliance, then all units must be verified, increasing costs.

For multifamily projects in PG&E territory that meet ENERGY STAR® criteria, the following incentives are available to help offset consulting and diagnostic costs (check with PG&E for program changes):

Low-Rise (3 stories and under)

Builder: \$50/unit (up to \$6,000) for HERS inspection, Architect or Title 24 Consultant: \$40/unit (up to \$5,000).

High-Rise (4+ stories)

No cash incentives. Inspections are available free of charge.

Resources

- » **ENERGY STAR® Homes:** Tel. (888) STAR-YES
www.energystar.gov/homes
- » **California Title 24 Building Energy Efficiency Standards:** www.energy.ca.gov/title24/index.html
- » **PG&E ENERGY STAR® Homes** (for diagnostic testing and program changes): Tel. (800) 342-7737
email: newhomes@pge.com
www.pge.com/res/energy_tools_resources/efficient_new_homes/info_for_builders
- » **PG&E multifamily energy efficiency training classes:**
www.designingforefficiency.com
- » **California Multifamily Housing Consortium:**
www.seiinc.org/mfconsortium.html
- » **HERS providers** recognized by the California Energy Commission:

California Home Energy Efficiency Rating System (CHEERS), tel. (800) 424-3377, www.CHEERS.org

Certified Energy Rating & Testing Services (CALCERTS), tel. (916) 987-9444, www.CALCERTS.com

MOISTURE SHEDDING AND MOLD AVOIDANCE

Avoid Moisture and Mold Problems

| WHO | KEY BENEFITS |
|---|---|
| <ul style="list-style-type: none"> ✓ Developer/PM ✓ Funder Policymaker ✓ Architect ✓ Builder Resident Building Manager | <ul style="list-style-type: none"> ✓ Health/IEQ Site Protection Energy Efficiency Water Efficiency Material Efficiency ✓ O&M ✓ Resident Satisfaction ENERGY STAR® |

DIVISION 7: Thermal Moisture and Protection

Recommendation

Take precautions to prevent the intrusion of moisture through the exterior envelope and to thoroughly exhaust moisture from bathrooms and kitchens.

Description

Install drainage planes on all wall surfaces, with flex wrap around all windows and doors. Help ensure that moisture drains away from building elements by properly shingle-flashing all windows, doors and joints.

Provide sufficient ventilation in kitchens and baths.

Benefits

Most major building failures and construction defect lawsuits are related to water intrusion into the building's walls, ceilings and floors. Water intrusion can lead to rot, mold and mildew, and may eventually result in structural and health problems. Most of these problems can be avoided by taking the appropriate measures during design and construction.

Application

All buildings.

Design Details



It is prudent to have a waterproofing consultant review all flashing, waterproofing, roofing, and door/window sill details. The consulting fees will be a fraction of the cost of remediation if one improperly designed or installed detail allows water infiltration. The construction documents can specify that the contractor will hire a consultant and notify the owner/architect of any details that require additional review. Most contractors are willing to do this, since it can reduce their potential liability for water infiltration problems.

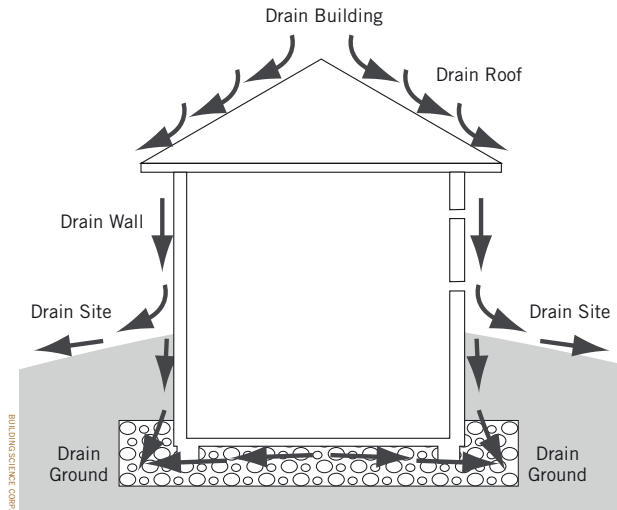

To help prevent rot and mold, design and construct the building so that moisture drains away from building elements.

SIDING AND FLASHING

» Be vigilant during construction to ensure that there is an appropriate moisture drainage plane behind the siding and over the sheathing. This may be accomplished in a variety of ways depending on siding type. Typically, OSB sheathing is covered with a house wrap or felt paper.

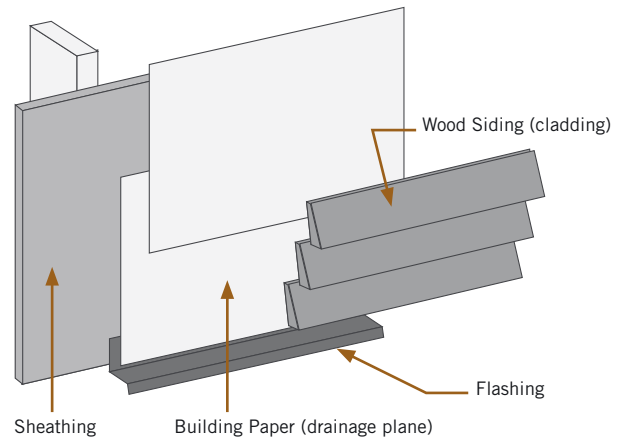

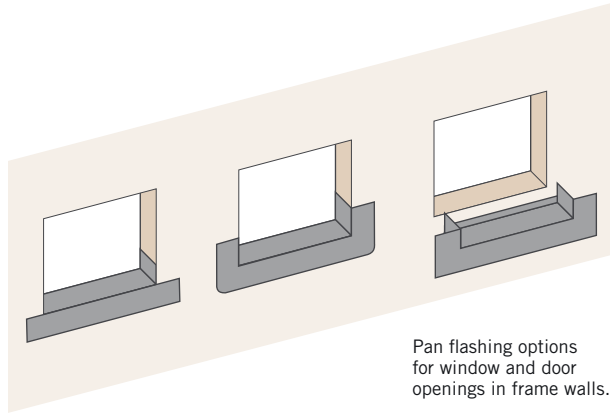

Pan flashing options for window and door openings in frame walls.

- » Take special care with windows and doors to ensure that moisture behind the siding runs over the window flashing and drains to the exterior.

ROOF AND EAVES

- » Extend the eaves at least 2 feet over walls to reduce the intrusion of water on the walls, windows, doors, and at the wall-eave intersection.
- » Design roof surfaces with a positive slope and shed water through gutters and downspouts away from the building at grade.

EXHAUST FANS

- » If fans are loud, residents may not use them or may even disconnect them. In bathrooms, install exhaust fans vented to the outdoors with low speed motors to reduce noise nuisance (look for ENERGY STAR®-labeled exhaust fans). Exhaust fans should be connected to moisture sensors (humidistat) so that they operate whenever moisture reaches a certain threshold. With quiet fans, residents will barely notice this technology (for more on mechanical ventilation, see Systems: Measure 10—Advanced Ventilation Practices).
- » Exhaust kitchen hoods to the outside, not the attic. Kitchens produce a lot of moisture that can be detrimental if not properly ventilated. In high-rise buildings, this can be an expensive upgrade because it may require a 1-hour fire rated shaft to be run vertically through the building.

Code Considerations

Designing for moisture shedding is standard practice; making sure it gets done properly requires diligence and some upfront design time.

Considerations for Residents

Water intrusion is one of the main causes of mold in buildings. Many forms of mold are not harmful, but some are toxic to people, especially small children. The best way to ease concern about mold is to avoid creating conditions where it can grow.

To avoid costly repairs and potential health problems, instruct occupants to look for early signs of mold or rot, and to immediately report water marks on drywall and plumbing problems.

Cost and Cost Effectiveness

| | | |
|----------------|----------|---|
| BENEFIT | ★★★ | Most moisture shedding and mold avoidance techniques are low or no cost; they merely require proper detail specifications by the architect and attention to detail by the builder during construction. Proper care during construction is much more cost effective than having to remove roof or wall assemblies to fix moisture problems like mold or rot. |
| COST | \$ \$ \$ | |

Humidistat controls on fans cost about \$100 each installed. Low speed (premium motor) fans cost approximately \$70 to \$100 more than standard fans.

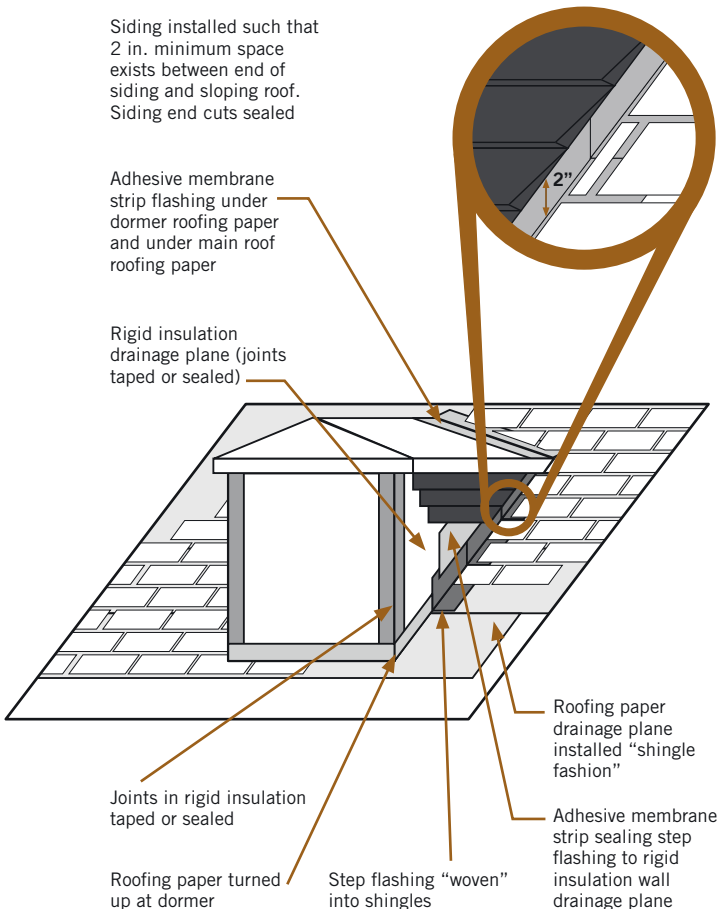

Resources

- » **Energy and Environmental Building Association** publishes the *Moisture Control Handbook*. Their website also has articles about water management: www.EEBA.org
- » **Tyvek** has an online window installation guide and house wrap information: www.tyvek.com
- » **Building Science Corp.** offers detailed articles on moisture and drainage plane issues: www.buildingscience.com
- » **U.S. EPA** has a website that addresses moisture control in buildings. It focuses on schools but has applicable information for multifamily housing: www.epa.gov/iaq/schooldesign/moisturecontrol.html
- » **ACWMA's** Materials Database lists products that correspond with this measure: www.multifamilygreen.org

RECYCLING COLLECTION

Make it Convenient for Residents to Recycle

| WHO | KEY BENEFITS |
|--|--|
| <ul style="list-style-type: none"> ✓ Developer/PM Funder Policymaker ✓ Architect Builder ✓ Resident ✓ Building Manager | <ul style="list-style-type: none"> Health/IEQ Site/Community Energy Efficiency Water Efficiency ✓ Material Efficiency ✓ O&M ✓ Resident Satisfaction ENERGY STAR® |
| <p>02870: Site and Street Furnishings</p> | |

Recommendation

Provide convenient facilities for recycling collection within each unit and easy access to the building’s central recycling bins. Make recycling and garbage services equally easy to use.

Food waste recycling is new in many California municipalities. Design multifamily buildings to accommodate food waste recycling in the future.

Description

Recycling should be as easy as throwing out garbage, but multifamily housing is rarely designed to facilitate this. Long walks to bins or poorly designed collection areas are common barriers to recycling. Residents may be unaware of recycling opportunities because they have little or no contact with the waste company. Often, the waste bill is paid directly by the property manager. Frequent tenant changes can make outreach a challenge. Thus, proper design of collection areas is critical to making recycling easy, sanitary and useful for residents.

Benefits

Recycling reduces the amount of material entering landfills and can save money for building owners through reduced disposal fees.

Application

All multifamily developments.

Design Details

Most residents prefer to recycle if it is easy. Design recycling infrastructure to include mixed paper, cardboard, containers (metal, glass, plastic) and possibly food waste and other organic material. Use simple and clear signage. Recycling bins should be distinct from garbage bins.

SIZE OF CONTAINERS & ENCLOSURES

Garbage and recycling companies will provide carts, bins or both. The size and number of containers depend on the number of people or units in the project and the frequency of collection.

- » For once-a-week collection (the norm), a rule of thumb is to provide ¼ cubic yard of capacity for every three residents. This can be a mix of garbage bins and recycling carts or bins, with about half the volume for garbage and half for recycling.
- » Bin sizes vary, but the typical footprint is 7-feet wide and 4-feet deep. Most 64-gallon carts fit in a footprint that is 32x30 inches and 42-inches tall. Bins and carts typically have hinged lids that must be raised. Take care when designing spaces for bins and carts since they can damage low ceilings. Space is also needed to walk among the containers and shift them around. An area that is 150% of the sum of bin and cart footprints should suffice.

OUTSIDE THE BUILDING

Locate recycling containers near garbage bins so residents can make one trip to dispose of recyclables and trash. Work with the city and the waste hauler/recycler to verify that enclosures are accessible to their trucks. Considerations include:

- » Locating containers beneath buildings, which is often done where underground parking is available, can pose serious difficulties for the collection company.
- » Some trucks need a 40-foot minimum turning radius and 20 feet of vertical clearance to empty a bin.
- » Driveways that slope down to the garage make it difficult to handle containers, requiring drivers to roll out containers, and increasing the risk of injury or property damage. Many haulers charge substantial extra fees in these situations.

In complexes with exterior parking lots, the typical practice is to provide walled enclosures for bins and carts. A well-designed enclosure will have:

- » Sufficient turning radius and vertical clearance to empty a bin;
- » Sufficient space to move among bins and carts;
- » Lever-style door handles that can be operated with full hands;
- » Wall space for instructional signage;
- » Smooth floor that can be swept or mopped;
- » Wheel stops near walls to prevent damage to walls;
- » Adequate lighting to read signs and sort materials;
- » Properly enclosed or sealed containers to limit pests and theft; and
- » Located so that noise, odors and truck exhaust won't be a nuisance to residents.



Providing accessible space for recycling collection will encourage use.

INSIDE THE BUILDING AND UNITS

In all areas where residents will be emptying recyclables and trash, provide durable and easily cleanable surfaces, and keep the areas well-maintained. Dirty or unsightly recycling and trash collection stations discourage people from using them and attract vermin.

- » **Collection inside the units.** Try to provide a single disposal area for garbage and recyclables inside each residential unit. Provide at least one 18-inch bin for recycling, and preferably one bin for each type of recyclable material. Locate bins in an accessible place but shield them from view so they are not an eyesore.
- » **Kitchen storage.** Small kitchens require creative storage solutions such as drawers, tilt-out bins, or pull-out shelves. Some bins have lids that close automatically when a cabinet door is closed. Corner

cabinets and under-sink storage are good solutions because these are often underused spaces. Consider offsetting sink plumbing so there is more storage room under sinks. For corner cabinets, a spinning rack can be space efficient. Label or color-code bins, especially if they are not easily visible.

- » **Chutes.** Developments of three or more stories often use chutes to convey garbage from each floor to a ground-floor trash room, where it lands in a metal bin. Chutes keep stairwells and elevators cleaner. The bins in the trash room are either wheeled to a pick-up point by maintenance staff or rolled to the collection truck by the driver. Spills in the collection rooms and near the chutes are inevitable, so use durable, easy-to-clean wall and floor finishes in these areas.

The best way to maximize recycling in this situation is to provide a separate chute for recyclables. Locate the trash and recycling chutes side by side for equal accessibility. Clearly mark the recycling chute, "Recycling Only." In jurisdictions with single-stream recycling, all recyclables may be mixed together and easily handled with a single chute. In jurisdictions that require recyclables such as paper and plastic to be separated, the number of chutes may become unwieldy. One solution is a carousel system such as that sold by Wilkinson Hi-Rise (www.hiri.com).

Consider installing sound installation so that the chutes are not a nuisance. Chutes should be as straight as possible to reduce the chance that waste will get stuck in a bend.

MAIL ROOMS, LAUNDRY ROOMS AND OTHER COMMON AREAS

It is important to have recycling and garbage containers in common areas, such as the mail room and laundry room. To prevent identify theft, recycling in mail areas should ideally be behind a wall with a slot for access. In laundry areas, large plastic detergent bottles and cardboard boxes require space for large carts (96-gallon) or a way for maintenance staff to keep empty carts nearby for exchange.

BULKY WASTE

As tenants of multifamily buildings move in and out, they often create a large volume of bulky waste, such as cardboard and discarded furniture. Provide information to new and departing tenants about how to recycle waste. Designate an area for cardboard recycling, and provide tenants with a list of local material drop-off facilities and stores that accept donations of household goods.

COMMUNITY ACTIVITIES

Consider collecting bottles and cans that have redemption value to fund community activities.

COMPOST

In the future, waste haulers will likely offer curbside food waste composting service, but it is currently only offered in a few cities. Plan ahead and include space for a separate food waste compost bin in the garbage and recycling enclosure. For the greatest convenience, consider designing kitchen counters with a lidded chute for compost collection.

Community gardens are a good place to actively encourage composting. Building projects in Alameda County can contact ACWMA for special pricing on compost bins.

Code Considerations

In California, state regulations require cities to divert 50% of waste from the landfill. In Alameda County, Measure D sets a higher standard, calling for 75% waste reduction by 2010.

Local policies and regulations may suggest or require that property owners provide space for tenants to recycle. Check local requirements to determine design implications. Some cities have ordinances about enclosing or reducing the visibility of garbage and recycling containers.

Considerations for Residents

A well-organized recycling program can improve residents' attitudes toward recycling. It's important to provide instruction to residents and staff on proper recycling procedures. Composting in a community garden fosters social interaction.

Cost and Cost Effectiveness

| | | |
|----------------|--------|---|
| BENEFIT | ★★★ | Recycling can save money for building owners. In many jurisdictions, it is less costly to recycle than to dispose of waste as trash. By providing well-planned space for recycling, the owner can enable tenants to keep disposal costs down. |
| COST | \$\$\$ | |

Chute systems add cost, but increase participation in high-rise buildings.

Resources

- » **ACWMA** provides information on recycling, composting, and more. Search the Materials Database for product information:
www.multifamilygreen.org
(510) 614-1699
- » **California Integrated Waste Management Board** has statewide resources on recycling and composting:
www.ciwmb.ca.gov

RECYCLED PRODUCTS

Close the Loop by Specifying Recycled Products

| WHO | KEY BENEFITS |
|---------------------------------------|---|
| Developer/PM Funder Policymaker | Health/IEQ Site/Community Energy Efficiency Water Efficiency |
| ✓ Architect | ✓ Material Efficiency |
| ✓ Builder | O&M |
| Resident | Resident Satisfaction |
| ✓ Building Manager | ENERGY STAR® |

01600: Product Requirements

Recommendation

Specify products containing the highest available percentage of recycled material. Look for the highest postconsumer content possible.

Description

Recycled-content products are increasingly common in the construction industry. Examples include rebar, steel beams and studs, concrete aggregate, carpet, rubber flooring, particleboard and MDF, drywall, countertops and insulation. There are two types of recycled content, post-industrial (also called preconsumer), and postconsumer:

- » **Post-industrial/preconsumer waste.** Many manufacturers use waste from industrial processes to make new products. For example, sawdust from lumber mills is used as a feedstock for other building products, such as MDF, HDF or particleboard. Reusing manufacturing waste often costs less than using virgin materials, and it makes good financial sense for most manufacturers. Specifying products with post-industrial recycled content typically does not help reduce waste going to landfills or help maintain municipal recycling programs. For these reasons, specify products with post-industrial recycled content only if postconsumer content is not available.
- » **Postconsumer waste** is material recovered after a product's useful life has ended and the product is ready to be discarded. Recovery is typically done through curbside collection programs. Materials are then refined into feedstock for new products.

Benefits

Buying products with postconsumer recycled content helps the environment by reducing the need to extract and harvest raw materials and by reducing landfill deposits. Products made with recycled content sometimes provide superior performance compared to virgin products; benefits may include greater durability, less maintenance and reduced cost.

Application

CONSTRUCTION MATERIALS

The following table lists construction products that are commonly available with recycled content. Typical and highest achievable percentages of recycled content are shown.

| CONSTRUCTION MATERIAL | COMMON RECYCLED % | HIGHEST ACHIEVABLE % |
|---------------------------------|-----------------------------|-----------------------------|
| Recycled aggregate | 25 PC | >90 PC |
| Flyash in concrete | 15 PI | 60 PI |
| Rubber flooring | 65 PC | 90 PC |
| Carpet – commercial | 50 PC backing 25 PC face | 90 PC backing 25 PC face |
| Carpet – residential | 50 PC face | 90 PC face |
| Ceramic tile | 25 PC | 55 PC |
| Steel framing | 25 PC | 60 PC |
| Insulation – fiberglass | 25 PI | >25 PC |
| Insulation – cellulose | 90 PI (paper) | 90 PC (paper) |
| Paint | 50 PC | 75 PC |
| Bathroom partitions | 20 PI | 75 PC |
| Wood fiber products (MDF, etc.) | 85 PI | 85 PC |

PI = post-industrial; PC = postconsumer

FURNISHINGS AND MAINTENANCE PRODUCTS

Continue to buy recycled products after the project is occupied. Encourage tenants and maintenance staff to purchase recycled paper towels, garbage bags and outdoor furniture, for example. Include information on products with high postconsumer recycled content in manuals and trainings (*Operations & Maintenance: Measure 01*) and in educational signage (*Operations & Maintenance: Measure 02*).

Design Details

- » Include language in specifications requiring specific recycled-content levels for products. When possible, provide product names and contact information.
- » Specify products that contain high postconsumer recycled content.
- » Give preference to those products that can also be recycled or reused at the end of their useful life.
- » Obtain samples and test their performance. Any product—recycled or not—that has to be replaced often or performs poorly does not benefit the project or the environment.



For more information on recycled products, go to ACWMA's website, which has Environmental Purchasing Program guidelines and links to other resources (www.multifamilygreen.org).



Plastic composite lumber made from recycled plastic and wood pulp functions as trim detail at the El Paseo Studios development in San Jose.

Code Considerations

Alameda County passed ballot Measure D that sets a goal of 75% waste reduction from 1990 levels by 2010. Recycling and purchasing recycled products helps meet that goal by increasing the market for recycled products.

Considerations for Residents

In general, residents won't be able to distinguish recycled-content products from products made with virgin materials.

Check all products for potential odors, air emissions, and maintenance needs to avoid indoor air quality problems. Some products, like recycled rubber flooring, may emit unpleasant odors (*for a discussion of product emissions standards, see Finishes & Furnishings: Measure 05—Carpeting*).

Cost and Cost Effectiveness

| | | |
|---------|--------|--|
| BENEFIT | ★★★ | Most recycled-content products are competitive with or less expensive than comparable virgin products. However, some recycled-content products cost more. These are typically high-end finish materials, such as recycled glass tile, which usually costs considerably more than ordinary ceramic tile. Mainstream products such as insulation and carpeting have very little or no cost difference. |
| COST | \$\$\$ | |

To reduce or avoid disposal costs in the long-term, choose products that the manufacturer will take back at the end of the product's life (*ceiling tile and carpet are two examples, see Finishes & Furnishings: Measure 05—Carpeting*). Also consider donating scraps or extra material (*Finishes & Furnishings: Measure 08—Reclaimed Materials*).

Resources

- » **ACWMA** provides information about buying recycled products. Search the Materials Database for product information: www.multifamilygreen.org
- » **California Integrated Waste Management Board** has a searchable database of recycled-content products: Tel. (916) 341-6606 www.ciwmb.ca.gov/rcp
- » **State Agency Buy Recycled Campaign (SABRC)**: www.ciwmb.ca.gov/BuyRecycled/StateAgency
- » **LEED Reference Guide** has information on how to calculate the amount of recycled materials in your project: www.usgbc.org
- » **Green Spec**, an online product directory published by Building Green, lists building products with recycled content: www.greenspec.com
- » **Oikos** lists products with green building attributes, including recycled content: www.oikos.com

ADAPTABLE BUILDINGS

Design for Accessibility and Future Changes in Technology and Building Use

| WHO | KEY BENEFITS |
|---|--|
| <ul style="list-style-type: none"> ✓ Developer/PM ✓ Funder ✓ Policymaker ✓ Architect ✓ Builder ✓ Resident ✓ Building Manager | <ul style="list-style-type: none"> ✓ Health/IEQ ✓ Site/Community ✓ Energy Efficiency ✓ Water Efficiency ✓ Material Efficiency ✓ O&M ✓ Resident Satisfaction ENERGY STAR® |
| <p>DIVISION 1: General Requirements</p> | |

Recommendation

Build so that access for disabled people may be expanded and improved in the future.

Design for technology upgrades with convenient cable pulls and electrical capacity.

Design for flexibility, and consider making ground-floor space adaptable for multiple uses.

Description

Multifamily buildings accommodate people with a diverse range of needs, including aging or disabled (permanent or temporarily) residents. Also, over the course of a building's life, residents' needs may change. And in mixed-use buildings, the need for retail or other commercial space may change over time.

It can be costly to renovate a building to accommodate changing needs. Waste can be minimized, and money saved, if buildings are designed with future adaptation in mind. Future changes can be simpler and more cost effective when planned for early in the design process.

Benefits

Designing for future adaptability will reduce costs significantly when changes or renovations become necessary. Adaptive design also minimizes waste associated with occupant or technology changes. Finally, it can increase a building's longevity.

Application

Useful for all new developments, especially those without long-term restrictions on occupancy, or those in urban environments where use is more likely to change over time.

Design Details

UNIVERSAL DESIGN

Universal design incorporates a range of accessibility features, from easy-to-use door handles to adequate lighting to elevators compliant with the Americans with Disabilities Act (ADA). It is not strictly limited to designing for the elderly or disabled; instead it focuses on providing increased accessibility for all occupants.

Universal design strategies were incorporated in the Carmen Avenue affordable housing project in Livermore, California (see the case study in these Guidelines). The architects designed roughly 50% of the development to be fully wheelchair accessible. The other half was designed with adequate door clearances, low thresholds, and elevator access so that disabled people could visit any unit with relative ease. This will allow future development, if needed, to be fully ADA accessible for a reasonable investment.

Strategies for flexible accessibility include:

- » Minimize the number of hallways and structural walls inside units so they can be easily altered.
- » Place a bedroom and bathroom on the lower floor of multistory units.
- » Allow for the possibility of creating a 60-inch turning radius in bathrooms, kitchens and small areas: make an adjacent wall nonstructural or create a storage area in an adjacent space that could later be adapted for a wheelchair turnaround.
- » Provide blocking in bathroom walls to accommodate grab bars in the future.
- » Design roll-in showers to provide easy access for people in wheelchairs.



Ample storage and an open floor plan allow for flexible use of this studio unit.

ADAPTIVE DESIGN

Adaptive design refers to designing a building so that as it ages, it can readily accommodate technology upgrades, changes in use, and other modifications that may or may not be foreseen. Significant alterations might include additions to projects, such as a second phase of construction or additional units. In cases where future development on the site may occur, consider clustering buildings and focus on building upward instead of outward. Building up rather than out saves energy and building materials; it also reduces the initial development footprint, which may allow for future expansion (for more about site design considerations, see *Planning & Design: Measure 03—Building Placement and Orientation*).

If a project includes retail or commercial space, anticipate that the use may change. Keep floor plans open, and eliminate awkward spaces that could not readily be converted to residential use later. Also, consider the reverse: Residential units may eventually be converted to commercial use.

In all adaptive designs, the ability to preserve finishes whenever possible is desirable. Selecting durable, detachable, long-lasting materials will reduce waste and replacement costs.

Dimensional planning is one way to keep options open for future build-out and expansion. Buildings that are constructed on 2- or 4-foot modules can be more easily adapted, with less waste from demolition and reinforcement.

While it is not usually an option, sometimes preserving an open portion of a site, in lieu of complete build-out now, can aid future expansion. Consider clustering and stacking units to leave a portion of the site available for later infill.

DESIGN FOR TECHNOLOGY UPGRADES

As communication technology changes, it's likely that cabling and wiring systems will need to be upgraded. Integrating data cables, LAN wires and fiber optics throughout the spaces will help meet future needs, even if not used currently. Adding sufficient power outlets and telephone jacks will further allow for technological advances.

Some green building features may not be financially viable on a particular project today, but can be planned for to make it more cost effective to add them later. For example:

- » **Pre-wire for photovoltaics.** Run conduit to the roof. Leave space in a mechanical room for inverters and other equipment.
- » **Pre-plumb for solar hot water.** Run pipes to a potential hot water storage location.

Code Considerations

Consider possible scenarios that could affect occupancy or space usage in the near future, including periodic city or county general plan amendments and local housing regulations. Also, look at zoning population projections, planned residential development and other demographic indicators that identify future growth patterns, before deciding on future adaptation goals.

The Americans with Disabilities Act guides accessibility design for all developments. Extending ADA design strategies to more areas than required does not affect code compliance.

Other strategies mentioned in this measure should not affect code compliance.

Considerations for Residents

Residents will be able to update their homes with new technology. Perhaps most importantly, accessibility features may allow them to stay in their homes longer than might be otherwise possible. Residents with temporary injuries also benefit from accessibility features. And features such as wider door clearance make life a little easier for everyone.

Cost and Cost Effectiveness

| | | |
|----------------|--------|---|
| BENEFIT | ★★★ | Planning for future adaptation at the beginning of a project is an investment with long-term savings and quality-of-life benefits. Upfront costs may be incurred for additional design time, accessibility consultants, and changes in materials, handles, fixtures and wiring. |
| COST | \$\$\$ | |

Resources

- » **North Carolina State University's** Center for Universal Design has many useful features for adaptable housing: www.design.ncsu.edu/cud
- » **AARP** has information on universal design: www.aarp.org/universalhome
- » **Trace Center College of Engineering** at the University of Wisconsin–Madison has compiled universal design guidelines: www.tracecenter.org/world/gen_ud.html
- » **Home Energy Magazine Online** has an article on clustering homes: “Design Secrets for Affordable Efficiency” (Jan/Feb 2000): www.homeenergy.org

The sitework measures in this section are designed to:

- » Protect the health of construction workers and future residents
- » Reduce waste
- » Prevent pollution of air, soil and waterways

Some of the issues covered in this section are regulated by state and local government agencies. ACWMA's recommended measures go beyond existing regulations to offer practical, proven suggestions for best management practices that will contribute to a healthy and productive jobsite. Some of these recommendations are basic good housekeeping procedures that promote safe, efficient work habits, such as using proper procedures to clean up spills. Even if

SITWORK

these procedures seem like commonsense, it's important to have clear policies and to train subcontractors and hold them accountable for following best practices.

The three R's—reduce, reuse and recycle—are at the heart of a number of these sitework measures. Reducing the amount of hazardous and nonhazardous waste at a jobsite is a key step toward protecting public health and the environment. It also saves money. Reuse and recycling are also both environmentally and economically sound practices: On a project where the builder makes an effort to manage waste, up to 80% of construction and demolition debris can be diverted from landfills. Much of this material can be put to good use—either reused on site, recycled or donated.

The recommended practices in this section are good for people's health, good for the environment, and good for business. Safer, healthier jobsites mean increased productivity and reduced liability. Healthier buildings may also result in fewer callbacks after occupancy.



BENEFITS

This table lists the Guidelines' Sitework measures and their primary benefits (see the individual measures for details).

| MEASURE | BENEFITS | Health/IEQ | Site/Community | Energy Efficiency | Water Efficiency | Material Efficiency | O&M | Resident Satisfaction | ENERGY STAR® |
|--|-------------------------|---|----------------|-------------------|---|---------------------|-----|-----------------------|--------------|
| 01 C&D waste management | | | ✓ | | | ✓ | | | |
| 02 Efficient use of construction materials | | | | | | ✓ | | | |
| 03 Construction IAQ management | ✓ | ✓ | | | | | ✓ | ✓ | |
| 04 Hazardous materials and waste | ✓ | ✓ | | | | ✓ | ✓ | ✓ | |
| | EXPLANATION OF BENEFITS | <p>Health/IEQ: Reduces indoor pollutants, promotes better indoor environmental quality, and/or provides opportunities for improved public health.</p> <p>Site/Community: Protects land, water and air on and near site from pollution or other environmental damage, uses municipal infrastructure more efficiently by redeveloping building or site, and/or provides important and needed amenities for the surrounding community.</p> <p>Energy Efficiency: Reduces building energy consumption.</p> <p>Water Efficiency: Reduces water use in building and/or on site.</p> | | | <p>Material Efficiency: Reduces, reuses and/or recycles materials that might have otherwise ended up in landfills, reduces materials needed to construct or operate the building, and/or uses materials produced in a way that minimizes environmental damage.</p> <p>O&M: Increases building's durability, and/or reduces operating and maintenance expenses.</p> <p>Resident Satisfaction: Saves residents money and/or improves residents' quality of life.</p> <p>ENERGY STAR®: Helps achieve ENERGY STAR® for Homes certification.</p> | | | | |

KEY CONSIDERATIONS

CODES

Many jurisdictions in Alameda County and throughout California require a minimum of 50% construction and demolition (C&D) waste recycling, and some city and county ordinances mandate that a C&D Waste Management Plan be approved prior to obtaining building and demolition permits. The California Integrated Waste Management Board has also adopted a model ordinance that requires a range of diversion rates from 50% to 75%.

With trends in the Bay Area and other regions toward tighter control of waste and pollution, it is likely that these regulations will remain in force or even become more stringent in the future. Following ACWMA's recommended practices will help developers and builders stay ahead of the regulatory curve. It can also help enhance their reputation among stakeholders, including funders, building officials, subcontractors, workers and residents.

BAY AREA RESOURCES

ACWMA provides extensive information about C&D waste management. Resources include a model waste management ordinance, and a specification Section 01505 and waste management plan for recycling C&D debris. ACWMA also publishes the "Builder's Guide to Reuse and Recycling: A Directory for Construction and Demolition Materials." To obtain these publications, call (510) 614-1699 or go to www.multifamilygreen.org.

SCHEDULING

Some of these sitework measures require particular attention to scheduling. For example, a construction IAQ management plan (*Sitework: Measure 03*), spells out appropriate strategies for minimizing construction-related IAQ problems. The plan will often specify that porous materials like carpet and furniture should only be installed after finish materials such as paints and sealants have cured, and that carpeting and furniture be aired out before installation. The plan may also require the contractor to schedule a pre-occupancy flush-out of the building's interior to reduce the potential for post-occupancy IAQ problems.



Concrete from construction and demolition practices is crushed and turned into recycled aggregate.

SPECIFICATIONS AND CONTRACT DOCUMENTS

In the Bidder's section of the project summary, include the required diversion levels of construction and demolition (C&D) waste. Also, include language in the specification Section 01505 requiring C&D diversion. Contract documents should specifically state the role of each party in the construction waste management and construction indoor air quality (IAQ) management plans, from architect to subcontractor. The documents should clearly hold a responsible party accountable for failure to meet waste management and pollution prevention goals (*see the individual measures in this section for details*).

COST

Some of these procedures may increase costs initially but save money over the life of the building. An IAQ management plan (*Sitework: Measure 03*), for example, will likely result in additional labor and time to develop and implement, but if it is well executed it may result in fewer call backs, and may extend the life of the HVAC system. Training staff on procedures for handling, use and cleanup of hazardous materials (*Sitework: Measure 04*) can add time but will reduce potential liability. Some alternative, low-toxic materials cost more initially than standard products but result in lower disposal costs and a healthier jobsite and home.

Other practices add little or no extra cost. Creating cut-piles for efficient material use (*Sitework: Measure 02*), for instance, requires minimal training and labor, yet offers significant savings in material costs and dramatically reduces landfill fees. With the availability of mixed C&D recycling facilities in the Bay Area, implementing a C&D waste management plan (*Sitework: Measure 01*) requires no more labor than standard industry practice.

ROLES AND RESPONSIBILITIES

- » **Policymaker and code official.** Adopt a C&D Waste Management ordinance in your community (see the Code Considerations section of Sitework: Measure 01).
- » **Developer and project manager.** In bidding and construction documents, clearly define requirements, roles, responsibilities and accountability. Project meetings should include regular discussions about waste management and IAQ goals and progress, and should include all relevant parties, including subcontractors.
- » **Architect.** Some developers will use an architect to draft the construction IAQ management plan (Sitework: Measure 03). Architects should be familiar with materials that reduce IAQ problems, such as low-VOC products. They should also list products that have potential for causing problems, and offer control measures for handling those materials. The architect should call out requirements that might affect scheduling, such as requiring salvaging or deconstruction (Sitework: Measure 01 / Also see the Specifications and Contract Documents considerations above).
- » **Builder.** The builder is the primary party accountable for carrying out the sitework measures. Responsibilities include tracking and documenting quantities of waste produced and diverted; developing methods of recycling debris; training personnel; conducting salvaging or deconstruction activities; and implementing an IAQ management plan.



Ends and cut-pieces of joists, siding, framing and other building materials are stockpiled for reuse on this jobsite. Pieces not used are donated or recycled once construction is complete.

FOCUS ON SITework: The Breakers at Bayport Apartments

At the Breakers at Bayport Apartments, a 62-unit community to be built in Alameda by Resources for Community Development (RCD), the architect incorporated ACWMA's model specification 01505 for a construction and demolition waste management plan. The architect and developer reviewed the plan's implications with the contractor. The material recovery facility in nearby San Leandro is currently achieving close to 70% recycling rates from mixed construction debris boxes, so a high level of jobsite recycling should be possible on this project.

To learn more about this project, see the Breakers at Bayport Apartments case study.

C&D WASTE MANAGEMENT

Reduce, Reuse and Recycle Waste Created at the Jobsite

| WHO | KEY BENEFITS |
|---|--|
| <ul style="list-style-type: none"> ✓ Developer/PM ✓ Funder ✓ Policymaker ✓ Architect ✓ Builder Resident Building Manager | <ul style="list-style-type: none"> Health/IEQ ✓ Site/Community Energy Efficiency Water Efficiency ✓ Material Efficiency O&M Resident Satisfaction ENERGY STAR® |

01505: Construction & Demolition Waste Management Plan

Recommendation

Identify the types and estimate quantities of waste generated at the jobsite. Divert at least 50% of the construction and demolition (C&D) debris from landfills by reducing, reusing or recycling waste generated at the jobsite

If possible, exceed this recommendation by diverting at least 60% to 75% of C&D waste from landfills. Where facilities are locally available, divert 100% of asphalt and concrete.

Description

Construction and demolition debris constitute about 21% of the materials in Alameda County’s landfills and about 30% of the waste stream statewide. C&D waste generally consists of wood, drywall, metals, concrete, dirt, insulation, cardboard and more. Much of this waste can be reduced, reused or recycled.

A C&D Waste Management Plan is a crucial component of managing waste during project demolition and construction. The plan should focus on the three R’s: reduce, reuse and recycle.

Benefits

C&D waste management conserves natural resources and slows the rate at which landfills reach capacity. It can also save contractors money by reducing waste of purchased materials and by lowering disposal fees.

Application

Applicable to all new construction, renovation and demolition projects.

Design Details

Project Specifications. Include the required diversion levels in the Bidder’s section of the Project Summary. Also, include language in the specifications section 01505 requiring C&D diversion (*see www.multifamilygreen.org for ACWMA’s Section 01505*). Be sure the contract documents hold a responsible party accountable for failure to meet the waste management goals.



Jobsite recycling bins.

C&D Waste Management Plan. Require the contractor to develop and implement a C&D Waste Management Plan (*see www.multifamilygreen.org for ACWMA’s Section 01505 Model Plan*). This plan will typically require the contractor to:

- » Check bid package and local jurisdiction to determine contract requirements.
- » Include a good-faith estimate of each type of construction waste that would be created if no diversion occurred.

- » Develop means and methods for reusing and recycling debris, usually through separating some types of debris, delivering mixed debris to a mixed C&D recovery facility, or a combination of both. This includes contacting local recycling facilities and haulers to identify required terms and conditions.
- » Train onsite personnel to implement the Waste Management Plan before demolition or construction begins.
- » Furnish copies of the plan to all onsite supervisors, each subcontractor, the owner and the architect.
- » Document the results of the waste management efforts, including the type and amount of waste reused or recycled.

Scheduling and compliance. For C&D waste management to be most effective, the issues must be addressed in Design Documents phase of a project. C&D waste management can disrupt construction sequencing if, for example, a project includes demolition and there are salvageable materials; scheduling should allow for salvaging and deconstruction activities. Require contractors to cover the required Waste Management Plan with subcontractors in pre-construction meetings and to include contract language requiring that all subcontractors comply with the plan. Consider imposing fines or other penalties for failure to comply with the waste management requirements.

Code Considerations

Many jurisdictions in Alameda County and throughout California require a minimum of 50% C&D debris recycling. City and county ordinances often mandate that a C&D Waste Management Plan be submitted and approved prior to obtaining building and demolition permits. ACWMA's model C&D ordinance, as well as a list of cities in Alameda County with C&D ordinances, are available at www.multifamilygreen.org. For code issues outside of Alameda County, check with your building or waste management department.

Considerations for Residents

No effect on occupants.

Cost and Cost Effectiveness

| | | |
|----------------|--------|---|
| BENEFIT | ★★★ | Planned management of C&D waste has been proven to reduce the amount of material delivered to landfills and reduce project costs due to decreased material disposal fees. |
| COST | \$\$\$ | |

Labor costs and jobsite logistics. With the Bay Area's large number of C&D recycling facilities, including mixed recovery facilities, implementing a C&D waste management plan isn't difficult.

If the jobsite allows for multiple bins, most contractors choose to source-separate materials such as concrete, metals and cardboard, since disposal rates are lower for source-separated material and some materials, such as metals, can generate revenue. Some contractors find that separating materials requires additional labor.

Mixed C&D recovery facilities are increasingly the preferred recycling choice, especially if there are space or time constraints at the jobsite, or if the materials are difficult to separate on site, such as demolition materials from tenant improvement projects. Mixed C&D facilities receive, sort and recycle loads of mixed materials from construction or demolition sites if 60% or more of the total load consists of recyclable materials. Recycling rates vary, but most mixed C&D facilities recycle 50% to 70% of the material delivered.

Cost effectiveness of salvaging. Unless the salvaged materials are valuable—such as ornate hardware or stained glass windows—the labor cost of salvaging may exceed the material's market value. In this case, the owner must determine if salvage is worth the extra expense. Nonprofit salvage companies may offer a tax-deductible donation receipt for the value of the salvaged goods to help offset the additional cost.

Resources

- » **ACWMA** provides extensive information about C&D waste management, including a model ordinance, a specification Section 01505 and waste management plan for recycling C&D debris and the *Builders' Guide to Reuse and Recycling, A Directory for Construction and Demolition Materials* (available on website): www.multifamilygreen.org
Tel. (510) 614-1699
- » **California Integrated Waste Management Board** provides information about C&D waste management, including *Designing With Vision: A Technical Manual for Material Choices in Sustainable Construction*: www.ciwmb.ca.gov/ConDemo

EFFICIENT USE OF CONSTRUCTION MATERIALS

Organize Cut-Piles for Lumber, Drywall and Other Scrap

| WHO | KEY BENEFITS |
|---|--|
| <ul style="list-style-type: none"> ✓ Developer/PM Funder Polymaker Architect ✓ Builder Resident Building Manager | <ul style="list-style-type: none"> Health/IEQ Site/Community Energy Efficiency Water Efficiency ✓ Material Efficiency O&M Resident Satisfaction ENERGY STAR® |
| <p>01505: Construction & Demolition Waste Management Plan</p> | |

Recommendation

Reduce waste and save money by maintaining a reuse pile—also called a cut-pile—for wood, drywall, siding and other building materials.

Description

Up to 20% of construction materials are wasted due to inefficient practices. A significant amount of material can be saved by designing wood-framed buildings with advanced framing techniques, also know as Optimal Value Engineering or OVE. Another method is to design buildings on a modular floorplan so that dimensional products don't need to be cut and discarded (*Structure: Measure 05—Advanced Framing Design*).

During framing, plan to reuse wood studs, sheathing, joists and other materials by creating an organized cut-pile in a central location. Scrap ends and other small pieces that would otherwise be thrown away can be reused. This can save contractors material and money.

Follow the same practice for drywall, siding, piping, metal products, roofing, and even fiberglass insulation. Take care to properly cover and store reusable materials so that they are not damaged.

Benefits

Efficient material use reduces consumption of virgin resources and reduces the cost of construction material and waste disposal.

Application

Applicable to all new construction and major renovation projects.

A cut-pile requires an open, clean space to store materials. During the rainy season, a cover is necessary. When storing materials in a loose pile, be sure to consider safety.

Design Details

Reuse piles should be an integral part of the waste management plan (*Sitework: Measure 01—C&D Waste Management*).

Separating dimensional materials for reuse also makes it easier to donate unused materials once the project is finished, because materials are already sorted (*Finishes & Furnishings: Measure 08—Reclaimed Materials*).



Note: Cover and store all materials appropriately and keep them dry. Sheetrock, wood, sheathing and other porous materials can absorb moisture, which may lead to mold growth and indoor air quality problems (*Planning & Design: Measure 12—Moisture Shedding and Mold Avoidance*).

Provide large signs in bold colors to designate reuse piles and differentiate them from recycling and waste materials.

Code Considerations

Cut-piles must follow all OSHA and local jobsite safety regulations.

Considerations for Residents

None.

Cost and Cost Effectiveness

| | |
|----------------|--------|
| BENEFIT | ★★★ |
| COST | \$\$\$ |

Cut-piles require minimal labor. Subcontractor training and start-up take some effort, but the savings in material costs are more than worth it. Studies of single-family developments found that using cut-piles during the construction of an average California home saves \$800 in lumber costs.

Resources

- » **ACWMA's Builders' Guide to Reuse and Recycling** lists salvage and reuse organizations in Oakland and Berkeley: Tel. (510) 614-1699 www.multifamilygreen.org



Using a pile such as this one at the Habitat for Humanity Fruitvale development will greatly reduce waste during construction.

CONSTRUCTION IAQ MANAGEMENT

Reduce Indoor Air Contamination with an IAQ Management Plan

| WHO | KEY BENEFITS |
|--|--|
| <ul style="list-style-type: none"> ✓ Developer/PM Funder Policymaker ✓ Architect ✓ Builder Resident Building Manager | <ul style="list-style-type: none"> ✓ Health/IEQ ✓ Site/Community Energy Efficiency Water Efficiency Material Efficiency ✓ O&M ✓ Resident Satisfaction ENERGY STAR® |
| <p>01400: Quality Requirements</p> | |

Recommendation

Develop and execute an IAQ Management Plan for construction and preoccupancy phases.

Description

During construction, there are many opportunities to contaminate a building and adversely affect indoor air quality. Some of these contaminants are short lived; others may exist for the life of the building.

One way to minimize contamination is to develop and carry out a construction IAQ management plan. Such a plan spells out appropriate strategies for minimizing construction-related IAQ problems.

To further reduce the potential for IAQ problems, a preoccupancy plan should be carried out. Strategies include flushing out the spaces by circulating fresh air for a specified time to allow finish materials to offgas.

Benefits

Implementing an IAQ management plan during construction can reduce indoor air quality problems for workers in the short term and occupants in the long term.

A preoccupancy building flush-out may reduce problems associated with sick building syndrome, resulting in a healthier home.

Application

Applicable to all new construction and renovation projects.

Roles and Responsibilities

In contract documents, specifically state the role of each party in the construction IAQ management plan, from architect to subcontractor. In project meetings, include regular discussions of the IAQ plan and goals, and include all relevant parties, including subcontractors.

The builder and general contractor are typically responsible for implementing the plan during construction and before occupancy. Some developers will use an architect to help draft the plan; this can be an effective way to also discuss other green building goals on the project.

Architects should help identify materials that reduce IAQ problems, such as products with low levels of volatile organic compounds (VOCs). *(For information about selecting low-toxic materials, see the Finishes section of these Guidelines.)* The architect should list products that have potential for causing problems, and offer control measures for handling those materials *(Sitework: Measure 04—Hazardous Materials and Waste)*.

Design Details

DURING CONSTRUCTION

IAQ management practices during construction deal primarily with protecting the HVAC systems (assuming forced-air ventilation, heating or air conditioning systems are installed) and protecting building materials from moisture.

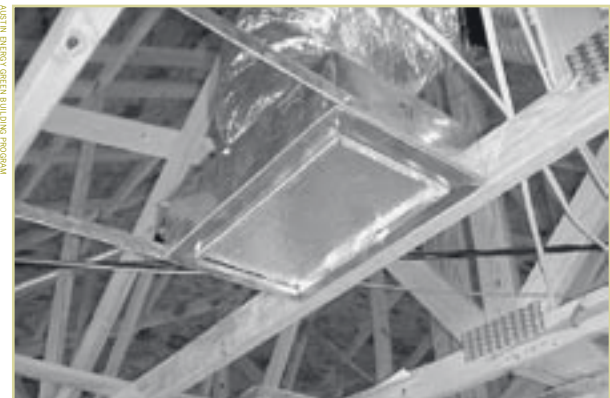

This supply vent register has been blocked to reduce contamination of the ductwork during construction.

HVAC systems can accumulate a lot of dust and contaminants during construction if they are not protected. Reducing their use (especially on the return side) during construction will help keep particulates, VOCs and other contaminants out of the system. Once inside, these contaminants are difficult to remove and may remain for years.

Another ventilation control strategy is to filter and/or seal the HVAC system during certain construction times. Painting, sanding and other practices can emit particles that become trapped in the HVAC system. Provide temporary filters on the return ducts and seal all registers and penetrations as needed to reduce contamination. Change the filters regularly prior to completion, and again before occupancy. For systems that provide fresh air, ventilate using 100% outside air throughout construction.

Here are more housekeeping ideas to protect IAQ during construction:

- » Collect and review Material Safety Data Sheets (MSDS) for all proposed materials to identify hazards and obtain guidance on safe use
- » Cover and protect HVAC equipment until installed
- » Keep materials like wood, drywall and insulation away from moisture sources to avoid mold growth
- » If using damp-spray cellulose insulation, allow it to dry thoroughly before closing it in (*Structure: Measure 09—Insulation*).
- » Clean up spills immediately
- » Clean work areas regularly to avoid contaminant buildup and improve safety

PREOCCUPANCY

After construction is finished, proper cleaning of the jobsite is necessary. Clean all surfaces thoroughly. Brush, vacuum and clean fans and ducts, and change filters on the HVAC system before testing and balancing is performed.

Install porous materials, like carpeting and furniture, only after finish materials have cured. To reduce offgassing of VOCs into the building, air out carpeting and furniture for a period (up to two weeks) before installing.

Once the site is clean, conduct a two-week building flush-out. This allows for proper curing of paints and finishes, offgassing of materials, and filtration of the ventilation system.

If scheduling constraints don't allow time for airing out materials or flushing out the building prior to occupancy, the design team should place even greater emphasis on specifying low-VOC products, materials and furnishings.

Code Considerations

Construction workers must wear appropriate devices to protect against dust and VOCs. Adequate ventilation during construction must be provided. OSHA and other regulations guide these practices.

Considerations for Residents

Protects occupant health and may increase satisfaction.

Cost and Cost Effectiveness

| | | |
|---------|--------|--|
| BENEFIT | ★★★ | Implementing an IAQ management plan during construction will probably result in additional labor and time. Contractor scheduling and training sessions will also likely increase labor time. A two-week flush-out may be difficult to cost-justify, but if planned properly, some work can be done at this stage, such as painting with zero-VOC products or installing floating floors without adhesives. |
| COST | \$\$\$ | |

A properly executed IAQ management plan may save money by helping to protect worker health and improve productivity, reduce client and occupant call-backs, and extend the life of ventilation systems.

Resources

- » Most of the material for this measure was derived from the **LEED New Construction Reference Guide:** www.usgbc.org.
- » **Sheet Metal and Air Conditioning National Contractors Association (SMACNA)** publishes useful IAQ management guidelines, including *IAQ Guidelines for Occupied Buildings Under Construction and Indoor Air Quality: A Systems Approach*. Tel. (703) 803-2980 www.smacna.org
- » **Building Green**, publisher of *Environmental Building News*, has an article on construction IAQ management practices (Vol. 11, No. 5), and a paper on Top 10 IAQ strategies: www.buildinggreen.com www.buildinggreen.com/elists/halpaper.com

HAZARDOUS MATERIALS AND WASTE

Reduce Potential Pollution and Health Risks

| WHO | KEY BENEFITS |
|---|---|
| <ul style="list-style-type: none"> ✓ Developer/PM Funder Policymaker ✓ Architect ✓ Builder Resident ✓ Building Manager | <ul style="list-style-type: none"> ✓ Health/IEQ ✓ Site/Community Energy Efficiency Water Efficiency ✓ Material Efficiency ✓ O&M ✓ Resident Satisfaction ENERGY STAR® |

01500: Hazardous Waste Management Plan,
16501: Electrical Component Recycling

Recommendation

Minimize the amount of hazardous materials used and hazardous waste created in the construction and maintenance process by following the three R's: reduce, reuse and recycle.

Description

Hazardous wastes typically generated on a jobsite include paint, solvent, adhesive, caulk, pesticide, wood preservative, asphalt, tar, oil (from trucks), kerosene (from portable heaters), and more.

Managing hazardous waste consists of the three R's: reduce, reuse and recycle. After exhausting those options, proper disposal is essential.

Reduce. First, purchase materials that are less toxic. Second, maintain good waste management practices to avoid spills, emissions and other wasteful mistakes.

Reuse. Once a hazardous material is on site, consider ways to reuse it. Paint thinner, for example, can be reused several times. Materials exchange programs are also available.

Recycle. Some hazardous waste can be recycled. Appropriate storage, pick-up and delivery must be arranged, and must be performed according to applicable laws.

Benefits

Benefits include reduced pollution of land, air and water; lower risk of endangering health; reduced risk of costly clean-up; potential for fewer occupant complaints; and setting a positive example in the community

Application

All new construction and major renovations. Also applicable to ongoing maintenance practices.

Design Details

HAZARDOUS WASTE MANAGEMENT PLAN

Develop a hazardous waste management plan that includes waste reduction, reuse and recycling. In the construction documents, specify handling and disposal of hazardous materials. The first steps are to list types and quantities of hazardous waste that might be generated and to target areas for substitutions and reduction.

PURCHASING STRATEGIES

Whenever possible, select materials that are low in toxicity and don't contribute to hazardous waste:

- » Manage ordering of hazardous materials to prevent overstocking and waste.
- » Let suppliers know you want the least toxic product for the application.
- » Obtain Material Safety Data Sheets (MSDS) for each product. Review for potentially hazardous compounds. Common hazardous attributes are high ignitability, corrosiveness, reactivity and toxicity.

Safer alternatives exist for most common products:

Adhesives. Solvent-free adhesives and sealants work well for general and specific construction purposes (*Finishes & Furnishings: Measure 03—Adhesives and Sealants*).

Paints and wood preservatives. Water-based paints, wood stains and preservatives do not require toxic solvents such as paint thinner for clean up (*Finishes & Furnishings: Measure 02—Interior Paint*).

Metal primers. Use low-VOC metal primer where possible. If necessary, spot-prime with a rust-inhibiting oil-based product.

Pesticides. Reduce or eliminate pesticides in landscaping and construction (*Planning & Design: Measure 08—Landscaping*).

Lamps. Specify low-mercury fluorescent lamps (*Systems: Measure 13—High-Efficiency Lighting*).

Solvents. Consider citrus-based solvents instead of chlorine-based solvents.

Form releasers. Purchase materials with the lowest toxicity.

Cleaners. Select nontoxic cleaners.

USING AND STORING TOXIC MATERIALS

When toxic materials must be used, these strategies can help extend their life:

- » Use solvents such as paint thinner more than once. Strain and reuse for cleaning equipment or other uses before discarding.
- » Provide adequate secured space for the storage of hazardous materials.
- » Keep all containers sealed to reduce evaporation and VOC emissions.

Train construction staff on proper hazardous waste management, including spill and clean-up procedures for each product (*see the MSDS*).

Teach tenants about safer cleaning and maintenance practices and products (*Operations & Maintenance: Measure 01—Trainings and Manuals*).

RECYCLING AND DISPOSAL

Finally, after reducing and reusing, attempt to recycle any remaining products. For-profit entities can often donate leftover products to nonprofits for a tax credit. Another option is to take hazardous wastes to appropriate recycling facilities (*Sitework: Measure 01—C&D Waste Management*).

After exhausting all other options, ensure proper disposal of hazardous materials. Take toxics to legitimate treatment, storage and disposal (TSD) facilities, or solid waste management facilities.



Ensure that all containers are clearly labeled, and routinely check bins of discarded materials for potential pollution sources. Disposing of hazardous waste with nonhazardous waste causes contamination problems at landfills, poses health and groundwater problems, and is illegal.

Code Considerations

Businesses are liable for hazardous waste disposal, spills and other contamination issues under federal and state law. Controlled materials are listed in California Code of Regulations (CCR) Title 22, Division 4.5, or Code of Federal Regulations (CFR) 40, Parts 110, 117, 261 or 302.

Considerations for Residents

Safer and cleaner environment and home.

Cost and Cost Effectiveness

| | | |
|----------------|--------|--|
| BENEFIT | ★★★ | Implementing a hazardous waste management plan is an important part of responsible construction practices. Training staff on proper procedures can add time, but will reduce liability. Some low-toxic materials cost more than standard products, but result in lower disposal costs. |
| COST | \$\$\$ | |

Resources

- » **ACWMA's Alameda County Recycling Guide** is a comprehensive guide to recycling and reuse: www.multifamilygreen.org
Tel. (510) 614-1699
- » **U.S. Environmental Protection Agency** Regulations on hazardous waste: www.epa.gov/epaoswer/osw/hazwaste.htm
Peaks to Prairies. *Residential Construction Contractor's Guide*, Section 8, Hazardous Materials: <http://peakstoprairies.org/p2bande/Construction/ContrGuide>
- » **EcoBuilding Times** article: www.ecobuilding.org/lib/ebt/2000/obrien.htm

This section addresses the building's structure and envelope, including concrete, framing, roofing and siding materials, insulation and windows. Following the recommendations in these Guidelines will result in more durable buildings that use energy and other resources more efficiently.

Most of these recommended measures represent improvements to, not drastic departures from, standard construction practices. For example, fiberglass batt insulation with no added formaldehyde (*Structure: Measure 09*) is installed, performs and costs the same as standard fiberglass batts, plus it helps protect health by reducing exposure to a hazardous air pollutant. Engineered lumber (*Structure: Measure 04*) can replace many types of solid-sawn lumber; it is sometimes slightly more expensive, but is typically more dimensionally stable, straighter, lighter and stronger.

It's important that each of these measures be considered within an integrated design process (*see the Guidelines' introduction for more about integrated design*). This will help maximize the building's energy efficiency while reducing costs for individual measures.



STRUCTURE

BENEFITS

This table lists the Guidelines' Structure measures, and shows the primary benefits of each (see the individual measures for details).

| MEASURE | BENEFITS | | | | | | | |
|-----------------------------------|------------|----------------|-------------------|------------------|---------------------|-----|-----------------------|--------------|
| | Health/IEQ | Site/Community | Energy Efficiency | Water Efficiency | Material Efficiency | O&M | Resident Satisfaction | ENERGY STAR® |
| 01 Recycled aggregate | | | | | ✓ | | | |
| 02 High-volume flyash in concrete | | | ✓ | | ✓ | ✓ | | |
| 03 FSC-certified wood | | | | | ✓ | | | |
| 04 Engineered lumber | | | | | ✓ | | | |
| 05 Advanced framing design | ✓ | | ✓ | | ✓ | | ✓ | ✓ |
| 06 Steel framing | ✓ | | | | ✓ | | | |
| 07 Structural insulated panels | | | ✓ | | ✓ | | ✓ | ✓ |
| 08 Raised heel trusses | | | ✓ | | ✓ | | ✓ | ✓ |
| 09 Insulation | ✓ | | ✓ | | ✓ | | ✓ | ✓ |
| 10 Durable siding | ✓ | | ✓ | | ✓ | ✓ | ✓ | |
| 11 Durable roofing | ✓ | | ✓ | | ✓ | ✓ | ✓ | |
| 12 Cool roof | ✓ | ✓ | ✓ | | | ✓ | ✓ | ✓ |
| 13 High-performance windows | ✓ | | ✓ | | | ✓ | ✓ | ✓ |

| EXPLANATION OF BENEFITS |
|---|
| <p>Health/IEQ: Reduces indoor pollutants, promotes better indoor environmental quality, and/or provides opportunities for improved public health.</p> <p>Site/Community: Protects land, water and air on and near site from pollution or other environmental damage, uses municipal infrastructure more efficiently by redeveloping building or site, and/or provides important and needed amenities for the surrounding community.</p> <p>Energy Efficiency: Reduces building energy consumption.</p> <p>Water Efficiency: Reduces water use in building and/or on site.</p> <p>Material Efficiency: Reduces, reuses and/or recycles materials that might have otherwise ended up in landfills, reduces materials needed to construct or operate the building, and/or uses materials produced in a way that minimizes environmental damage.</p> <p>O&M: Increases building's durability, and/or reduces operating and maintenance expenses.</p> <p>Resident Satisfaction: Saves residents money and/or improves residents' quality of life.</p> <p>ENERGY STAR®: Helps achieve ENERGY STAR® for Homes certification.</p> |

KEY CONSIDERATIONS

CONTRACTOR EXPERIENCE

Some of the products and techniques described in this section require experience or specialized skills that aren't found on every construction crew. For example, the techniques for designing and working with high-volume flyash concrete (*Structure: Measure 02*) are still new to many engineers and contractors. Similarly, if installing damp-spray cellulose insulation (*Structure: Measure 09*), you need an experienced subcontractor who knows how to avoid moisture-related problems. With steel framing (*Structure: Measure 06*), a more skilled labor force is usually needed. As early as possible in the design phase, the project team should identify any measures that might diverge from standard practice.

PRODUCT AVAILABILITY

Many of the materials recommended here are readily available. For example, many cities in Alameda County have ordinances requiring construction site waste recycling, so there is plenty of recycled aggregate available (*Structure: Measure 01*). High-volume flyash mixes (*Structure: Measure 02*) are also widely available in the Bay Area, as are recycled-content insulation with no added formaldehyde (*Structure: Measure 09*), engineered lumber (*Structure: Measure 04*), and high-performance windows (*Structure: Measure 13*). Other products may require more effort to obtain. While FSC-certified hardwoods (*Structure: Measure 03*), for instance, are generally more readily available than FSC softwoods, supply fluctuates, which affects both availability and price. Early in the design phase, the project team should flag any products or materials that might have longer lead times or require extra effort to source so that the contractors can work to ensure that they will be on hand when needed.

COST

An integrated design approach will help reduce construction costs as well as operating costs. For example, it may be possible to downsize or eliminate the air-conditioning system if the design includes a cool roof (*Structure: Measure 12*) combined with other energy-saving features, such as overhangs, increased insulation, high-performance windows and proper building orientation.

Other measures may cost more than conventional construction if the product itself is more expensive, the technique is more labor intensive, or the contractors have limited experience with the technique and therefore submit higher bids. For example, studies have estimated that, overall, installed steel framing (*Structure: Measure 06*) costs anywhere from 0% to 7% more than wood framing, mostly because of increased labor costs. However, steel prices are more constant than wood prices, resulting in longer price guarantees from manufacturers, which helps with project budgeting.

Compared to conventional wood framing, advanced wood framing design (*Structure: Measure 05*) does require some additional effort during design and careful oversight of the framing contractor in the field. But it can reduce lumber use by as much as 20% to 30%, while also providing more room for insulation and increasing the building envelope's energy efficiency. Refer to the individual measures for more information about the savings and costs associated with the structural components of green multifamily housing.



Advanced framing design elements, such as 24-inch stud spacing and headers made from engineered lumber, save resources while improving building performance. This photo was taken during construction at the Fruitvale Habitat for Humanity project in Oakland.

ROLES AND RESPONSIBILITIES

- » **Policymaker and code official.** To help pave the way for more sustainable building practices in your community, stay current on new construction techniques, such as high-volume flyash concrete (*Structure: Measure 02*), structural insulated panels, or SIPs (*Structure: Measure 07*), and advanced framing design (*Structure: Measure 05*).
- » **Developer and project manager.** Support an integrated design approach that evaluates costs and benefits within the context of whole-building design and construction. Be alert to products and techniques that builders may be unfamiliar with or that may take more effort to source; discuss these issues regularly in project meetings. Recognize that increased design fees related to integrated design are often recouped during construction.
- » **Funder.** Some of the recommended measures cost more but will result in buildings that are more durable and cost less to operate. Seek financing solutions that promote quality construction and long-term savings.
- » **Architect.** Stay informed about high-performance products and techniques. Promote an integrated design process and be able to articulate to the project team how the individual features of a design add up to more than the sum of their parts. Involve building officials in the project early. If the design calls for construction methods or products that aren't standard practice, work with the developer to help ensure that qualified contractors are hired, and provide those contractors with the information and resources that will help them successfully build your design. When necessary, seek design assistance from consultants with specific expertise.
- » **Builder.** Keep current on the latest high-performance products and construction methods. Develop a network of subcontractors who are committed to practicing high-quality green construction. If the design calls for products or techniques you or your subs are unfamiliar with, discuss these issues early and openly during project meetings so that the team can work together to ensure success.

FOCUS ON STRUCTURE: Carmen Avenue

This 30-unit community, to be built in Livermore by Allied Housing, is designed to be comfortable and energy efficient even when summer temperatures exceed 100°F. The goal is to reduce the need for air conditioning to the point where it is rarely required. Almost all glazing is on the south and north sides, with overhangs on the south facades for shading. Passive solar heating/cooling has been incorporated into the design, including 5/8-inch gypboard on walls and ceilings to provide a small amount of thermal mass. Formaldehyde-free fiberglass batt insulation in the walls (R-19) and loose-fill cellulose in the roof cavity (R-38), plus low-e insulated glazing with vinyl windows, will help keep the units comfortable while reducing utility bills. Natural ventilation from consistent afternoon breezes and cool night air contribute to the comfortable, energy-efficient design.

To learn more about this project, see to the Carmen Avenue case study.

RECYCLED AGGREGATE

Specify Recycled Aggregate for Fill, Backfill and Other Uses

| WHO | KEY BENEFITS |
|--|--|
| <ul style="list-style-type: none"> ✓ Developer/PM Funder Policymaker ✓ Architect ✓ Builder Resident Building Manager | <ul style="list-style-type: none"> Health/IEQ Site/Community Energy Efficiency Water Efficiency ✓ Material Efficiency O&M Resident Satisfaction ENERGY STAR® |
| <p>03052: Concrete Aggregates</p> | |

Recommendation

Specify recycled aggregate whenever CalTrans Class II materials are specified.

Description

CalTrans Class II aggregate is used as fill under slabs, for backfill and for other uses. Virgin aggregate comes from sources such as riverbeds and quarries, which disturbs the environment.

Recycled aggregate—typically clean, crushed concrete—is generally available in Alameda County as an alternative to virgin materials. This concrete is removed from demolished buildings and sitework, and is processed and cleaned for reuse.



Concrete being sorted for reuse as aggregate.

Benefits

Construction and demolition (C&D) debris constitutes approximately 21% of the materials landfilled in Alameda County. Keeping concrete out of landfills benefits the county and makes good use of the material.

Because concrete is expensive to landfill, and because many cities in Alameda County have ordinances requiring construction site waste recycling, there is plenty of recycled aggregate available.

Application

Applicable wherever Class II aggregate is specified, for example as backfill drainage, and under parking, sidewalks and building slabs.

Design Details

If a project is built on a formerly developed site, consider crushing concrete on site to supply aggregate for the new development.

Code Considerations

| | | |
|----------------|--------|---|
| BENEFIT | ★★★ | Check with the local building department to ensure that recycled aggregate can be used without complications from the city. If you need assistance or information, contact the Alameda County Waste Management Authority. |
| COST | \$\$\$ | |

Considerations for Residents

None.

Cost and Cost Effectiveness

Recycled aggregate costs the same as standard aggregate: between \$1 and \$18 a ton, depending on availability.

Resources

- » **ACWMA's Builders Guide to Reuse and Recycling** lists suppliers of recycled products, including crushed concrete:
Tel. (510) 614-1699
www.multifamilygreen.org

HIGH-VOLUME FLYASH IN CONCRETE

Use Concrete Mixes with a High Volume of Flyash

| WHO | KEY BENEFITS |
|--|--|
| <ul style="list-style-type: none"> ✓ Developer/PM Funder Policymaker ✓ Architect ✓ Builder Resident Building Manager | <ul style="list-style-type: none"> Health/IEQ Site/Community ✓ Energy Efficiency Water Efficiency ✓ Material Efficiency ✓ O&M Resident Satisfaction ENERGY STAR® |
| 03300: Cast-In-Place Concrete | |

Recommendation

Use high-volume flyash concrete.

Description

Flyash is a waste product of coal-fired electrical power plants. In the United States, about 60 million tons of powdered flyash is removed from the exhaust of these power plants every year to reduce air pollution. Less than 30% of that flyash is recycled. The rest is landfilled.

One common method of recycling flyash is to use it to replace a portion of the portland cement in concrete. Concrete consists of sand, aggregate, cement and other admixtures. Most existing recommended practices limit flyash usage to 15% or 20% of the cement portion of concrete. This increases the strength and improves the durability of concrete. But using a higher volume of flyash yields greater strength benefits and diverts a larger amount of this waste from landfills.

High-volume flyash is typically defined as concrete that contains more than 30% flyash in the cement portion of a concrete mix.

Benefits

Flyash improves the performance of concrete by increasing strength, reducing permeability and reducing corrosion of reinforcing steel.

The environmental benefits are reduced waste in landfills, lower energy use (manufacturing portland cement is very energy intensive), and fewer greenhouse gas emissions.

Cement is made by heating limestone and other minerals to 2700°F in large kilns. For every ton of cement produced, about 1400 pounds of carbon dioxide (CO₂) are released into the atmosphere; in fact, the cement industry contributes about 8% of all the manmade CO₂

in our atmosphere. CO₂ is one of the primary greenhouse gases that contributes to global warming. Reducing the use of cement in concrete is one way to help reduce global warming.

Application

High-volume flyash is appropriate for use in footings, mat foundations, slabs on grade, slabs on metal decks, cast-in-place and tilt-up walls, drives, sidewalks and equipment pads. Consult with an expert before using high-volume mixes in columns and with post-tension systems.



Design Details

Although flyash has been used in concrete for decades, the techniques for designing and working with high-volume flyash concrete are still new to many engineers and contractors, so it is important to discuss flyash early in the design phase.

Flyash reaches its maximum strength more slowly than typical mixes, although this can be partially addressed by the use of low-water mixes. In some cases, this added time can affect construction scheduling, so be sure to get this information early from the engineer.



High-volume Ready Mix with 50% flyash should be mixed with 20% to 25% less water than a product with no flyash. The water quantity is the key to keeping cure time reasonable because accelerant admixtures are expensive and not always effective. The downside is that workability—including surface finishing—can be somewhat more difficult. It is therefore important to use concrete finishers who are experienced in working with high-volume flyash concrete.

Code Considerations

ASTM sets standards for the chemical composition of flyash, but does not specifically limit the amount in concrete. In standard construction, the amount of flyash specified in concrete has been limited to 15% or 20%. This resistance to changing standard practice may be a larger barrier than any locally applicable codes.

Considerations for Residents

None.

Cost and Cost Effectiveness

| | | |
|----------------|---------|---|
| BENEFIT | ★★★ | High-volume flyash concrete mixes are widely available in the San Francisco Bay Area and cost the same as low-volume mixes. However, contractor bids for using high-volume flyash can be high if the contractor is unfamiliar with working with it. To avoid surprises, have the structural engineer discuss concrete with the contractor early on. |
| COST | \$ \$\$ | |

Resources

- » **Portland Cement Association** provides resources for the specification, application and use of all types of cement, concrete construction, and concrete products including flyash:
www.cement.org
- » **Building Green** has resources on high-volume flyash concrete: www.buildinggreen.com
- » **Environmental Design and Construction** magazine has articles on high-volume flyash concrete:
www.edcmag.com
- » **ACWMA's** Materials Database lists products that correspond with this measure:
www.multifamilygreen.org

FSC—CERTIFIED WOOD

Use Wood Products Certified by the Forest Stewardship Council (FSC)

| WHO | KEY BENEFITS |
|------------------|-----------------------|
| Developer/PM | Health/IEQ |
| ✓ Funder | Site/Community |
| ✓ Policymaker | Energy Efficiency |
| ✓ Architect | Water Efficiency |
| ✓ Builder | ✓ Material Efficiency |
| Resident | O&M |
| Building Manager | Resident Satisfaction |
| | ENERGY STAR® |

06100: Rough Carpentry, **06400:** Architecture Casework/Woodwork, **09600:** Wood Flooring

Recommendation

Specify FSC-certified wood for wood applications, including framing, flooring, trim, cabinets, decking and fencing.

Description

The Forest Stewardship Council (FSC) is a nongovernmental organization that promotes standards for sustainable forestry certification worldwide and accredits forestry certifiers. FSC principles include management for biological diversity, long-term forest health and long-term economic well-being of local communities.

FSC tracks and monitors wood throughout the chain-of-custody—as it moves from harvesting to manufacturing and distribution and finally to the point of sale—to ensure that the customer is actually getting a certified sustainably harvested product.

FSC® CERTIFIED WOOD PRODUCT



The Forest Stewardship Council logo. Look for this label to ensure that wood products come from well managed forests.

FSC authorizes third-party certifying organizations to carry out certification. In the United States, these organizations are SmartWood and Scientific Certification Systems (SCS). These groups certify forest lands and chain-of-custody forest products based on FSC standards.

Benefits

FSC certification guarantees that forests are managed in a way that will assure the long-term availability of wood while protecting the health of forests and the natural resources they contain and support.

Application

FSC lumber is now available in framing dimensions (2x4 through 2x12), as plywood, and as other engineered wood products.

Design Details



It is important to coordinate with suppliers in advance to ensure availability and secure the best pricing. FSC-certified hardwood (for cabinet faces and floors, for example) is more readily available and cost effective than FSC-certified softwood (for more information about environmentally preferable wood products, see *Structure: Measure 04—Engineered Lumber / Structure: Measure 05—Advanced Framing Design / Structure: Measure 08—Raised Heel Trusses / Structure: Measure 10—Durable Siding / Finishes & Furnishings: Measure 07—Wood Flooring Alternatives*).

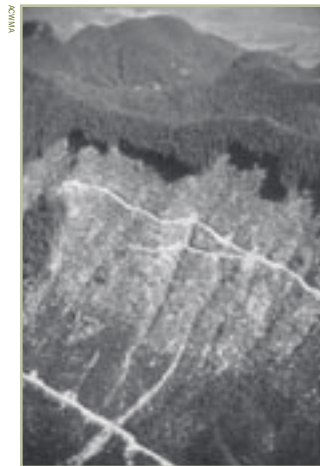

Poorly managed timber harvesting practices can damage ecosystems and harm the long-term economic well-being of local communities.

Code Considerations

There are no code issues with certified wood.

Considerations for Residents

FSC-certified wood has no direct effect on occupants.

Cost and Cost Effectiveness

| | | |
|----------------|--------|---|
| BENEFIT | ★★★ | FSC-certified hardwoods are easier to find and more affordable than FSC-certified softwoods. FSC softwood prices are generally higher than noncertified lumber, while FSC hardwoods are generally about the same price. |
| COST | \$\$\$ | |

Resources

- » **Forest Stewardship Council (FSC)**
Maintains online lists of certified forests and chain-of-custody suppliers:
Tel. (202) 342-0413
www.fscus.org
- » **Metafore** (formerly part of the Certified Forest Products Council).
Provides information about certification programs, and lists of certified forests and forest products:
Tel. (503) 224-2205
www.certifiedwood.org
- » **Certified Wood and Paper Associates**
The CWPA works with architects, builders, specifiers, and others to help write correct specifications and find available FSC products:
Tel. (503) 224-7696
www.cwpa.info
- » **ACWMA's** Materials Database lists products that correspond with this measure:
www.multifamilygreen.org

Third-Party Certifier of Wood Products

These independent certification organizations maintain online lists of certified forests and chain-of-custody suppliers.

- » **Scientific Certification Systems**
Tel. (510) 452-8000
www.scscertified.com
- » **Smartwood**
Tel. (802) 434-5491
www.smartwood.org

ENGINEERED LUMBER

Use Resource-Efficient Engineered Lumber Instead of Solid-Sawn Lumber

| WHO | KEY BENEFITS |
|--|--|
| <ul style="list-style-type: none"> ✓ Developer/PM Funder Policymaker ✓ Architect ✓ Builder Resident Building Manager | <ul style="list-style-type: none"> Health/IEQ Site/Community Energy Efficiency Water Efficiency ✓ Material Efficiency O&M Resident Satisfaction ENERGY STAR® |

DIVISION 6: Wood and Plastics

Recommendation

Substitute solid-sawn lumber with engineered lumber.

Description

Solid-sawn lumber in sizes 2x10 and greater typically comes from old-growth forests. Engineered lumber products, on the other hand, come from small-diameter, fast-growing plantation trees. These products include glued laminated timber (glulam), laminated veneer lumber (LVL), laminated strand lumber (LSL), parallel strand lumber, wood I-joists (TJI), wood floor trusses, oriented strand board (OSB) and other manufactured wood structural materials. These are described in more detail below:

- » **Glulams:** Layers of dimensional lumber bound together. Can span great distances.
- » **LVL:** The outer veneer/layer of timber that is bound together. Useful for long spans and as headers.
- » **LSL:** Structural grade product made from fast-growing trees. Made up of long strands of wood fiber. Used where straightness is desired, such as for studs and rim joists.
- » **Parallel Strand Lumber:** Very strong engineered product made of long strands of lumber pressed together. Used for high density applications, such as headers and beams.

- » **TJIs:** OSB core “web” material sandwiched by either a parallel strand lumber product or solid core lumber. Used for floors and roof joists.
- » **OSB:** Cross oriented wood from fast-growing species are bound together. Used for sheathing and many other applications.

The wood fiber in engineered lumber products is bound together using various glues. One common binder is urea formaldehyde, which presents some concerns for indoor air quality, and can often be avoided (*for an in-depth discussion, see Finishes & Furnishings: Measure 09—Cabinets, Counters and Trim*).

Benefits

Engineered lumber can help improve energy efficiency by complementing OVE framing techniques that increase insulation levels (*Structure: Measure 05—Advanced Framing Design / Structure: Measure 09—Insulation*).

Engineered lumber manufacturing uses trees efficiently by making large-dimension materials out of wood chips and young trees. Engineered lumber is more dimensionally stable and straighter than conventional lumber because it does not have a grain and therefore does not expand and contract as much as solid wood.

Wood I-joists use up to 50% less wood fiber to perform the same structural function as similarly sized solid-sawn lumber, and they will not twist, warp or split. They are stronger, lighter and can span greater distances than 2x10s or 2x12s.

OSB is as strong as traditional plywood and is less expensive. Some OSB has a lower formaldehyde content than plywood, contributing to healthier indoor air quality.

Engineered beams such as glulams, parallel strand lumber, laminated strand lumber and laminated veneer lumber replace the need to use old-growth timber, while providing superior structural characteristics.

Fingerjointed studs are straighter and stronger than solid-sawn studs, helping eliminate crooked walls and reducing material waste.

Application

Applicable to all buildings where solid-sawn lumber is used.

Design Details

Plan for the use of engineered lumber from the beginning of the design phase. Take advantages of design synergies that can result in energy savings and materials reduction, such as with advanced framing.

Here are some strategies for designing with engineered lumber:

- » Joists: Replace with wood I-beams or engineered trusses
- » Non-load-bearing header: Replace with small members (double 2x6s)
- » Structural headers and beams: Use engineered headers and beams
- » Floor joists: Design on 19.2-inch centers to improve cost efficiency

Code Considerations

Most engineered lumber products have been code approved for 30 years or more.

Fingerjointed studs should only be used in vertical applications and must be integrated into the seismic engineering design.



I-beam floor joists use up to 50% less wood fiber to perform the same structural function as similarly sized solid-sawn lumber.

Considerations for Residents

Try to purchase engineered lumber that is not made with formaldehyde binders. Phenol formaldehyde binders, while not emitting as much formaldehyde as urea formaldehyde binders, may still pose an indoor air quality concern. The best binder option is a formaldehyde-free MDI (methyl diisocyanate) binder.

Cost and Cost Effectiveness

| | | |
|---------|--------|--|
| BENEFIT | ★★★ | Engineered lumber is cost competitive or slightly more expensive than conventional lumber. |
| COST | \$\$\$ | |

Some products, like I-beams, will actually require less labor to install, but may require that the laborers be more skilled. Engineered studs can save time because of straighter walls, resulting in less shimming needed to true walls.

Resources

- » **Building Green**, publisher of *Environmental Building News*, has product information and reviews: www.buildinggreen.com
- » **ACWMA's** Materials Database lists products that correspond with this measure: www.multifamilygreen.org

ADVANCED FRAMING DESIGN

Use Less Wood & Improve Energy Efficiency with OVE Framing

| WHO | KEY BENEFITS |
|--|--|
| <ul style="list-style-type: none"> ✓ Developer/PM Funder Policy maker ✓ Architect ✓ Builder Resident Building Manager | <ul style="list-style-type: none"> ✓ Health/IEQ Site/Community ✓ Energy Efficiency Water Efficiency ✓ Material Efficiency O&M ✓ Resident Satisfaction ✓ ENERGY STAR® |
| 06460: Wood Framing | |

Recommendation

Design framing with Optimum Value Engineering (OVE) techniques.

Description

OVE or advanced framing is the practice of using less wood to achieve the same structural integrity and increased energy efficiency. The National Association of Home Builders Research Center developed OVE framing in the early 1980s.

Benefits

OVE framing can reduce lumber requirements by 20% while increasing the envelope's energy efficiency. The larger the space between studs, the more room for higher-value insulation materials throughout the entire wall assembly.

OVE framing also reduces typical cold spots such as corners and intersections of the interior and exterior walls.

Application

Applicable to all new construction projects, although the techniques and recommendations are different for low-rise and mid-rise buildings.

Advanced wall framing should not be used for party walls.

Steel-framed buildings can also benefit from advanced framing by increasing insulation levels and reducing materials (*Structure: Measure 06—Steel Framing*).

This measure does not apply to concrete wall construction.

Design Details

OVE framing requires some additional wall elevation drawings during design, and careful oversight of the framing contractor in the field.

OVE framing includes the following techniques:

- » Expand stud spacing from 16 in. to 24 in. (first in interior walls, then in exterior)
- » Eliminate window/door headers in nonbearing walls
- » Use insulated headers on exterior walls
- » Align roof framing/trusses with the wall and floor framing (stack vertically)
- » Use header hangers instead of jack studs
- » Use two-stud corners with drywall clips
- » Use ladder blocking for interior partition intersections with exterior walls
- » Do not use jack studs or cripples under window openings

Design with 2-ft or 4-ft modules. Ensure windows and doors fit between two studs (and are not odd sizes that require extra studs to make them fit the rough area). As a result, fewer finish materials, like drywall, will be wasted (*for more information about resource-efficient framing, see Sitework: Measure 02—Efficient Use of Construction Materials / Structure: Measure 03—FSC-Certified Wood / Structure: Measure 04—Engineered Lumber / Structure: Measure 08—Raised Heel Trusses*).

Code Considerations

Advanced framing techniques are code approved by BOCA (Building Officials and Code Administrator's National Building Code) and IECC (International Energy Conservation Code) for one-to-two story residential buildings.

Advanced framing may not be code approved for all levels on multistory buildings over two floors. Check with code officials to determine parameters for all stories.

Single top plates are sometimes included in advanced framing but are generally not recommended in California due to code restrictions.

Check with local code officials for seismic considerations.

Considerations for Residents

OVE framing can increase occupant comfort and reduce energy bills.

Cost and Cost Effectiveness

| | | |
|---------|--------|--|
| BENEFIT | ★★★ | According to National Resources Defense Council (NRDC) efficient wood use in low-rise residential buildings can result in an 11% to 19% reduction in wood use (see Resources). |
| COST | \$\$\$ | |

Resources

- » **Natural Resources Defense Council (NRDC)** publishes a booklet titled “Efficient Wood Use in Residential Construction” (1998):
Tel. (415) 777-0220
www.nrdc.org/cities/building/rwoodus.asp
- » **Emeryville Resourceful Building Project**
A case study publication about a resource-efficient affordable housing project designed by Siegel & Strain Architects in Emeryville, CA:
Tel. (510) 547-8092
www.siegelstrain.com

POINT LOADING TRUSSES

Point loading is preferable to standard loading. When truss loads are stacked directly over 24”oc framing, it reduces the framing materials required and increases the insulation capacity of walls.

STANDARD LOADING

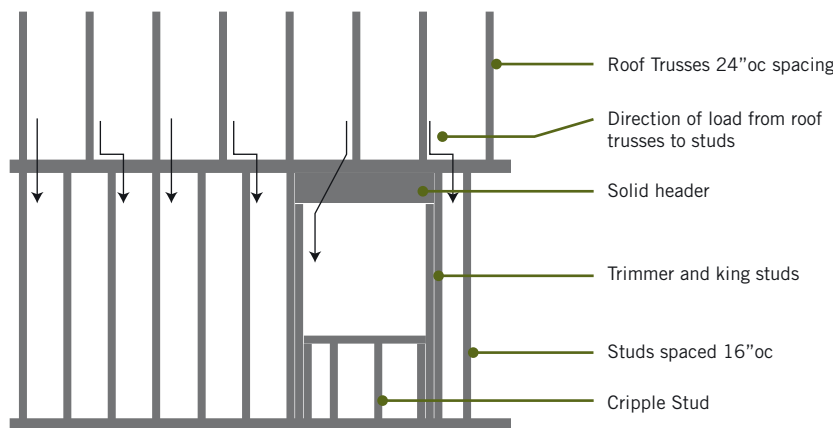

POINT LOADING

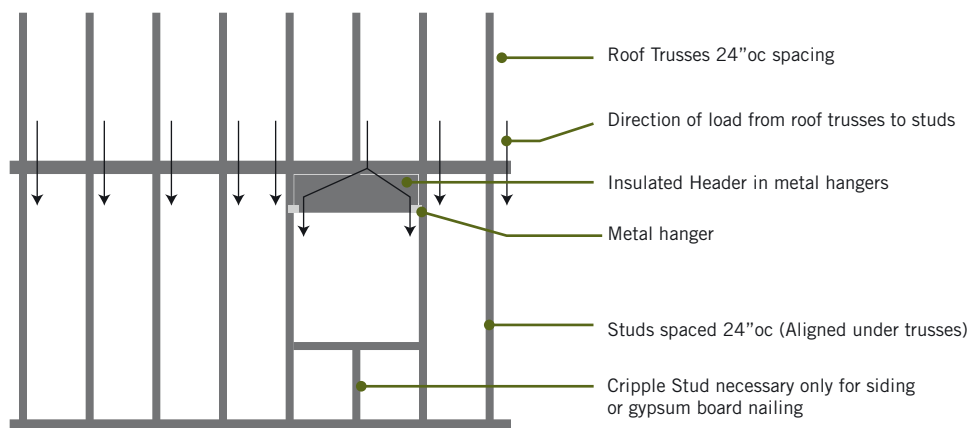

STEEL FRAMING

Steel: A Lightweight, Durable and Recycled Framing Material

| WHO | KEY BENEFITS |
|---|--|
| <ul style="list-style-type: none"> ✓ Developer/PM ✓ Funder Policymaker ✓ Architect ✓ Builder Resident Building Manager | <ul style="list-style-type: none"> ✓ Health/IEQ Site/Community Energy Efficiency Water Efficiency ✓ Material Efficiency O&M Resident Satisfaction ENERGY STAR® |
| 05400: Cold-Formed Metal Framing | |

Recommendation

Use high recycled-content steel instead of wood for framing. Ensure there is appropriate insulation detailing to minimize thermal bridging.

Description

Wood framing has been the norm in residential building for years. However, the loss of mature forests has led to rising costs and lower quality lumber, making steel an economically viable alternative. Structural insulated panels, or SIPs, are also attracting interest because of their quick assembly times and low cost (*Structure: Measure 07*).

Steel-framed buildings have numerous advantages over traditional wood structures (*see Benefits, below*). The greatest benefits of steel in buildings, however, may be realized as new construction methods are developed. Steel can span greater distances than wood, for example, and can be framed at greater stud distances (*Structure: Measure 05—Advanced Framing Design*). Replacing standard stud and insulation framing with new designs (panelized or pre-engineered systems) may yield superior results.

One area where steel continues to be closely scrutinized is energy efficiency. Steel conducts heat more than 200 times better than wood. If the design doesn't include adequate thermal breaks, serious heat transfer can occur through a process called thermal bridging. Even with thermal breaks, most steel-framed structures are less energy efficient than similar wood-framed buildings.

Advances in the industry, including recycled-content steel (typically 10% to 15% postconsumer content, with some companies now offering steel with over 60% postconsumer content) and increased pollution controls, have reduced some of steel's negative environmental impacts. Steel is also fully recyclable—an important environmental benefit—and can be made back into high-value steel.



Steel-framed building detail.

Benefits

Steel has numerous benefits over wood framing:

- » Greater stability and higher strength-to-weight ratio than wood
- » Will not warp, shrink or rot, is termite resistant, fireproof, and potentially can last longer than wood with less maintenance
- » Greater design flexibility because of steel's strength (larger open spaces are possible)
- » Can be designed and pre-cut to exact dimensions, reducing jobsite waste
- » Foundations may be less prone to movement problems because less weight is exerted downward (some steel framing weighs one-third that of wood). This may make it possible to reduce bracing requirements.
- » Walls and corners are square, resulting in quicker finish installations, including drywall
- » Holes pre-punched in framing webs can easily accommodate wiring and plumbing without compromising structural integrity
- » Not necessary to use treated lumber, reducing toxic compounds
- » Interference with television and radio signals is a myth

Application

Steel framing can replace lumber for most applications.

Design Details

STEEL VS. WOOD FRAMING

In a one-for-one replacement of wood framing, a more skilled labor force is needed to frame with steel. Steel framing is typically installed by a commercial framing crew, not a residential crew, which can mean higher labor rates. This is primarily because steel walls are in-line framed. Floor studs and roof rafters align with the wall framing, and studs are fastened to a top and bottom track instead of top and bottom wood plates. Steel tracks are not capable of transferring vertical loads, so bracing is needed, requiring more skill than wood framing.

Additionally, steel frames are screwed together instead of nailed. Nail guns are very fast and easy to use, making steel framing more labor intensive. However, screwed steel members can be disassembled during remodeling. Cutting steel framing with chop saws and electric snips also requires more skill than lumber cutting. Automatic-feed screw guns with self-drilling screws, pneumatic sheathing pin nailers, and portable plasma torches are increasingly used to reduce labor time, and promise to make steel more competitive.

PANELIZED AND PRE-ENGINEERED SYSTEMS

One way to reduce labor is to purchase panelized or pre-engineered building systems. Panelized systems include prefabricated walls, floors and roof components. Exterior sheathing and finish can be applied prior to erection. Some manufacturers offer pre-engineered systems in which building components are made prior to installation. Pre-engineered systems usually require crew training from the supplier. Both of these options can increase material cost by 15% or more, but can reduce labor and installation time and cost. It is not uncommon for panelized walls to be erected in one-fourth the time of stick-built structures, which is a particular advantage during inclement weather.

THERMAL BRIDGING

The biggest downside of steel framing is increased heating and cooling losses through thermal bridging. Thermal bridging occurs when steel studs span from the exterior to the interior of the building envelope. Because of steel's high conductivity, energy (heat or cold) easily moves through the metal. This minimizes the usefulness of insulation between studs. Thermal bridging essentially gives heat a way to bypass insulation, as shown in this illustration:

WOOD FRAMED

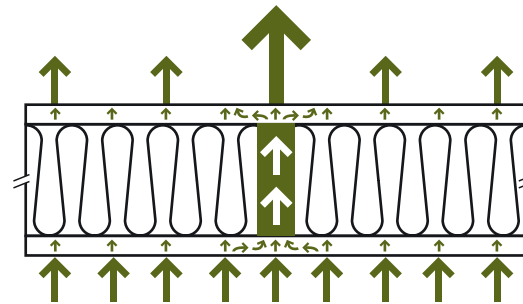

STEEL FRAMED

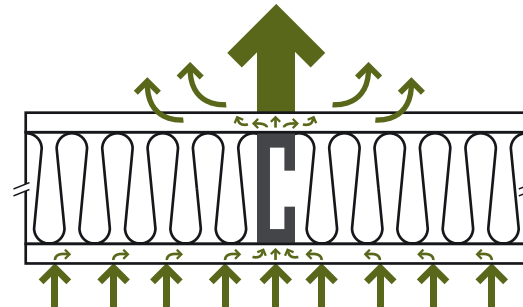

An insulated steel frame wall without thermal bridge-controlling measures will only perform 50% to 70% as well as a similarly built wood wall. Steel studs like the "C" channel shown here can effectively bypass much of the wall's insulation.

To lessen thermal bridging, use a thermal break to isolate the steel from any direct contact with the exterior or interior. On the inside, sheetrock is usually sufficient. On the exterior, a barrier with foam insulation is usually recommended.

Overall, strategies should reduce the transfer of heat where steel walls rest on concrete foundations, where roof truss members connect the attic to the interior, and where the bottom floor joists are located over unconditioned spaces. Other measures include:

- » Space studs at 24-inch centers and insulate between studs to increase overall R-value of walls
- » Use thinner (25-gauge) steel studs for nonbearing walls (thinner steel means less conductance)

Install a thermal break to the exterior, such as insulated sheathing. If the insulated sheathing is installed directly onto the studs with metal connectors, then thermal bridging through the metal connectors will occur. First install sheathing to the studs, then apply insulation to the sheathing.

Code Considerations

Request mill certificates from the roll-former and/or have steel members stamped with thicknesses and yield strengths to reduce confusion of builders during installation and code officials during inspections. If a panelized system is proposed, be certain local code officials have reviewed and approved the system.

Considerations for Residents

Steel does not offgas or need pest control. Steel-framed buildings without thermal barriers can have problems with fungal or mold growth because of condensation in the walls. Thermal breaks can significantly reduce this concern.

Occupants may have somewhat higher energy costs versus a wood building, even with thermal breaks.

Cost and Cost Effectiveness

| | | |
|----------------|--------|---|
| BENEFIT | ★★★ | Steel prices are more constant than wood prices, resulting in longer price guarantees from manufacturers. This helps with project budgeting, and, unlike lumber, reduces the stressful purchase and delivery timing game that contractors often face because of volatile lumber prices. |
| COST | \$\$\$ | |

Studies have estimated that, overall, installed steel framing costs anywhere from 0% to 7% more than wood framing, mostly because of increased labor costs. But this can vary significantly by assembly type: Steel floor assemblies cost less than engineered wood I-joint floors, while interior walls are consistent with wood costs. Adding appropriate thermal bridging control measures can make exterior walls more expensive than wood.

Resources

TRADE ORGANIZATIONS

- » **Steel Framing Alliance (SFA)** publishes guidelines for addressing thermal bridging:
www.steelframingalliance.com
- » **Steel Recycling Institute**
www.recycle-steel.org
- » **Northwest Wall and Ceiling Bureau**
www.nwcb.org/framing.php

ARTICLES

- » **Home Energy Magazine**
“Steel Framing, How Green?”
<http://hem.dis.anl.gov/eehem/01/010704.html>
“Steel Stud Walls: Breaking the Thermal Barrier”
<http://hem.dis.anl.gov/eehem/01/010715.html>
- » **PATH Technology Inventory**
www.toolbase.org (search for “Residential Steel Framing In-Depth Analysis”)
- » **Environmental Building News**, Vol. 3, No. 4 (1994), “Steel or Wood Framing: Which Way Should We Go?”
www.buildinggreen.com/features/svw/steel_vs_wood.cfm

STRUCTURAL INSULATED PANELS

Use Structural Insulated Panels (SIPs) for Walls, Roofs & Floors

| WHO | KEY BENEFITS |
|---|--|
| <ul style="list-style-type: none"> ✓ Developer/PM ✓ Funder Policymaker ✓ Architect ✓ Builder Resident Building Manager | <ul style="list-style-type: none"> Health/IEQ Site/Community ✓ Energy Efficiency Water Efficiency ✓ Material Efficiency O&M ✓ Resident Satisfaction ✓ ENERGY STAR® |
| 06123: Structured Insulated Panels | |

Recommendation

Use SIPs for structural exterior walls, roofs and floors in place of frame construction.

Description

SIPs consist of rigid expanded polystyrene foam (such as Styrofoam) sandwiched between two panels of oriented strand board (OSB). They come in nominal 4-in. to 12-in. thickness and have an insulation value of about R-4 per inch.



SIPs on a jobsite await installation.

Benefits

Compared to frame construction, SIPs are more energy efficient, offer enhanced structural performance, provide excellent soundproofing, and reduce air infiltration. They can be erected quickly, allowing for faster construction. They save wood by eliminating much of the lumber used in conventional framing.

Application

SIPs are applicable as solid, insulated exterior walls, roofs or floors where one would typically use wood frame construction. They are best used in residential and light commercial buildings.

Design Details

SIPs are fairly interchangeable with a frame construction design if the decision to use them is made early in the design process. However, SIPs are relatively new in the construction industry, and builders may need to be educated on how to build with them. Here are some design details to consider:

- » SIP construction results in very airtight buildings. Always provide mechanical ventilation to compensate (*Systems: Measure 10—Advanced Ventilation Practices*).
- » To keep costs down, use a 2x2-ft grid to lay out the major exterior walls, doors and windows.
- » Specify SIPs that come with special foam-sealing channels, or another comparable system, for sealing between panels during erection. This reduces moisture damage to the building exterior (*Planning & Design: Measure 12—Moisture Shedding and Mold Avoidance*). To further seal panels, tape interior panel joints with quality construction tape.
- » Where termites are a problem, use panels with foam and OSB that are treated to repel insects.
- » Predetermine plumbing and electrical runs so the manufacturer can form chases inside the foam for wire or pipes.
- » During construction, store panels under cover, out of the sun, and off the ground.
- » Install a 15-minute fire barrier (minimum of ½-in. drywall) between the SIP and living space.
- » Make sure specifications are exact to avoid waste; SIPs are not recyclable.
- » Use panel scraps for constructing headers, filler sections above windows, and other uses (*Sitework: Measure 02—Efficient Use of Construction Materials*).

Code Considerations

SIPs have been used in the United States for the past 30 years and have received code approval from the national code-making organizations. Some local code officials may have less experience with them and may request documentation from the panel manufacturer.

Considerations for Residents

The most notable benefits for occupants are reduced sound transmission, reduced energy bills and improved comfort.

To minimize the occupants' exposure to formaldehyde, consider using SIPs that have no added formaldehyde in the OSB (*Structure: Measure 04—Engineered Lumber*).

Cost and Cost Effectiveness

| | | |
|---------|--------|--|
| BENEFIT | ★★★ | The cost of panelized walls, roofs and floors is more expensive initially than the cost of raw materials for conventional construction. However, the shorter construction time and the savings in site labor, material waste and clean-up fees may offset much, if not all, of the panels' cost. |
| COST | \$\$\$ | |

Remember, too, that SIPs are already insulated and sheathed, so their cost is favorable when compared to adding the insulation and sheathing on site.

Resources

- » **Structural Insulated Panel Association** is a trade association representing the SIP industry:
Tel. (253) 858-0272
www.sips.org
- » **Building Green's** website has SIP product reviews and information:
www.buildinggreen.com
- » **ACWMA's** Materials Database lists products that correspond with this measure:
www.multifamilygreen.org

RAISED HEEL TRUSSES

Specify Trusses with Raised Heels for Better Insulation

| WHO | KEY BENEFITS |
|--|--|
| <ul style="list-style-type: none"> ✓ Developer/PM Funder Policymaker ✓ Architect ✓ Builder Resident Building Manager | <ul style="list-style-type: none"> Health/IEQ Site/Community ✓ Energy Efficiency Water Efficiency ✓ Material Efficiency O&M ✓ Resident Satisfaction ✓ ENERGY STAR® |
| 06175: Wood Trusses | |

Recommendation

Where trusses are used, specify trusses with raised heels to accommodate increased insulation.

Description

Trusses designed to accommodate increased insulation at the perimeter of the building are called raised heel or energy heel trusses. The heel raises the height of the truss at the exterior-wall top plates so that the full depth of insulation can be installed at the building's perimeter. With conventional trusses, the perimeter intersection of the wall and roof framing often experiences increased heat loss since conventional trusses reduce insulation to less than 6 inches.

Some trusses are made from FSC-certified lumber (Structure: Measure 03—FSC-Certified Wood).

Benefits

Saves energy by eliminating the insulation weak spot along the entire perimeter wall associated with standard truss heels.

Application

Can be installed where conventional trusses are used. Like any truss, raised heel truss designs need to be specified from the manufacturer.

Design Details

As shown in the diagram, an energy heel raises a standard roof height several more inches to create room for additional insulation. The increased height may require small modifications to exterior soffit and trim details (for other recommendations related to energy-efficient framing

and insulation, see Planning & Design: Measure 11—ENERGY STAR® Certified Homes / Structure: Measure 05—Advanced Framing Design / Structure: Measure 09—Insulation / Systems: Measure 10—Advanced Ventilation Practices / Structure: Measure 12—Cool Roof).

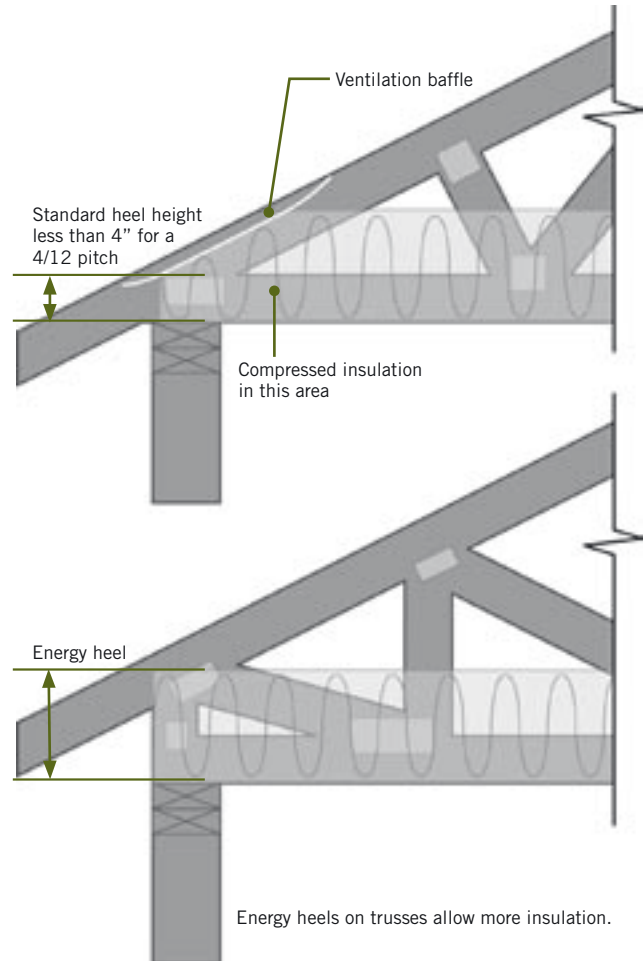

Code Considerations

There are no special code considerations for raised heel trusses or FSC-certified lumber.

Considerations for Residents

Raised heel trusses make homes more comfortable and reduce energy use because they allow for more attic insulation near the perimeter wall. This results in fewer hot/cold spots around the exterior walls.

Cost and Cost Effectiveness

| | |
|---------|--------|
| BENEFIT | ★★★ |
| COST | \$\$\$ |

Raised heel trusses cost the same as standard trusses in most cases.

Resources

Any truss maker can build raised heel trusses.

INSULATION

Recycled-Content Insulation Without Added Formaldehyde

| WHO | KEY BENEFITS |
|---|--|
| <ul style="list-style-type: none"> ✓ Developer/PM Funder Policymaker ✓ Architect ✓ Builder Resident Building Manager | <ul style="list-style-type: none"> ✓ Health/IEQ Site/Community ✓ Energy Efficiency Water Efficiency ✓ Material Efficiency O&M ✓ Resident Satisfaction ✓ ENERGY STAR® |
| 07850: Building Insulation | |

Recommendation

For wall and ceiling insulation, specify either formaldehyde-free fiberglass batt insulation, or 100% borate-based cellulose insulation (avoid ammonium sulfate-based products).

If specifying cellulose insulation, see the Design Considerations to choose between damp-spray and dry-blown.

Description

Fiberglass insulation with no added formaldehyde is widely available, and can be used anywhere that fiberglass batt is used. It costs the same as standard batt insulation, although there are currently fewer manufacturers. Typical recycled content ranges from 20% to 30%.

Cellulose insulation contains more than 75% recycled newsprint, does not have added formaldehyde, and insulates as well as high-density fiberglass batts (up to R-3.7 per inch thickness). Cellulose can be dry-blown into attic spaces, packed dry into walls, or damp-sprayed into wall assemblies using water-activated adhesives. Because of cellulose's ability to surround and seal cavities and voids, cellulose performs better thermally and acoustically than fiberglass batts. For shared-wall multifamily applications, cellulose can achieve good noise separation and fire ratings.

Benefits

Most fiberglass insulation contains urea formaldehyde-based binders that can offgas during and after installation (*for more about formaldehyde, see Finishes & Furnishings: Measure 09—Cabinets, Counters and Trim*). Even if there is no added formaldehyde, fiberglass is still a skin and respiratory irritant as well as a known carcinogen if the glass particles are inhaled in excessive quantities.

Wet-blown (or damp-spray) cellulose has significant advantages over fiberglass batts:

- » Surrounds pipes and fills gaps, reducing air movement and improving performance
- » Better at absorbing sound
- » Made of recycled newspaper and has no added formaldehyde
- » Meets the same fireproofing standards

Application

Fiberglass insulation with no added formaldehyde can be used wherever traditional batt insulation is used, including new construction and major renovation where studs will be exposed. Use cellulose in common walls to reduce noise transmission between units and in exterior walls to improve thermal and acoustic performance.

Design Details / Fiberglass

Fiberglass insulation without added formaldehyde is procured and installed the same as standard batt insulation. The only exception is that some brands do not use any binding agents; instead, the fiberglass strands are tightly wound to hold their shape. These products—for example, Miraflex from Owens Corning—are not recommended for walls in some instances because of lack of rigidity.

Design Details / Cellulose

SCHEDULING



The installation of cellulose insulation in walls needs to be carefully scheduled. Cellulose is installed later in the construction process than fiberglass, after all plumbing and wiring is completed. If the insulation is installed too early, then the insulation contractor will have to return to the site to add insulation where other subcontractors have removed it. When properly staged, cellulose can be installed in less time than traditional batt insulation.

MATERIALS



Avoid installing damp-spray insulation during wet months. Install drywall only after testing for 25% (maximum) moisture content. Only use cellulose treated with boric acid; avoid ammonium sulfate-treated cellulose insulation because of odor and corrosion issues. If moisture issues with cellulose are a concern, consider blowing dry cellulose into walls using a netting system shown in the photo below. This method typically increases costs by 10% above damp-spray cellulose due to increased labor for installing netting.



Cellulose insulation completely fills voids that would otherwise be difficult to insulate with fiberglass.

ACHIEVING PUBLISHED R-VALUES

Cellulose has an estimated R-value of 3.5–3.7 per inch. Here are some installation tips for achieving these R-values:

Make sure walls, ceilings and floors are properly prepared for cellulose installation. Having to run wire or adjust conduit after the insulation is in place is costly, and reduces the effective R-value if the insulation is not properly restored.

For ceilings, spread dry cellulose over ceiling joists or blow into tight cavities to increase ceiling R-value. It is important to maintain attic or ceiling ventilation pathways, especially in cathedral ceiling applications.

For dry-blown cellulose in walls, the installer should avoid excessive cellulose behind the netting as it may make it difficult to keep the drywall flat. To help keep the walls and ceilings flat, it is best to use 5/8-in. drywall.

For dry-blown cellulose in attics, install R-value markers every 8 ft (connected to the trusses) that visually show the depth needed to achieve the desired R-value.

Code Considerations

FIRE RATINGS

Fiberglass insulation meets fire code ratings. Cellulose insulation is treated with borates to meet the same fireproofing standards as fiberglass. Specify a cellulose insulation that has a Class 1 fire rating. The illustration below shows the construction assembly needed for a 2-hour fire rating; 1-hour fire ratings are achieved with standard 2x4 construction.

STC RATINGS

Cellulose insulation can be more effective than fiberglass batts at reducing airborne sound transmission as well as noise from plumbing and other sources. U.S. GreenFiber, the manufacturer of Cocoon cellulose insulation, achieved a sound transmission coefficient (STC) rating of 51 in a single 2x4 wall using wet-blown cellulose insulation. Thicker wall assemblies, with double row staggered 2x4 wood studs covered by a double layer of 5/8-in. gypsum board, achieved an STC rating of 61 in laboratory tests.

Considerations for Residents

The U.S. EPA considers formaldehyde to be a “hazardous air pollutant.” The EPA is concerned about formaldehyde’s role in aggravating asthma and other respiratory illnesses. Reducing occupants’ exposure to formaldehyde by installing cellulose or fiberglass insulation with no added formaldehyde helps create a healthier home.

Also, better acoustics and sound dampening qualities of cellulose make the indoor environment more pleasant. The added density and sealing ability of cellulose also saves energy through reduced heating and cooling bills.

Cost and Cost Effectiveness

| | | |
|----------------|--------|--|
| BENEFIT | ★★★ | Fiberglass insulation with no added formaldehyde is available from numerous manufacturers at competitive prices. |
| COST | \$\$\$ | |

In the San Francisco Bay Area, cellulose typically costs 20% to 40% more than standard fiberglass insulation. Prices may be somewhat lower for large multifamily projects because of labor efficiencies.

Resources

- » **Building Green**, publisher of *Environmental Building News*, has a host of resources on cellulose insulation: www.buildinggreen.com
- » **Cellulose Insulation Manufacturers Association:** www.cellulose.org
- » **ACWMA's** Materials Database lists products that correspond with this measure: www.multifamilygreen.org

DURABLE SIDING

Select Environmentally Preferable, Long-Lasting Siding

| WHO | KEY BENEFITS |
|---|--|
| <ul style="list-style-type: none"> ✓ Developer/PM ✓ Funder ✓ Policymaker ✓ Architect ✓ Builder ✓ Resident ✓ Building Manager | <ul style="list-style-type: none"> ✓ Health/IEQ ✓ Site/Community ✓ Energy Efficiency ✓ Water Efficiency ✓ Material Efficiency ✓ O&M ✓ Resident Satisfaction ENERGY STAR® |
| 07460: Siding Materials | |

Recommendation

Select siding materials that are durable and have minimal impact on the environment.

Durable products include stucco, fiber cement, composite wood, stone, and brick or brick veneer.

Description

In addition to its aesthetic function, siding protects a building's exterior walls from wind, sunlight, pests and water.

Two popular forms of siding are not recommended in green building because of environmental concerns:

Vinyl siding. Vinyl is a nonrecyclable product that poses a future landfill burden. The environmental consequences of vinyl production also make the product problematic to recommend (*for more about vinyl manufacturing and disposal, see Finishes & Furnishings: Measure 06—Natural Linoleum*).

Conventional wood siding. High maintenance costs and detrimental harvesting practices make wood siding less desirable than other options. However, certain wood siding products are environmentally sound: certified wood siding, for example, can be purchased, guaranteeing that the trees came from well-managed forests (*Structure: Measure 03—FSC-Certified Wood*). Also, some suppliers offer reclaimed wood siding from old buildings, telephone poles, or river and lake bottoms. Wood can hold up extremely well with proper maintenance, but other options are available that are more durable and need less maintenance.

Preferable siding options include fiber cement, stucco, composition (hardboard), and brick or stone. These products are more durable than wood, easier to maintain, and are made with sustainable materials.

Fiber-cement siding is gaining popularity as a safe, durable product. It is made of portland cement, sand and cellulose fibers.

Stucco is a common siding material in California. It is made of sand, water and cement. Today some stucco has an acrylic finish.

Composition siding (or hardboard) looks and performs like wood siding. It is made with wood fibers from industrial process waste or fast-growing tree species.

Brick, stone and brick or stone veneers are also good choices. Bricks are often used in new construction to give the façade a classic look.

Benefits

Durable siding materials protect a building from premature deterioration. Longer life spans mean less waste in landfills and lower replacement costs.

Application

Applicable to any exterior wall of a building.

Design Details

Ensuring proper weatherproofing and water shedding under the siding will increase the siding's and the building's life (*Planning & Design: Measure 12—Moisture Shedding and Mold Avoidance*).

Fiber-cement siding has the best features of wood siding (in terms of workability and appearance), but it doesn't split or crack, it holds paint longer, and is more moisture resistant. Colors are integral in the product, so chips don't need repainting. In addition, it is fire and termite resistant.

It is available in shingles, planks, and 4x8, 4x9 and 4x10 sheets. It comes with either a flat finish or a textured finish to mimic wood or stucco. Fifty-year warranties on fiber-cement siding products are common.

Fiber-cement and composition siding are installed exactly like wood siding and can be cut with a carbide or diamond-tipped saw blade, shaper shears, or a guillotine cutter. Dust protection and control are required when cutting with a circular saw.

Stucco is durable, fire resistant, and made from readily available materials. In a traditional stucco application, building paper and wire mesh is attached to the sheathing and studs of the house. Two or three coats of various stucco mixtures are then applied over the wire mesh. Stucco may require some ongoing maintenance, it is susceptible to moisture, and it may develop some cracks as the building settles. Proper overhangs and moisture shedding details can help protect stucco.

Composition siding will not crack, split or warp and holds paint better than solid wood siding. Specifying high quality materials and conducting proper maintenance are critical, however, to avoid early product failure (some low-end composition siding products have had performance issues). For information about installation, refer to fiber-cement siding above.

Brick and brick veneer siding is durable, long lasting, low maintenance and fire resistant. Some local suppliers carry salvaged bricks and stone from demolished buildings.



Fiber-cement siding being installed at the Fruitvale Habitat for Humanity project in Oakland.

Code Considerations

Some siding materials may not be allowed by building departments. Wood or other siding products may or may not meet local fire and other code requirements. Check with local jurisdictions and product manufacturers.

Considerations for Residents

None.

Cost and Cost Effectiveness

| | | |
|----------------|--------|--|
| BENEFIT | ★★★ | Specifying a high quality, durable siding will reduce the risk of product failure, saving money. |
| COST | \$\$\$ | |

MAINTENANCE

- » Fiber-cement and composition siding need to be repainted every 5 to 10 years, but otherwise repairs are generally minor. Costs of fiber-cement and composition siding are comparable.
- » Cracks in stucco may require more frequent maintenance than fiber-cement or composition siding, but are fairly easy to fill. In the Bay Area, stucco typically costs the same as fiber cement.
- » Brick and stone have high material and installation costs but virtually no maintenance costs except where graffiti is a problem.

Resources

- » *Environmental Building News*, July 1997, article on siding options: www.buildinggreen.com
- » **ACWMA's** Materials Database lists products that correspond with this measure: www.multifamilygreen.org

DURABLE ROOFING

Use Long-Lasting Roofing Materials on Pitched Roofs

| WHO | KEY BENEFITS |
|---|---|
| <ul style="list-style-type: none"> ✓ Developer/PM Funder Policymaker ✓ Architect ✓ Builder Resident ✓ Building Manager | <ul style="list-style-type: none"> ✓ Health/IEQ Site/Community ✓ Energy Efficiency Water Efficiency ✓ Material Efficiency ✓ O&M ✓ Resident Satisfaction ENERGY STAR® |
| 07300: Roofing Materials | |

Recommendation

Specify roofing materials that will last a long time and pose minimal safety concerns. Forty- to fifty-year asphalt composition shingles, tile, slate, fiber cement and metal are examples of safe and durable roofing materials.

Also consider cool-roof products that minimize rooftop temperatures (*Structure: Measure*

12—Cool Roof).

Description

Short-lived roofing materials result in more waste going to landfills and more money spent on roof replacement. In extreme cases, early failure of a roofing material can damage a building and require costly repairs.

Avoid cedar and wood-shake shingles for several reasons: fire hazard, short life span, high maintenance, and depletion of forests due to the harvesting of trees.

Durable roofing materials include these products:

Asphalt composition shingles come in various quality levels, designated by the product's life expectancy. Twenty- to fifty-year shingles are available. Products with 40- to 50-year ratings are superior because of better backing materials and asphalt coatings. Asphalt does have environmental downsides: it is made with petroleum products, a nonrenewable resource, and asphalt shingle recycling is currently not common practice. However, some manufacturers offer asphalt shingles with recycled content.

Tile is another durable material, with clay and fiber-cement tiles the most commonly installed types. Some tiles may also qualify as cool roof products (*Structure: Measure 12*). Clay tiles are generally more durable than cement, and clay is a readily available raw material. Fiber-cement tiles contain portland cement, which is not as environmentally benign as clay (*for information about the environmental impacts of cement production, see Structure: Measure 02—High-Volume Flyash in Concrete*). Tiles are sometimes reused, or can be ground up and used for other purposes.

Slate roofing shingles are durable and relatively environmentally benign. Slate is often recovered from older buildings and reused.

Sheet metal products are becoming more popular for roofing. Some products integrate photovoltaics directly into the metal roof, thus reducing the cost of the solar electric system (there's no need to install mounting brackets). Metal roofs come in varying thickness and colors. Most steel metal roofs can be recycled when removed.



Durable roofing tiles such as these look like wood shake but will last 40 years or more.

Other environmentally sound roofing products are available, made from recycled, alternative or salvaged materials. For example, some manufacturers make shingles out of recycled plastic resins. It's important to check the fire rating and warranty period of any roofing product.

Benefits

Durable roofing materials reduce waste and decrease replacement costs. They also protect a building from moisture better than low-cost options.

Application

Applicable on any pitched roof. In hotter climates, consider cool roof products (*Structure: Measure 12*). If installing photovoltaics, consider a standing-seam metal roof (*Systems: Measure 15—Onsite Electricity Generation*).

Design Details

Proper flashing details will help increase the roof and building life (*Planning & Design: Measure 12—Moisture Shedding and Mold Avoidance*). Insulating the roof and using a radiant barrier will increase energy efficiency (*Structure: Measure 09—Insulation / Structure: Measure 12—Cool Roof*).

Code Considerations

Some roofing materials—such as wood shake shingles—may not be allowed by building departments. Alternative or recycled content products may or may not meet local fire and other code requirements. Check with local jurisdictions and manufacturers.

Considerations for Residents

No noticeable effect on occupants.

Cost and Cost Effectiveness

| | | |
|----------------|--------|--|
| BENEFIT | ★★★ | Asphalt shingles are the least expensive roofing material. The products with the lowest lifetime ratings (20 years) are very inexpensive but their quality can be very poor. Specifying a higher quality, longer life asphalt will reduce installation and replacement costs. Higher quality products have heavy duty backing, which minimizes tearing and ripping during installation and reduces the risk of product failure during its expected lifetime. |
| COST | \$\$\$ | |

Tile, slate and metal roofing can be considerably more expensive than asphalt shingles, but the lifecycle cost, which takes into account the reduced replacement needs, can make them more attractive.

Fiber-cement roofing is more expensive than shingles, but less than tile.

Alternative and composite roofing materials cover a vast range of prices, but most are less expensive than tile.

Resources

- » **Building Green**, publisher of *Environmental Building News*, has an article about roofing materials (Vol. 4, No. 4), and lists roofing products: www.buildinggreen.com
- » **ACWMA's** Materials Database lists products that correspond with this measure: www.multifamilygreen.org

COOL ROOF

Reduce the Heat Island Effect with Cool Roofing Materials

| WHO | KEY BENEFITS |
|---|--|
| <ul style="list-style-type: none"> ✓ Developer/PM ✓ Funder ✓ Policymaker ✓ Architect ✓ Builder ✓ Resident ✓ Building Manager | <ul style="list-style-type: none"> ✓ Health/IEQ ✓ Site/Community ✓ Energy Efficiency ✓ Water Efficiency ✓ Material Efficiency ✓ O&M ✓ Resident Satisfaction ✓ ENERGY STAR® |
| 07330: Roof Coverings | |

Recommendation

For low-slope or flat-roof buildings in urban areas or where air conditioning is necessary, use cool roofing materials.

Cool roof materials have a reflectance greater than 0.75 and emittance greater than 0.70. (An exception is concrete and clay tile roofing materials, where reflectance must be greater than 0.75, and emittance must be greater than 0.40).

Description

The roof generally receives more direct sunlight than any other part of the building. Dark roof surfaces absorb sunlight and reradiate it as heat to the surrounding air. In dense urban areas, this creates a “heat island effect,” increasing outside air temperatures by as much as 5°F during the hottest time of the day (*for more about the heat island effect, see Planning & Design: Measure 09—Cool Site*).

Heat absorbed by the roof is also transferred inward, increasing interior temperatures and driving up cooling loads.

“Cool roofs” are roofing systems designed to minimize rooftop temperatures by:

- » Reflecting a significant portion of the sun’s rays away from the roof (high solar reflectance or albedo); and
- » Limiting the amount of heat stored by the roofing material (high emittance).

Total solar reflectance or albedo is the ability of a material to reflect heat away from its surface. Reflectivity is rated as compared to a perfect mirror surface. A reflectivity of 0.70, therefore, is 70% as reflective as a mirror.

Emittance is the ability of a material to shed heat. High emittance values mean that heat is shed quickly, thus keeping surface temperatures low. Emittance is rated from 0 to 1.0, with higher numbers indicating greater emittance.

A white roof, although highly reflective, is not necessarily a cool roof. White surfaces can get quite hot if they have low emittance. White sand beaches, for example, are highly reflective but store heat and can get very hot.

Cool roof products come in numerous varieties and colors. The two main types are single-ply membrane and liquid-applied products.



Cool roof sheathing being installed on a flat roof.

Single-ply membranes are rolls of smooth, white plastic materials that are applied over the finish roof. The seams are welded to create a continuous heat barrier. Major types of sheathing materials are polyvinyl chloride (PVC), chlorinated polyethylene (CPE), chlorosulfonated polyethylene (CPSE), ethylene propylene diene monomer (EPDM), and thermoplastic polyolefin (TPO). From a materials perspective, these plastic products are not necessarily the greenest option. When choosing a roofing material, however, it is important to balance the energy savings from reducing air-conditioning loads (or eliminating air conditioning) against the material’s impact.

Liquid-applied products are white and can be applied to traditional asphalt cap sheets, modified bitumen and other substrates. Products include elastomeric coatings, polyurethane coatings, acrylic coatings and paint (on metal or concrete).

This table provides total solar reflectance and emittance values for common roof systems.

REFLECTANCE AND EMITTANCE OF VARIOUS ROOFING MATERIALS

| ROOFING MATERIAL | TOTAL SOLAR REFLECTANCE | EMITTANCE |
|---|-------------------------|------------|
| Liquid-Applied Reflective Coatings | 0.30–0.78 | 0.42–0.91 |
| Metal Roofing | | |
| Bare Galv. Steel or Aluminum | 0.61 | 0.04–0.25 |
| White (factory-applied coating) | 0.59–0.67 | 0.85 |
| Single-Ply Roof Membrane | | |
| Black EPDM | 0.06 | 0.86 |
| White EPDM | Up to 0.81 | Up to 0.92 |
| Paint | | |
| Aluminum | 0.80 | 0.40 |
| White | 0.85 | 0.96 |
| Asphalt Shingles | | |
| Black | 0.03–0.05 | 0.91 |
| Medium Brown | 0.12 | 0.91 |
| Light Brown | 0.19–0.20 | 0.91 |
| Green | 0.16–0.19 | 0.91 |
| Grey | 0.08–0.12 | 0.91 |
| Light Grey | 0.18–0.22 | 0.91 |
| White | 0.21–0.31 | 0.91 |
| Source: LBNL Cool Roofing Materials Database, http://eetd.lbl.gov/coolroof | | |

Benefits

In hotter climates and for buildings with air conditioning, cool roofs can lower the roof temperature by 40°F or more. This saves money by reducing air-conditioning loads, and in some cases eliminating the need for air conditioning. Cool roofs in urban environments also help reduce the heat island effect.

Cool roofs may also extend the roof's life. They expand and contract less than dark materials, and therefore don't usually deteriorate as quickly.

Application

Cool roofs are most applicable to hotter climates such as eastern Alameda County, and to urban areas where it is desirable to reduce the heat island effect. Within those regions, cool roofs are applicable to all multifamily housing projects.

Many affordable housing and multifamily projects have more than one roof type. Select appropriate cool roof technologies for each surface: reflective coatings or membranes on flat roof surfaces, and metal or tiles on sloped areas (for projects that will be installing asphalt shingles or other non-cool roof products, see Structure: Measure 11—Durable Roofing).

Design Details

RADIANT BARRIERS

A radiant barrier on the roof sheathing is an integral component of a cool roof system. Install radiant barriers with the foil surface facing down toward the attic. This reduces radiant heat gain to ducts and insulation located below the radiant barrier.

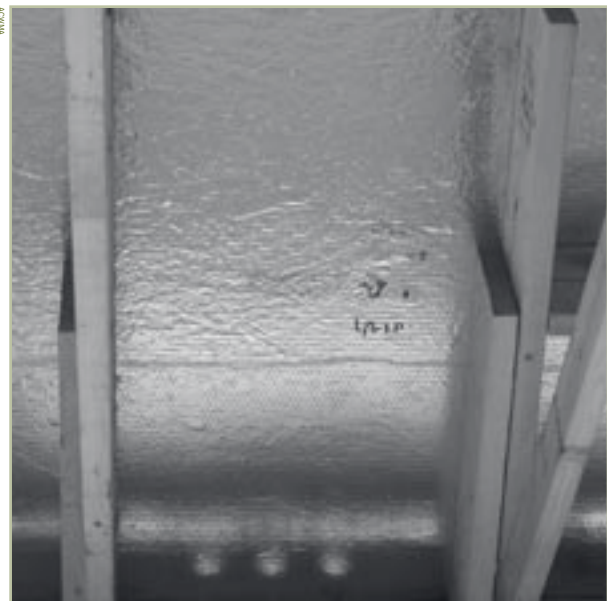

Radiant barrier sheathing is placed in the attic with the foil face toward the interior.

INTEGRATED DESIGN

Consider cool roofs early in schematic design to maximize their benefits. It may be possible to downsize or eliminate the air-conditioning system if the design includes a cool roof combined with other energy-saving features, such as overhangs, increased insulation, high-performance windows and proper building orientation (Planning & Design: Measure 03—Building Placement and Orientation / Planning & Design: Measure 11—ENERGY STAR® Certified Homes / Structure: Measure 09—Insulation / Structure: Measure 13—High-Performance Windows / Systems: Measure 07—Avoid Air Conditioning).

Code Considerations

California's Title 24 gives credit for cool roofs, which can help with compliance. The cool roof criteria in the Recommendation section of this measure is the same as the Title 24 requirements.

Radiant barriers are required in California's hotter climates, including eastern Alameda County.

Local jurisdictions may not allow light-colored roofs on sloped sections near roadways due to glare and other visibility concerns. In these areas, use materials with the highest reflectivity and emittance possible under the local code.

Considerations for Residents

Cool roofs save money by reducing cooling loads during summer months.

Cost and Cost Effectiveness

| | | |
|----------------|---------|--|
| BENEFIT | ★★★ | For flat roofs with an asphalt cap sheet or modified bitumen, cool roof coatings typically add \$0.75 to \$2.00 per square foot. |
| COST | \$ \$\$ | |

High reflectance single-ply cool roof membranes cost the same as darker membranes. Look for light-colored membranes that have high reflectivity (all have high emittance).

Radiant barrier sheathing adds a few cents per square foot, but typically pays for itself in reduced air conditioning costs within a few months.

All cool roof materials require some cleaning to keep their performance levels high. Flat roofs may need pressure washing annually to clean the surface. Sloped roofs require less maintenance since they shed dirt and other particulates relatively well.

Life spans range from 5 to 30 years or more, depending on material chosen.

Resources

- » **Cool Roof Rating Council** maintains a listing of cool roof products: www.coolroofs.org
- » **California Energy Commission** has a website for cool roof research: www.consumerenergycenter.org/coolroof
- » **California Energy Commission** Title 24 Residential and Nonresidential manuals for compliance with the energy standards of California can be found at: www.energy.ca.gov/title24
- » **Oak Ridge National Laboratory's** Radiation Control Calculator can help estimate the potential savings for cool roofs. At the website, click on "interactive calculators" and run the "radiation control calculator": www.ornl.gov/roofs+walls
- » **Lawrence Berkeley National Laboratory (LBNL)** maintains a Cool Roofing Materials Database: <http://eetd.lbl.gov/coolroof>
- » **LBNL's Heat Island Group** has useful information on the heat island effect and cool roofs: <http://eetd.lbl.gov/HeatIsland>
- » **Building Green**, publisher of *Environmental Building News*, has cool roof information: www.buildinggreen.com
- » **Collaborative for High Performance Schools (CHPS)** has good information on cool roofs in Volume II—Design: www.chps.net
- » **ACWMA's** Materials Database lists products that correspond with this measure: www.multifamilygreen.org

HIGH-PERFORMANCE WINDOWS

Specify High-Performance Glazing and Insulated Windows

| WHO | KEY BENEFITS |
|---|--|
| <ul style="list-style-type: none"> ✓ Developer/PM ✓ Funder Policymaker ✓ Architect ✓ Builder Resident Building Manager | <ul style="list-style-type: none"> ✓ Health/IEQ Site/Community ✓ Energy Efficiency Water Efficiency Material Efficiency ✓ O&M ✓ Resident Satisfaction ✓ ENERGY STAR® |
| <p>08500: Windows, 08800: Glazing</p> | |

Recommendation

Anticipate 2005 changes to California’s Title 24 energy code by selecting high-performance glazing and insulated windows for all building types.

All windows should have U-factors of 0.47 or less (in accordance with the expected 2005 Title 24 requirements for four-story and taller residential buildings. *Note:* ACWMA recommends that ALL multifamily buildings meet this U-factor standard).

Meet all applicable standards for relative solar heat gain (or SHGC) values for each building type, as shown below:

| WINDOWS | ZONE 3 (COASTAL) | | ZONE 12 (INLAND) | |
|--|------------------|-------|------------------|-------|
| | Non-North | North | Non-North | North |
| U-factor | 0.47 | | 0.47 | |
| Relative Solar Heat Gain or SHGC by orientation | | | | |
| 0–10% WWR | 0.41 | 0.61 | 0.36 | 0.49 |
| 11–20% WWR | 0.40 | 0.61 | 0.36 | 0.49 |
| 21–30% WWR | 0.31 | 0.61 | 0.31 | 0.40 |
| 31–40% WWR | 0.26 | 0.55 | 0.26 | 0.40 |
| WWR = window-wall ratio | | | | |

In most cases, meeting these recommendations requires using low conductivity frames and low-emissivity (low-e) glazing on all windows. The exception is windows on a passive solar building; in that case, to allow the maximum amount of heat to enter the space, south-facing windows should not have low-e glazing (*Systems: Measure 01—Passive Solar Heating / Systems: Measure 02—Thermal Mass Flooring*).

Description

Windows generally make up a significant fraction of a multifamily unit’s exterior wall. In the summer, windows can allow unwanted heat into the unit, and in the winter, they can account for as much as 25% of heat loss. High-performance windows help control heat gain and loss.

When specifying windows, it’s important to understand these terms:

- » **U-factor** (the inverse of R-value) is a measure of heat transferred by the entire window (frame, sash and glass) either into or out of the building. The lower the U-factor, the more comfort the window will provide on cold days.
- » **Solar heat gain coefficient (SHGC)** is a measure of the solar energy entering the building through the entire window. A lower SHGC will reduce air-conditioning costs and provide more comfort on hot days.
- » **Relative solar heat gain** is the SHGC value of windows, corrected for the wall orientation.

High-performance windows can achieve R-values (the inverse of U-factor) of 2 to 3 compared to R-1 for standard single-pane windows. In comparison, a wall achieves R-13 or more, making windows the main weak spot for heat loss in any building.

WINDOW CHARACTERISTICS

High-performance windows minimize heat gain and loss through these four methods:

Insulated glazing system: Dual-pane windows insulate better than single-pane. In most instances (but not all), dual-pane windows are required by Title 24.

Spectrally selective coatings: Low-e coatings block the sun’s heat energy from entering a building. They can also reduce the loss of heated indoor air in the winter.

Frame materials: Low-conductivity frames insulate better. Wood, vinyl, composite and fiberglass all perform better than aluminum. If aluminum frames are selected, then a product with thermal breaks between the interior and exterior panes of glass is strongly recommended.

Tight installation: Sealing around framing and other gaps between the window frame and exterior wall minimizes air leaks. Caulk, foam and weatherstripping ensure a tight installation that will prevent drafts.

Gas fill: Some high-performance windows have a low-conductivity gas, usually argon, encapsulated between the two panes of glass. This increases the insulation level of windows. However, it’s not certain that the gas will remain in the window throughout the window’s life expectancy; the gas is invisible, so it may escape without notice. With the advent of low-e coatings, the benefits of gas-filled windows have somewhat diminished and they are now much less common.

Benefits

Low-e coatings reduce heating and cooling needs, saving energy and making the home more comfortable. They also reduce the fading of interior furnishings and materials by blocking ultraviolet radiation.

Insulated windows reduce condensation on windows, which helps prevent water damage and potential for mold growth.

High-performance windows can help achieve ENERGY STAR® certification (*Planning & Design: Measure 11*).

Application

Applicable to all projects.

Design Details

Window placement greatly affects energy consumption and comfort. Limiting windows on the west and east walls reduces the amount of direct sunlight entering the building. Proper overhangs over south-facing windows will provide shade during hot summer months. Windows on the north walls provide diffuse light, which is often good for daylighting (*Planning & Design: Measure 03—Building Placement and Orientation*).

Integrated design. Windows can also affect mechanical system sizing. It may be possible to downsize or even eliminate the air-conditioning system if wall insulation is increased and high-performance windows are placed optimally (limited east- and west-facing windows, and south-facing windows coupled with overhangs).

Passive solar heating. South-facing windows can aid in passive solar heating. If the design incorporates passive heating or cooling, the recommended U-factor or SHGC may differ from a standard design. Computer modeling can help determine the best glazing options (*Systems: Measure 01—Passive Solar Heating / Systems: Measure 07—Avoid Air Conditioning*).

Noise reduction. For projects located on noisy streets or in other areas where noise is a problem, it may be beneficial to install special sound-rated windows that have a stiffer or thicker pane of glass, larger air gaps or better gaskets.

Durability. Poorly detailed windows can allow water to enter the wall cavity, creating conditions for mold to grow. Ensure that windows are properly flashed and sealed (*Planning & Design: Measure 12—Moisture Shedding and Mold Avoidance*).

Code Considerations

TITLE 24 REQUIREMENTS

Title 24 requires high-performance windows. The following table shows minimum requirements for Alameda County's two climate zones.

TITLE 24 WINDOW REQUIREMENTS FOR BUILDINGS IN ALAMEDA COUNTY (VALID UNTIL 2005 STANDARDS TAKE EFFECT)

| | ZONE 3 (COASTAL) | ZONE 12 (INLAND) |
|--|-----------------------|-----------------------|
| Low-rise residential (≤3 stories) | | |
| U-factor | ≤0.75 | ≤0.65 |
| SHGC | Not required | 0.40 |
| High-rise residential (>3 stories) | | |
| U-factor | 0.49 | 0.49 |
| SHGC | Varies by orientation | Varies by orientation |

NFRC ENERGY PERFORMANCE RATINGS

Factory-made windows typically have a National Fenestration Rating Council (NFRC) label showing the product's U-factor and SHGC. Although a window may also have other labels, the NFRC label is the best source of energy performance data. The label is useful for comparing energy loss between window types, frame materials, glass coatings, brands and styles (*for more about the NFRC label, see the Resources section below*).



A sample NFRC label found on factory-made windows.

Many smaller window shops make their own windows and do not get NFRC ratings. For these windows, Title 24 mandates the use of conservative default values based on frame type, even though the window's actual performance may be much higher. For the purpose of meeting the window recommendations in ACWMA's Guidelines, ask manufacturers for estimated NFRC values if the window doesn't have an NFRC label. Note, however, that these estimated values cannot be used in Title 24 calculations.

Considerations for Residents

High-performance windows typically will reduce energy bills and create a more comfortable home. Special sound-rated windows can reduce noise transmission.

Cost and Cost Effectiveness

| | | |
|---------|--------|--|
| BENEFIT | ★★★ | When comparing window costs, be sure to consider the long-term savings and increased comfort provided by high-performance windows. |
| COST | \$\$\$ | |

Vinyl windows and thermally broken aluminum windows are both somewhat more expensive than standard aluminum windows, costing about \$1 more per square foot. Fiberglass, wood and composite windows are considerably more expensive than vinyl or metal.

Low-e coatings add about \$0.30 to \$0.50 per square foot and are definitely cost effective, achieving a payback of three years or less.

Resources

- » **Efficient Windows Collaborative** provides valuable information about selecting energy-efficient windows: www.efficientwindows.org
- » **ENERGY STAR®** has information on high-performance windows: www.energystar.gov (click on "Products" and look for windows)
- » **NFRC** provides details about their window rating program: www.nfrc.org

This section addresses five categories of multifamily residential building systems:

- » Heating, ventilation and air conditioning (passive and mechanical)
- » Daylighting and electric lighting
- » Appliances and other energy-using equipment
- » Onsite energy generation
- » Plumbing fixtures and systems

The recommended measures in this section provide two main benefits: energy efficiency and better indoor environmental quality. Improving energy efficiency and using renewable energy sources are effective ways to reduce the risk of energy supply interruptions, improve outside air quality, and reduce the impacts of global warming.

In green residential buildings, energy efficiency and indoor environmental quality are complementary goals. They save money for building owners and residents year after year. Buildings with high-efficiency heating and cooling equipment (*Systems: Measure 03 / Systems: Measure 08*) tend to be more comfortable. Effective duct systems (*Systems: Measure 09*) and advanced ventilation practices (*Systems: Measure 10*) provide better indoor air quality. Daylit spaces (*Systems: Measure 12*) can save electric lighting energy and make a home more pleasant.



SYSTEMS

BENEFITS

This table lists the Guidelines' Systems measures, and shows the primary benefits of each (see the individual measures for details).

| MEASURE | BENEFITS | | | | | | | |
|--|--|----------------|---|------------------|--|-----|--|--------------|
| | Health/IEQ | Site/Community | Energy Efficiency | Water Efficiency | Material Efficiency | O&M | Resident Satisfaction | ENERGY STAR® |
| 01 Passive solar heating | ✓ | | ✓ | | ✓ | ✓ | ✓ | ✓ |
| 02 Thermal mass flooring | ✓ | | ✓ | | ✓ | ✓ | ✓ | ✓ |
| 03 High-efficiency heating | ✓ | | ✓ | | | ✓ | ✓ | ✓ |
| 04 Radiant hydronic space heating | ✓ | | ✓ | | | ✓ | ✓ | ✓ |
| 05 Solar water heating | | | ✓ | | ✓ | ✓ | ✓ | ✓ |
| 06 High-efficiency water heating | ✓ | | ✓ | ✓ | | ✓ | ✓ | ✓ |
| 07 Avoid air conditioning | ✓ | | ✓ | | | ✓ | ✓ | ✓ |
| 08 High-efficiency A/C with advanced refrigerant | | | ✓ | | ✓ | ✓ | ✓ | ✓ |
| 09 Duct effectiveness | ✓ | | ✓ | | | ✓ | ✓ | ✓ |
| 10 Advanced ventilation practices | ✓ | | ✓ | | | ✓ | ✓ | ✓ |
| 11 Garage ventilation | ✓ | | ✓ | | | ✓ | ✓ | ✓ |
| 12 Daylighting | ✓ | | ✓ | | | ✓ | ✓ | |
| 13 High-efficiency lighting | ✓ | | ✓ | | ✓ | ✓ | ✓ | ✓ |
| 14 Light pollution reduction | | ✓ | ✓ | | | | ✓ | |
| 15 Onsite electricity generation | ✓ | ✓ | ✓ | | | ✓ | ✓ | |
| 16 Elevators | | ✓ | ✓ | | | ✓ | | ✓ |
| 17 ENERGY STAR® appliances | | | ✓ | ✓ | | ✓ | ✓ | |
| 18 Central laundry | ✓ | | ✓ | ✓ | ✓ | ✓ | ✓ | |
| 19 Water-efficient fixtures | | | ✓ | ✓ | | ✓ | ✓ | |
| EXPLANATION OF BENEFITS | Health/IEQ: Reduces indoor pollutants, promotes better indoor environmental quality, and/or provides opportunities for improved public health. | | Site/Community: Protects land, water and air on and near site from pollution or other environmental damage, uses municipal infrastructure more efficiently by redeveloping building or site, and/or provides important and needed amenities for the surrounding community. | | Energy Efficiency: Reduces building energy consumption. | | Water Efficiency: Reduces water use in building and/or on site. | |
| | Material Efficiency: Reduces, reuses and/or recycles materials that might have otherwise ended up in landfills, reduces materials needed to construct or operate the building, and/or uses materials produced in a way that minimizes environmental damage. | | O&M: Increases building's durability, and/or reduces operating and maintenance expenses. | | Resident Satisfaction: Saves residents' money and/or improves residents' quality of life. | | ENERGY STAR®: Helps achieve ENERGY STAR® for Homes certification. | |

KEY CONSIDERATIONS

INTEGRATED DESIGN

A few of these measures, such as ENERGY STAR® appliances and water-efficient fixtures—could be treated as independent strategies that can be added to a project at any stage in its development. But the majority are closely tied to other recommended measures in these Guidelines and should be evaluated as part of an integrated design process. Measures such as daylighting (*Systems: Measure 12*), passive solar heating (*Systems: Measure 01*) and eliminating air conditioning (*Systems: Measure 07*) depend heavily on early decisions regarding orientation, building massing, glazing location and area, wall and roofing thickness, and insulation.

Integrated design involves careful planning and evaluation, which may add first costs. To maximize this design-time investment, look for synergies with other green measures, with the goal of reducing costs in some areas to pay for other upgrades. For example, if a building is designed with energy-efficient features such as increased insulation, air sealing, high-performance windows and high-efficiency duct systems, it may be possible to install smaller, more efficient heating systems, and to eliminate or downsize mechanical cooling systems.

COST

Some of the recommended Systems measures offer quick paybacks or cost no more upfront than conventional multifamily housing design; these include light pollution reduction, fluorescent lighting, gearless elevators in mid-rise buildings, low-flow fixtures and some ENERGY STAR® appliances. Other measures may increase first costs, either because of added design time or higher equipment costs, but save money in other areas. For example, eliminating or downsizing air conditioning systems will more than pay for most window and overhang upgrades.

Incentives are available for environmentally preferable onsite generation systems. For market-rate housing, the payback on photovoltaic systems is about 8 to 15 years. In some instances, affordable housing developers can acquire tax credits and incentives to cut the payback periods in half.

SPECIALIZED EXPERIENCE

To successfully incorporate some of the recommended Systems measures, it may be necessary to seek designers and subcontractors with specific expertise. For example, the principles of passive solar design are generally understood by most architects, but many are inexperienced with the required details; consulting an experienced passive solar designer will help ensure that the building is comfortable and performs as intended. Similarly, onsite electricity generation and solar water heating require designers and installers with proven expertise.

LIGHT ENERGY SYSTEMS



LIGHT ENERGY SYSTEMS

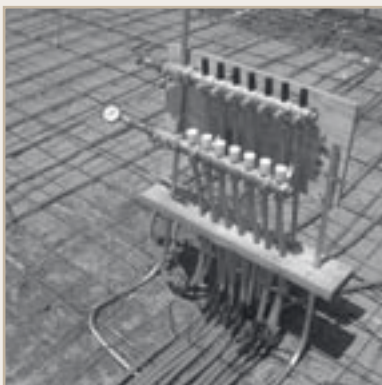

Radiant hydronic in-floor heating can be very energy efficient and comfortable. Compared to forced air systems, radiant heat results in less dust and fewer irritants in the breathing zone.

ROLES AND RESPONSIBILITIES

- » **Policymaker and building official.** Keep up-to-date on changes in energy efficiency practices and codes. For example, changes to the Title 24 standard will go into effect in 2005, with more stringent requirements in some cases. Encourage early adoption of expected changes to help make these transitions more effective and trouble-free in your community.
- » **Developer and project manager.** Support an integrated design process and put extra upfront effort into design to help ensure that you are creating a healthy, durable, energy-efficient building.
- » **Funder.** Seek ways to fund worthwhile measures that may have higher upfront costs or longer paybacks, such as onsite electricity generation. Obtain assistance (sometimes available for free) from utilities or other organizations that promote energy efficiency and renewable energy, such as Cooperative Community Energy for photovoltaics and PG&E's Pacific Energy Center for daylighting.
- » **Architect.** Work closely with mechanical and electrical engineers and other design team members to ensure that architectural strategies and systems strategies enhance each other to achieve the project's green goals. Bring on experts as needed for specialized issues such as passive solar design.
- » **Builder.** Do not substitute products, appliances or equipment without the project manager's approval. Make every effort to ensure that subcontractors are providing the highest quality work, that they understand the project's goals, and that they are aware of the client's commitment to green building.
- » **Building manager.** Understand and follow the recommended operation and maintenance procedures to ensure that the building remains as energy efficient and healthy as originally intended. Educate residents about their home's green features. If a unit is designed for passive solar heating, for example, it's important to explain to residents that their actions can affect their home's comfort and energy use; a throw rug on a mass floor, for instance, can reduce the effectiveness of the passive solar design.

FOCUS ON SYSTEMS: Johnson Creek Commons

The Johnson Creek Commons project in Portland, Oregon, combined a green retrofit of an aging 15-unit complex with the development of a new duplex. As part of the retrofit, electric resistance baseboard heating was replaced with efficient radiant cove heaters, energy-efficient appliances were installed, and incandescent lights were replaced with compact fluorescents in kitchens and bedrooms. These measures, combined with envelope upgrades such as increased insulation, weatherstripping, and high-performance windows, cost \$43,942, with an estimated payback of only 2.5 years. The new duplex was designed from the start with many of these energy efficiency features.

To learn more about this project, see the Johnson Creek Commons case study.

PASSIVE SOLAR HEATING

Reduce Mechanical Heating by Using Passive Solar Design

| WHO | KEY BENEFITS |
|---|---|
| ✓ Developer/PM Funder Policymaker | ✓ Health/IEQ Site/Community |
| ✓ Architect | ✓ Energy Efficiency Water Efficiency |
| ✓ Builder | ✓ Material Efficiency |
| ✓ Resident | ✓ O&M |
| ✓ Building Manager | ✓ Resident Satisfaction ✓ ENERGY STAR® |

Recommendation

Design for passive solar heating by:

- » Maximizing south-facing wall areas,
- » Controlling sunlight with shading devices, and
- » Regulating heat with thermal mass.

Description

Passive solar heating has been around since ancient times. The basic approach is to capture solar energy in thermal mass, which later reradiates the energy as heat. Balancing this delay so that it happens at night is achieved through building orientation, mass sizing, shading and insulation.

The first step in passive solar heating is to insulate the building to a very high level and to reduce infiltration so that stored heat won't be lost too quickly (*Planning & Design: Measure 11—Energy Star-Certified Homes / Systems: Measure 10—Advanced Ventilation Practices*).

The next step is to design a solar aperture that allows sunlight to enter the space during the winter, and cuts off sunlight during the hottest times in summer. This is achieved with proper building and window orientation and with shading.

Locating a rectangular building along its east-west axis will provide good solar orientation. Passive solar buildings should be aligned toward true south, which in the Bay Area is approximately 14 degrees west of magnetic south. The building does not have to be directly facing south, however. Even at 25 degrees off south, 90% of the total solar insolation (a measure of solar energy striking the earth) still falls on a wall. A south-facing orientation can also be beneficial for daylighting and natural ventilation (*Planning & Design: Measure*

03—Building Placement and Orientation / Systems: Measure 07—Avoid Air Conditioning / Systems: Measure 12—Daylighting).

The sun is at different levels in the sky at different times of the year. South-facing windows can receive sunlight throughout the day in winter, as shown below, while proper shading reduces the amount of heat entering the building in summer.

To create a comfortable interior, heat that enters through windows must be stored in thermal mass (*Systems: Measure 02—Thermal Mass Flooring*). Mass volume must be carefully balanced; too little mass can result in overheating, and too much may result in cold interiors in the winter if the mass material is never fully “charged” with sunlight during the day.

Benefits

Passive solar design can reduce heating and cooling requirements by 30% to 50% or more by keeping indoor temperatures within a relatively constant range throughout the year. Energy savings may justify smaller, simpler mechanical heating and cooling systems.

Application

Applicable to all multifamily housing, provided a building can be appropriately oriented on a site. Multistory developments face greater challenges with incorporating thermal mass, especially on floors above ground level.

Design Details



Many building designers lack experience with passive solar design because our society has come to rely on mechanical heating and cooling. *Consulting an expert solar designer is strongly recommended to ensure the building performs as desired.* Designers should be aware of the three main components of passive solar design: window area and placement, shading, and thermal mass.

WINDOW AREA AND PLACEMENT

Windows are critical for effective passive solar design. Proper south-facing window area will create a solar aperture that directs sunlight onto the building's mass materials. A rule of thumb for window-to-wall area ratio is 25% to 35%.

On the north-, west- and east-facing walls, minimize window area to the greatest extent possible while still accounting for daylighting and ventilation. Sunlight on east- and west-facing windows is difficult to control and can lead to overheating in summer. North windows rarely get direct sunlight and therefore create cold spots, but are excellent for daylighting. North windows should have low-conductivity frames with spectrally selective coatings (*Structure: Measure 13—High-Performance Windows / Systems: Measure 10—Advanced Ventilation Practices / Systems: Measure 12—Daylighting*).

EXTERIOR SHADING

Shading south-facing walls and windows requires careful design. Design for the time of year that walls or windows need to be fully shaded (cut-off). This depends on climate conditions and location; in general, the hottest days should coincide with full shading of south windows and walls. On the shortest days of winter, sunlight should be allowed to penetrate fully into the space. Check weather data for your site to determine dates for sunlight control. Overhangs, awnings, trellises and landscaping can provide shading.

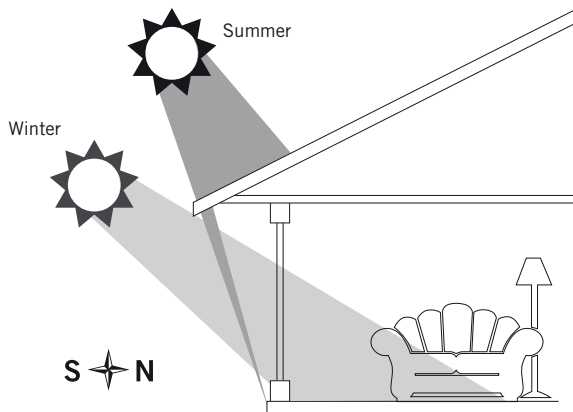

Proper overhang design on south windows will keep out the summer sun while allowing sunlight into the space on winter days.

THERMAL MASS

Sunlight entering a space passes through glass and strikes interior surfaces. Dark mass surfaces directly in contact with sunlight will absorb solar radiation more than light surfaces, and will slowly reradiate the energy as heat. Balancing the delay time is done by carefully sizing thermal mass within the building; consult an expert. Thermal mass can be incorporated in floors and other areas (*Systems: Measure 02—Thermal Mass Flooring*). Some ways to add mass are:

- » Tile or stained concrete floors
- » Two layers of 5/8-inch gypsum drywall
- » Masonry or tile fireplace surround

- » Concrete or tile countertops
- » Concrete mass walls or partial walls

Non-mass surfaces should be light colored to reflect heat back toward absorptive mass areas.

Code Considerations

California's Title 24 is limited in its ability to account for passive solar heating. Code requires that all buildings have some form of mechanical heating. A credit is available for thermal mass; consult a Title 24 expert for information.

Considerations for Residents

Teach occupants how passive solar heating works. Along with fixed overhangs, operable shading devices can aid passive solar heating. For example, shutters or blinds can be closed on hot summer days to fully shade mass floors.

Decorating can negate the effect of thermal mass; for example, a throw rug will reduce a mass floor's ability to store heat. To maximize reflectivity toward the floor, paint walls white or the lightest color acceptable to occupants.

Cost and Cost Effectiveness

| | | |
|----------------|--------|---|
| BENEFIT | ★★★ | Passive solar design increases design time and material costs in most cases. Extra concrete for mass in units adds cost, especially on suspended floor structures. Deep overhangs, awnings, trellises and other shading devices may add cost. |
| COST | \$\$\$ | |

However, passive solar design is probably the best way to reduce energy use in residential buildings and will provide savings throughout the building's life.

Resources

- » **U.S. Department of Energy (DOE)** and its Energy Efficiency and Renewable Energy (EERE) division have a good website with passive solar fundamentals: www.eere.energy.gov/RE/solar_passive.html
- » **Advanced Buildings Institute** has a good article on exterior shading devices: www.advancedbuildings.org/_frames/fr_t_lighting_ext_shading_devices.htm
- » **Builders Booksource**, Berkeley, CA, has books on passive solar design: www.buildersbooksource.com
- » **Energy 10** software for passive solar design: www.nrel.gov/buildings/energy10
- » **PG&E's Pacific Energy Center** provides climate data and numerous passive solar resources in their online library www.pge.com/pec (click on Resource Center and then E-Library)

THERMAL MASS FLOORING

Use Mass Flooring Together with Passive Solar Design

| WHO | KEY BENEFITS |
|---|--|
| <ul style="list-style-type: none"> ✓ Developer/PM ✓ Funder ✓ Policymaker ✓ Architect ✓ Builder ✓ Resident ✓ Building Manager | <ul style="list-style-type: none"> ✓ Health/IEQ ✓ Site/Community ✓ Energy Efficiency ✓ Water Efficiency ✓ Material Efficiency ✓ O&M ✓ Resident Satisfaction ✓ ENERGY STAR® |
| <p>09300: Tile Flooring</p> | |

Recommendation

Specify mass flooring to enhance passive solar design and provide a durable floor surface.

Description

Passive solar design has three main components: south-facing windows, shading, and a heat-trapping material (thermal mass). This measure covers thermal mass flooring (for a detailed discussion of passive solar design, see *Systems: Measure 01*).

Passive solar heating takes advantage of the sun shining through south-facing glass and striking interior materials such as floors, walls and furnishings. Nearly all this solar radiation is immediately converted to heat. Thermally massive materials—which work best when in direct contact with incoming sunlight—absorb and store this excess heat. The mass material then reradiates the stored heat as long-wave radiation with a delayed effect—and at a moderated temperature that is comfortable to occupants. This helps heat the home long after the sun has set.

Thermal mass can also absorb nighttime coolness and release it slowly during hot days, providing natural cooling.

TYPES OF MASS FLOORS

The type of flooring material has a large impact on the effectiveness of a passive solar design.



Dark colored tiles absorb and store the sun's heat in a passive solar house.

Mass floors rely on high densities to store heat. Tile on concrete and stained, colored or patterned concrete are good options. Both utilize the heat-trapping potential of concrete. Heavyweight concrete is preferable because it stores and conducts heat better than lightweight mixes. This may conflict with other measures, however, such as hydronic space heating where a lightweight concrete is used to minimize structural loads. But even a lightweight thin-slab will hold a significant amount of heat.



Covering slab floors with carpet, wood, linoleum or similar materials is counterproductive to passive solar heating. These materials actually insulate the concrete mass from the effects of solar gain.

Benefits

Passive solar design can offset heating needs during winter by 30% to 50%, and lessen cooling loads in summer.

Passive solar design can augment hydronic space heating, and reduce the heating system's operating time and costs (*Systems: Measure 04—Radiant Hydronic Space Heating*).

Thermal mass floors provide durable, easy-to-clean surfaces. Ceramic and porcelain tiles are made of natural materials that are relatively benign compared to some other flooring options. Some tile companies also manufacture tile from recycled materials (*Planning & Design: Measure 14—Recycled Products*). Stained concrete means that finish flooring isn't needed, which saves resources.

Application

For best results, use thermal mass floors in spaces directly adjacent to south-facing windows.

Design Details

Passive solar design has been understood and used since ancient times. Despite its long history, our recent reliance on HVAC systems to heat and cool our buildings has led to a loss of this knowledge among the general population, and even among building industry professionals. Consulting an experienced solar designer will help ensure the building stays comfortable and will perform as designed.

Integrated design. Thermal mass floors are an integral part of passive solar design. Consider the effects of passive heating and cooling on the overall design of the residences. With a good passive solar design, it may be possible to downsize mechanical heating and/or cooling equipment.

Floor color. Interior finish colors affect passive solar heat gain. Darker colors absorb more heat, and should be used on tile or concrete floors. Walls should have as light a color as possible to reflect sunlight and heat toward the mass floor. The following table lists common solar absorptance values of various building finishes:

| MATERIAL | ABSORPTANCE* |
|--------------------------|--------------|
| Flat black paint | 0.95 |
| Black concrete | 0.91 |
| Dark brown paint | 0.88 |
| Medium-light brown paint | 0.82 |
| Brown concrete | 0.85 |
| Spanish tile | 0.80 |
| Red brick | 0.70 |
| Uncolored concrete | 0.65 |
| Light green paint | 0.47 |
| White semigloss paint | 0.30 |

*For general purposes only. Actual products will vary because of texture, tone, pigments and other characteristics.

Code Considerations

Title 24 is limited in its ability to account for passive solar heating. Code requires that all buildings have some form of heating that meets minimum heating requirements. A credit is available for thermal mass; consult a Title 24 expert for more information.

Considerations for Residents

Occupants will need to be taught about the role of a thermal mass floor in a passive solar design. Decorating, for example, can negate the effect of thermal mass: a throw rug or area rug placed on a mass floor will reduce the floor's ability to store heat.

Walls should be painted the lightest color acceptable to occupants to maximize reflectivity toward the floor.

Cost and Cost Effectiveness

| | | |
|----------------|--------|---|
| BENEFIT | ★★★ | Tile floors range from \$3 to \$12 per square foot, installed. Staining or painting concrete will increase costs for concrete finishing, but there is no flooring material to install, often making costs similar to other floorcovering options. |
| COST | \$\$\$ | |

Resources

- » **Builders Booksource**, Berkeley, CA, has books on passive solar design: www.buildersbooksource.com
- » **Energy 10**, software for passive solar design: www.nrel.gov/buildings/energy10
- » **U.S. Department of Energy (DOE)** and its Energy Efficiency and Renewable Energy (EERE) division have a good website with passive solar fundamentals: www.eere.energy.gov/RE/solar_passive.html
- » **PG&E's Pacific Energy Center** provides climate data and numerous passive solar resources in their online library: www.pge.com/pec (click on Resource Center and then E-Library)
- » **ACWMA's Materials Database** lists products that correspond with this measure: www.multifamilygreen.org

HIGH-EFFICIENCY HEATING

Save Energy with High-Efficiency Heating Equipment

| WHO | KEY BENEFITS |
|---|--|
| <ul style="list-style-type: none"> ✓ Developer/PM ✓ Funder ✓ Policymaker ✓ Architect ✓ Builder Resident Building Manager | <ul style="list-style-type: none"> ✓ Health/IEQ Site/Community ✓ Energy Efficiency Water Efficiency Material Efficiency ✓ O&M ✓ Resident Satisfaction ✓ ENERGY STAR® |
| <p>DIVISION 15: Mechanical</p> | |

To keep construction costs low, many affordable housing projects utilize low-cost, wall-mounted or baseboard electric heaters, or wall furnaces. But electric heating is far less efficient than gas heating, and using electric baseboard heating can make it difficult to meet Title 24 requirements. And a central unit-sized furnace with a setback thermostat is generally more efficient than multiple wall or baseboard heaters with individual controls. A setback thermostat on a central heating system allows residents to turn down the heat in the entire apartment without having to go from room to room adjusting settings on individual units.

Furnaces must, by law, have a minimum Annual Fuel Utilization Efficiency (AFUE) of 78%. The minimum requirement for gas-fueled boilers is a bit lower at 75%. Furnaces that meet ENERGY STAR® requirements are at least 90% efficient. Furnaces with efficiency greater than 90% AFUE are of the condensing type and may require special condensate acid neutralization in the drain. ENERGY STAR®-labeled boilers must be 85% efficient or higher.

The improvements in efficiency in both boilers and furnaces have been achieved through improvements in components, such as a secondary heat exchanger, electric ignition, and direct or power venting.

Recommendation

Specify natural gas-fueled heating equipment that meets the ENERGY STAR® criteria or has an AFUE of at least 90% for furnaces and 85% for boilers.

Description

Multifamily buildings have either:

- » Independent, unit-sized furnaces in each dwelling;
- » Centralized, multi-unit hydronic heating;
- » Independent hydronic heating; or
- » Independent electric baseboard or wall heaters.

Compared to heating with electricity, gas heating is more economical and environmentally preferable. Electricity is produced in large generation plants, and then transported through power lines. By the time electricity is used in a home, it is less than 40% efficient due to generation, transmission and other losses along the way. Natural gas, on the other hand, is piped directly to the place of use where it is combusted.

Benefits

High-efficiency equipment saves money through reduced fuel use. Also, by using less fuel, high-efficiency heating equipment emits fewer pollutants into the air compared to standard equipment.

Furnaces with an AFUE greater than 88% are often power- or direct-vented, or have sealed combustion. In sealed-combustion systems with direct venting, exhaust is piped to the outside, and combustion air is drawn from the outside instead of from indoors. This reduces the risk of backdrafting carbon monoxide, which is potentially harmful to occupants.

Sealed combustion with direct venting also allows installation to be done through sidewalls with piping, which reduces the installation difficulties of traveling vertically through multiple floors and the roof.

Application

Applicable to all multifamily buildings.

Design Details

If a building is designed with energy-efficient features such as increased insulation, air sealing, high-performance windows and high-efficiency duct systems, it may be possible to install smaller, more efficient heating systems (*Planning & Design: Measure 11—ENERGY STAR® Certified Homes*).

Code Considerations

California's Title 24 currently allows electric heat in multifamily housing without significant penalties. Often, a building with an efficient central domestic hot water (DHW) boiler can achieve enough energy savings to offset the Title 24 penalty for electric heat. However, starting with the 2005 changes to Title 24, heating system requirements will be much more stringent for multifamily buildings, and will essentially require gas heating. Adopting centralized heating (either in-unit or buildingwide) will help prepare for future changes to code and save operating costs now.

Considerations for Residents

High-efficiency heating has some distinct advantages for occupants over small unit heaters. First, occupants feel more comfortable because the home is evenly heated, eliminating cold spots. Second, furnaces pose less of a fire hazard than electric wall units do.

Programmable thermostats conserve energy by allowing for setback when residents are away during the day or asleep at night.



Choose programmable thermostats that meet ENERGY STAR® criteria.

Central furnaces can be specified that have sealed combustion or direct venting to reduce the possibility of backdrafting of combustion gasses, a potential health problem.

Finally, high-efficiency gas furnaces cost considerably less to operate than electric or gas wall heaters.

Cost and Cost Effectiveness

| | | |
|----------------|--------|--|
| BENEFIT | ★★★ | Electric or gas wall heaters are very inexpensive, making high-efficiency heating considerably more expensive upfront. However, the added cost of larger electrical subpanels or transformers to accommodate electric heat can lead to skyrocketing costs. |
| COST | \$\$\$ | |

In addition, 90% AFUE unit-size furnaces are currently about 30% to 40% more expensive than minimally compliant 78% AFUE units. Paybacks are in the six- to seven-year range.

Condensing furnaces cost considerably more than the standard efficiency furnaces—often as much as 50% to 80% more. High-efficiency boilers last a long time, but come in a limited range of sizes at a reasonable cost. Expect to pay a 50% to 100% premium for a condensing boiler over a minimally compliant boiler.

Resources

- » **EREN/DOE's** website discusses the benefits of higher efficiency furnaces and boilers, and provides links to manufacturers:
www.eere.energy.gov/buildings/multifamily
- » **ACEEE** lists the top-performing gas-powered furnaces:
www.aceee.org/consumerguide/topfurn.htm
- » **ENERGY STAR®**-qualified models are listed at:
www.energystar.gov and
www.buildinggreen.com

RADIANT HYDRONIC SPACE HEATING

Use In-Slab and Baseboard Radiant Hydronic Systems for Comfortable, Efficient Heating

| WHO | KEY BENEFITS |
|---|--|
| <ul style="list-style-type: none"> ✓ Developer/PM ✓ Funder Policymaker ✓ Architect ✓ Builder Resident Building Manager | <ul style="list-style-type: none"> ✓ Health/IEQ Site/Community ✓ Energy Efficiency Water Efficiency Material Efficiency ✓ O&M ✓ Resident Satisfaction ✓ ENERGY STAR® |
| DIVISION 15: Mechanical | |

Recommendation

Combine domestic water heating with a high-efficiency radiant hydronic system for space heating.

Description

Radiant hydronic floor heating has been popular in the United States for more than 50 years. Radiant heating systems radiate heat from a hot surface instead of blowing warm air from a furnace.

The two types of radiant hydronic systems—in-slab and baseboard—operate at different water temperatures, but can be used in combination or separately with a single boiler. Good energy efficiency is achievable because with radiant heating, people feel comfortable at setpoints 5 to 10°F lower than with forced air. This is partly a result of heating people's feet the most and heads the least—an optimal heating pattern for comfort. And it is partly a result of eliminating drafts in heating mode, which tend to cool people down.

In-slab systems. Early in-slab systems used copper pipes embedded in concrete floors. Modern systems use flexible cross-linked polyethylene (PEX) piping and have sophisticated controls that turn on and off to maintain a setpoint with a minimum of energy. Leaks are also much less likely to appear in modern systems, and if they do occur, they are easier to repair than in earlier systems.

Baseboard systems. These pump hot water through radiators located in different areas or zones throughout the apartment. Baseboard systems have not changed much in the last 50 years, although now they too are plumbed with PEX tubing and have better controls.

Benefits

Radiant heat feels good because it heats objects, not air. In a tight house, radiation warms the occupants and the surfaces surrounding them. Comfort is achieved at a lower temperature setpoint than with forced-air heating, saving energy. In-floor radiant heating also has an aesthetic advantage because grilles and registers aren't needed.

In buildings that don't need central air conditioning, a large advantage of radiant hydronic heating systems is elimination of all ducts and fan units. The related components (pipes and pumps) take up no interior space, making architectural design simpler and potentially reducing deck-to-deck height needs. Combined hot water/space-heating systems have the greatest potential for economic savings, especially when high-efficiency and long-life equipment are selected.

Application

Radiant hydronic heating with a central heat source is most appropriate for buildings with a shared gas meter on this end use. If energy use must be entirely separately metered, then individual water heater/fan-coil units should be used instead of in-slab or baseboard systems.

Design Details

COMMON INSTALLATIONS FOR HYDRONIC HEAT

- » **Slab-on-grade.** PEX tubing is tied to the rebar inside the foundation slab. Slabs-on-grade should have 2 in. or more of extruded polystyrene perimeter insulation to control heat loss to the ground.
- » **Thin-slab.** PEX tubing is stapled to the subfloor before the thin slab is poured on top. This is generally used on above-grade floors with gyprocrete.
- » **Baseboard.** PEX tubing is plumbed through walls, ceilings or floors to reach the baseboard radiators.

ZONING AND CONTROLLERS

Although complex zoning is easily accomplished with radiant hydronic systems, it is rarely needed in multifamily housing. Generally, one or at most two zones per unit are adequate.

New controllers are available that have smart chips in them that "learn" occupant heating patterns to optimize efficiency. New controllers can also account for thermal lag, which is the time it takes a slab floor to heat up and reach a room's desired temperature. This lag time can be lengthy, so an intelligent controller can effectively "wake-up" a home to the correct temperature, or shut down so that the rooms are not overheated during sleeping hours.

HOT WATER SYSTEMS

In-slab systems use water heated to 120°F or less while baseboard systems use 80 to 140°F water. Water is provided at these temperatures by central boilers or instantaneous water heaters. The relatively low water temperatures needed for in-slab heating makes it a good match for solar hot water systems (*Systems: Measure 05—Solar Water Heating*). Some hydronic systems use hot water from small residential water heaters to heat fan coils in a forced-air system. These have the advantage of being completely unitized and the disadvantage of being less energy efficient than central boilers.

Boilers used to feed radiant hydronic systems can be very small—generally less than one-half the size of the water heaters they replace. For combined space and water heating systems, select a high recovery rate on the heating unit.

TUBING

In-slab systems embed piping inside the concrete with wire to minimize cracking. Some installers still use copper or metal tubing, but in some cases the metal can react with the concrete, causing failure. Use PEX tubing to eliminate this problem. PEX has fewer joints and is strong, flexible and cheaper to install than metal tubing. Space PEX tubes between 6 and 12 in. apart. With wood floors, space the tubes at the lower end of this range to allow for even expansion and contraction.



Radiant heating PEX tubing is installed prior to lightweight concrete being poured in this suspended floor application.

MULTISTORY BUILDINGS

For multistory installations, baseboard heaters in upper floors can save money because structural requirements will be reduced compared to a thin-slab floor. Another option is to use engineered wood products that have a radiant barrier face with tubing embedded in it (one such product is called Thermalboard). Flooring is installed over this substrate.

COMMISSIONING

It is very important to commission the system thoroughly—from planning and design through occupancy.

Code Considerations

Systems are available that meet all local codes and regulations. Tubing can be either metal or an approved plastic, such as PEX.

A supplemental ventilation system must be used to meet minimum air change requirements if no forced-air equipment is installed (*Systems: Measure 07—Avoid Air Conditioning / Systems: Measure 10—Advanced Ventilation Practices*). Natural ventilation plus kitchen and bath exhaust fans will meet this intent in most cases.

Considerations for Residents

Radiant heating is better for indoor air quality than forced-air heating. People with allergies often prefer radiant systems because they do not stir up dust, pollen, pet dander and other indoor air contaminants. Also, radiant heat is quiet and provides uniform heating.

People new to radiant heating are often initially uncomfortably warm because they set the thermostat at 70 to 72°F. Energy savings are possible when occupants are educated about setting their thermostats at 60 to 65°F.

Cost and Cost Effectiveness

| | | |
|----------------|----------|---|
| BENEFIT | ★★★ | High-efficiency hydronic heating systems cost less to operate than gas-fired furnaces, and much less than electric heat. Adding solar water heating can further reduce operating costs. First costs are higher than furnaces, however, and therefore are most cost effective when combining space and domestic water heating systems to eliminate a mechanical air distribution system. |
| COST | \$ \$ \$ | |

In-slab systems can cost from \$5 to \$15 per square foot to install, depending on complexity. Baseboard heaters range from \$15 to \$25 per linear foot installed. PEX tubing costs about \$0.50 per foot.

Boilers used to supply hot water are a good investment because they provide long-term cost savings. They add considerable first cost over storage tank water heaters, but have long warranties. Some boilers last 50 years or more.

Resources

- » *Environmental Building News* article: Radiant-Floor Heating: When it Does – and Doesn't – Make Sense, Volume 11, No. 1, www.buildinggreen.com
- » **U.S. Department of Energy, Energy Efficiency and Renewable Energy**, has an online article (and excellent bibliography) on radiant floor heating and cooling systems: www.eere.energy.gov/consumerinfo/factsheets/bc2.html
- » **ACWMA's** Materials Database lists products that correspond with this measure: www.multifamilygreen.org

SOLAR WATER HEATING

Use Solar Collectors to Preheat Domestic Hot Water

| WHO | KEY BENEFITS |
|---|--|
| <ul style="list-style-type: none"> ✓ Developer/PM ✓ Funder ✓ Policymaker ✓ Architect ✓ Builder Resident ✓ Building Manager | <ul style="list-style-type: none"> Health/IEQ Site/Community ✓ Energy Efficiency Water Efficiency ✓ Material Efficiency ✓ O&M ✓ Resident Satisfaction ✓ ENERGY STAR® |
| <p>13600: Solar Collectors, Components and Equipment</p> | |

- » **Flat plate collector.** Water or another liquid is circulated through a glass-covered, sealed box where the fluid is heated by the sun. The resulting water is stored in a tank usually located in the building. Efficiency: Up to 40%.
- » **Evacuated-tube collector.** These collectors are constructed so that the fluid heating happens inside a vacuum, thus increasing efficiency. Storage is in a tank inside the building. Efficiency: Up to 60%.

Collector systems can be configured in a number of ways, depending on site-specific needs. Most systems (except for batch collectors) require storage tanks; these tanks hold water that has been heated in the collector by the sun and deliver it to the residences. Storage tanks can also have heating elements in them for back-up when the collectors are not providing hot water. Boilers and instantaneous water heaters connected to the system can serve as a back-up so that hot water is always available.

Recommendation

Use solar collectors for preheating a central boiler or install a solar water heating system for each dwelling unit.

Description

Solar water heating systems are available in many configurations. Most systems for multifamily housing circulate water to the solar collectors with a small pump and store the solar-heated water in a tank next to the boiler or gas water heater. The systems use the sun to heat the water partway to the setpoint, and use a boiler or gas water heater to complete the heating process (*Systems: Measure 06—High-Efficiency Water Heating*).

Medium-temperature systems that raise water to between 110°F and 180°F are the most common for domestic hot water (DHW) applications. There are a number of solar hot water collector systems. The three most common are described below:

- » **Integral collector storage (ICS),** or “batch.” These systems are passive—they do not require any pumps or motors to circulate the hot water. The water is stored where it is heated (on the roof in most cases). Efficiency: Up to 30%.

Benefits

Solar hot water systems can pay back in as little as seven years and reduce the use of gas or electricity for water heating by up to 70%.

Application

Applicable to most multifamily new construction and remodel projects. If solar water heating is not financially feasible, consider pre-plumbing for solar hot water to reduce future installation costs. This entails providing south-facing roof space for panels and appropriate plumbing configurations to a mechanical room.

If the design team is considering hydronic space heating, solar water heating can be an effective preheater (*Systems: Measure 04—Radiant Hydronic Space Heating*).



Solar panels can double as covered parking.

Design Details



Consult a solar hot-water designer who is knowledgeable about multifamily construction early in the design process to help the architect plan for appropriate roof loads and adequate space on the roof and in the mechanical room.

The best performance occurs when panels face due-south with a pitch of 40 degrees and no shadows. However, if placed within 45 degrees of south at a moderate pitch, the system can still operate at efficiencies up to 90% of the ideal position.

Code Considerations

In 2005, Title 24's water heating requirements for multifamily housing will become stricter. Currently, all units in a multifamily building are assumed to have the equivalent of one 50-gallon storage tank. However, with centralized boilers becoming prevalent in the multifamily market, many developers are getting substantial energy credits by using a combined system that feeds several units. Title 24 will be modified in 2005 to include a more realistic assumption of water use. This will make compliance more difficult than in the past. Solar water heaters can significantly reduce fuel needed to heat water, and therefore help with energy code compliance.

Solar water heating has been in use for over 30 years. Most code officials and jurisdictions are aware of solar water heating and should not raise any difficulties with issuing permits.

Considerations for Residents

No adverse effects for residents. Residents will receive hot water at the same temperatures as without solar, even if the sun is not shining, assuming there is a backup water heater.

Cost and Cost Effectiveness

| | | |
|---------|--------|--|
| BENEFIT | ★★★ | A typical multifamily solar hot water system will cost between \$1000 and \$3000 per unit, depending on the system's size. Paybacks are in the three to eight year range. Rebates are sometimes available for solar water heating systems; check with installers for more information. |
| COST | \$\$\$ | |

Large central boilers can be preheated by solar collectors and cost less than individual water heaters in each unit.

It is possible to have one central boiler that serves as space heating and DHW purposes. The combined savings of eliminating furnaces and reduced energy use can offset the cost of installing solar water heating.

Resources

- » **Northern California Solar Energy Association** has information on solar hot water systems and list of contractors and suppliers:
www.noricalsolar.org
- » **Building Green**, publisher of *Environmental Building News*, has a good article on solar water heating (Vol. 8, No. 7/8). Their website has information on system components:
www.buildinggreen.com
- » **California Energy Commission** has information on solar hot water systems including rebate programs:
www.consumerenergycenter.org
- » **ACWMA's Materials Database** lists products that correspond with this measure:
www.multifamilygreen.org

HIGH-EFFICIENCY WATER HEATING

Specify High-Efficiency Gas Water Heaters or Boilers

| WHO | KEY BENEFITS |
|---|--|
| <ul style="list-style-type: none"> ✓ Developer/PM ✓ Funder Policymaker ✓ Architect ✓ Builder Resident ✓ Building Manager | <ul style="list-style-type: none"> ✓ Health/IEQ Site/Community ✓ Energy Efficiency ✓ Water Efficiency Material Efficiency ✓ O&M ✓ Resident Satisfaction ✓ ENERGY STAR® |
| 15480: Domestic Water Heating | |

Recommendation

Specify storage gas water heaters with an energy factor (EF) of at least 62%.

If a boiler is used instead, ensure it has an Annual Fuel Utilization Efficiency (AFUE) of at least 85%.

When possible, supplement water heating needs with solar heating systems *(Systems:*

Measure 05—Solar Water Heating).

Description

Water heating accounts for a significant portion of energy use in multifamily housing. That cost can be reduced by installing high-efficiency domestic hot water (DHW) appliances such as storage water heaters and gas-fired boilers. The type of heating equipment used depends on how much hot water is needed and how it will be metered on the site.

For centralized DHW systems, it is usually more expensive to purchase a high-efficiency boiler than to use multiple high-efficiency water heaters. However, a boiler often is the least expensive option over time wherever water use is large. When choosing between the two options, keep in mind that boilers can last 40 to 50 years while water heaters typically last less than 15 years.

If each unit has its own water heating, then use one of the widely available high-efficiency gas storage heaters with an energy factor of at least 0.62. For individual units, it is usually cost-prohibitive to purchase condensing heaters with energy factors as high as 0.82, but this can be considered for projects that have sufficient budget.

Another option is to supply or supplement water heating needs with tankless water heaters. Tankless or “instantaneous” water heaters are generally more efficient than standard tank systems since they only heat water when it is needed; there is no tank of hot water slowly losing heat 24 hours a day. Tankless systems with electric ignition use even less fuel than systems with a pilot light.

For all water heating systems, the use of solar collectors can further reduce energy use and take advantage of free energy. Solar systems can augment or preheat water for boilers and storage-tank type heaters.

Benefits

High-efficiency water heating equipment saves money by reducing energy use and improving equipment performance.

Most high-efficiency boilers and storage tank water heaters also have the benefit of direct venting with sealed combustion. Sealed combustion in gas-fueled appliances reduces the risk of backdrafting combustion gasses into the home. Boilers placed in mechanical rooms also benefit from direct venting because often draft hoods or dampers can be eliminated.

Efficient hot water systems will help in achieving an ENERGY STAR® rating on homes *(Planning & Design: Measure 11).*

Application

High-efficiency central hot water systems make sense in multifamily applications where water use is large. Individual storage tank water heaters can be used where independent hot water systems are desired. Tankless heaters are applicable in a number of applications, including remote locations like a bathroom or sink located away from the rest of the DHW system. They can also be installed for entire residences to replace storage tank heaters.

In very energy-efficient buildings, tankless heaters can be combined with other equipment to provide hot water for space heating and domestic use *(for more on combined systems, see Systems: Measure 04—Radiant Hydronic Space Heating).*

Design Details

High-efficiency equipment may require somewhat different installation than standard efficiency units. Some systems, for example, may need a condensate neutralization drain. Central systems that provide hot water to multiple units will require adequate space in equipment rooms.

Solar hot water systems can further increase efficiency by acting as a preheater. *If the cost of installing a solar hot water system is prohibitive today, consider pre-plumbing for a future solar installation.* During construction it is relatively inexpensive to pre-plumb for a solar hot water system, whereas installing the plumbing later is costly (*Systems: Measure 05—Solar Water Heating*).

With an investment in design and first costs, a combined DHW and space heating system can be designed that provides both hydronic radiant heat and potable hot water. Some cost reductions elsewhere in a project can occur from combining systems, such as eliminating ductwork and furnaces, thus helping reduce costs.



A high-efficiency boiler and storage tank provide hot water for residents and feed a radiant hydronic heating system (white tubing at left).

Code Considerations

Select units that are certified by the California Energy Commission for use in California. These are readily available from suppliers.

In 2005, California's Title 24 energy code requirements will become stricter for water heating in multifamily housing. Currently, all units in a multifamily building are assumed to have the equivalent of one 50-gallon storage tank. However, with centralized boilers becoming prevalent in the multifamily market, many developers are getting substantial energy credits by using a combined system that feeds several units. The energy code will be modified in 2005 to include a more realistic assumption of water use. This will make compliance more difficult than in the past. High-efficiency water heating strategies will soon be mandatory, so early adoption will help meet the 2005 code requirements.

Considerations for Residents

Residents and owners will benefit from reduced costs for water heating.

Where high-efficiency gas water heaters are specified, sealed combustion ensures that carbon monoxide and other pollutants are exhausted to the outside, which helps protect indoor air quality.

Cost and Cost Effectiveness

| | | |
|----------------|--------|--|
| BENEFIT | ★★★ | Higher efficiencies on DHW equipment are obtained through better parts and components, which result in longer-lasting products. For this reason, high-efficiency equipment costs more—sometimes significantly more—than the lowest efficiency equipment. The increased cost is recovered through savings in maintenance and longer product life. |
| COST | \$\$\$ | |

Resources

- » **U.S. Department of Energy's Office of Energy Efficiency and Renewable Energy (EERE)** website provides information about higher efficiency equipment and links to manufacturers: www.eere.energy.gov/buildings
- » **ACWMA's Materials Database** lists products that correspond with this measure: www.multifamilygreen.org

AVOID AIR CONDITIONING

Design Buildings So That Air Conditioning Can Be Eliminated

| WHO | KEY BENEFITS |
|--------------------|-------------------------|
| ✓ Developer/PM | ✓ Health/IEQ |
| ✓ Funder | Site/Community |
| ✓ Policymaker | ✓ Energy Efficiency |
| ✓ Architect | Water Efficiency |
| ✓ Builder | Material Efficiency |
| ✓ Resident | ✓ O&M |
| ✓ Building Manager | ✓ Resident Satisfaction |
| | ✓ ENERGY STAR® |

Recommendation

Design the building with improved insulation, shading, thermal mass and ventilation so that air conditioning can be eliminated.

Description

Properly designed buildings can be comfortable with little or no air conditioning even in the hottest areas of Alameda County. With a good passive solar design (*Systems: Measure 01*) homes can be kept below 80°F even during the worst heat waves. The first step is to use insulation and shading to reduce the amount of heat entering the building. Second, use thermal mass materials to create a heat sink. Finally, use ceiling fans—and potentially whole-house fans—to keep residents cool and flush warm air out of the units at night.

Insulation. To minimize heat entering a building in the summer, insulate the walls, floors and ceilings above code minimums. Here are recommended insulation levels:

- » Walls: R-19 to R-22
- » Ceilings: R-38 to R-49
- » Floors over garages and other unconditioned spaces: R-19 to R-25

For areas that exceed 90°F for at least one month every summer (or 30 days in a year), use radiant barrier sheathing on the underside of any sloped roofs. For flat roofs in these hot zones, use a cool roof (*Structure: Measure 12* / *For more on energy-efficient home construction, see Planning & Design: Measure 11—ENERGY STAR®-Certified Homes.*)

Shading. To further reduce solar heat loads, design overhangs, awnings, sidefins, landscaping, and other shading devices (*Systems: Measure 01—Passive Solar Heating*).

Thermal mass helps cool a building by acting as a heat sink. Cool evening air from the outdoors enters the building either by opening windows or running a whole-house fan. The cool air is absorbed by thermally massive materials such as concrete and tile flooring and gypsum board. During the day, these mass materials release their coolness, reducing interior temperatures (*Systems: Measure 02—Thermal Mass Flooring*).

Ventilation. In a building with no air conditioning, ventilation can be provided mechanically, naturally, or through both means. A central ventilation system can help flush out hot air in the summer (*Systems: Measure 10—Advanced Ventilation Practices*). Other effective strategies include ceiling fans and whole-house fans used in conjunction with natural ventilation, which takes advantage of prevailing winds to draw air into the home (*for more about natural ventilation, see Design Details*).

Benefits

Benefits of avoiding air conditioning include:

- » Moderate to significant capital cost savings, depending on whether the system is downsized or eliminated
- » Significant energy cost savings
- » Improved air quality from greater ventilation rates
- » Significantly improved acoustics from better insulation and from reduced system noise (except during the brief use of the whole-house fan, which is as noisy as a forced-air system)

Application

Applicable throughout the Bay Area. This measure may not be appropriate for residents who need a constant temperature.

In some locations, especially in rural areas near active farming, residents experience problems with natural ventilation due to dust and allergens. Air filtration may be necessary in these areas (*for options on reducing its environmental effects, if air conditioning cannot be eliminated, see Systems: Measure 08—High-Efficiency Air Conditioning with Advanced Refrigerant*).

Design Details

Eliminating air conditioning is a performance goal that must be planned for very early in the design process. Like daylighting and passive solar design, this measure depends heavily on early decisions regarding orientation, building massing, glazing location and area, wall and roofing thickness, and insulation.

DESIGN TIPS FOR NATURAL VENTILATION

- » Situating the longer walls of the development toward the prevailing winds helps with cross ventilation.
- » When wind strikes a wall, an air pressure difference is created across the building. To balance the pressure difference, place equal areas of operable windows on the building's windward and leeward sides. When these windows are open during windy periods, a suction effect pulls pressurized air through the space.
- » In buildings of at least three stories, combine cross ventilation with stack ventilation. Stack ventilation takes advantage of differences in air densities. Place windows low for incoming air, and high for exiting air. Hotter air will rise and exit through apertures higher in the space, thereby sucking in air from the lower windows. A good design for stack ventilation is to place exhaust windows at the top of stairwells on multistory units.
- » Ceiling fans can help induce cross and stack ventilation when the outside air is still. Air movement from the fans also helps occupants feel cooler.

Code Considerations

Some funders require air conditioning under certain circumstances. In these cases, it is usually possible to downsize the system by more than half and still meet their requirements.

Title 24 assumes that some form of cooling is provided in residential buildings. Natural ventilation in lieu of air conditioning can be complex to account for in energy modeling. Use a Title 24 expert to help calculate the code effects of natural ventilation.

Considerations for Residents

Residents benefit from lower utility bills, better air quality from higher ventilation rates, and better acoustics from increased insulation and mass.

Teach residents how to best keep their homes cool. For example, to many people it is counterintuitive to close windows when it is hot outside, but with a passive solar design, keeping the windows closed helps the mass materials retain nighttime coolness well into the day.

In residents' manuals, clearly illustrate how to operate units to reduce air conditioning needs (*Operations & Maintenance: Measure 01—Training and Manuals*).

Cost and Cost Effectiveness

| | | |
|----------------|---------|---|
| BENEFIT | ★★★ | Eliminating or downsizing air conditioning systems will more than pay for most window and overhang upgrades. Awnings and overhangs can be simple or complex, and thus range greatly in price. |
| COST | \$ \$\$ | |

Ceiling fans cost between \$200 and \$400 each, installed. For best results, specify fans with fluorescent bulbs and high-efficiency motors that are quiet and have at least two speeds. Many models of ENERGY STAR® ceiling fans are available.

Resources

- » **Collaborative for High Performance Schools (CHPS)**
Best Practices Manual, Vol. 2 discusses natural ventilation: www.chps.net.
- » **American Society of Heating, Refrigerating and Air-Conditioning Engineers (ASHRAE)**
ASHRAE Standard 62-1999, Ventilation for Acceptable Indoor Air Quality: www.ashrae.org

HIGH-EFFICIENCY AIR CONDITIONER WITH ADVANCED REFRIGERANT

Specify High-Efficiency A/C with Environmentally Preferable Refrigerant

| WHO | KEY BENEFITS |
|--|--|
| <ul style="list-style-type: none"> ✓ Developer/PM Funder Policymaker | <ul style="list-style-type: none"> Health/IEQ Site/Community |
| <ul style="list-style-type: none"> ✓ Architect Builder Resident Building Manager | <ul style="list-style-type: none"> ✓ Energy Efficiency Water Efficiency ✓ Material Efficiency ✓ O&M ✓ Resident Satisfaction ✓ ENERGY STAR® |
| <p>15700: Air Conditioning Equipment</p> | |

Recommendation

Install 13 SEER and 11 EER or higher air conditioning with a thermostatic expansion valve (TXV).

Stay a step ahead of refrigerant phaseouts by specifying advanced refrigerants that reduce impacts on ozone depletion and global warming.

Description

Compressor-based air conditioning has two important environmental impacts:

- » Energy consumption
- » Potential ozone depletion from leaking refrigerants

ENERGY CONSUMPTION

Seasonal Energy Efficiency Ratio (SEER) is a rating of cooling system efficiency at low temperatures, while Energy Efficiency Ratio (EER) is a high temperature performance rating. The higher the SEER/EER, the less energy is used to provide comfort. A high SEER/EER ensures that the air conditioner operates at high efficiency during the full range of summer temperatures.

A TXV is a refrigerant regulation device that helps the air conditioner operate at maximum efficiency over a wide range of conditions.

REFRIGERANTS

Older refrigerators and air conditioners used chlorofluorocarbon (CFC) refrigerants. CFCs damage the stratospheric ozone layer and contribute to global warming. In compliance with the Montreal Protocol, the United States ended CFC production in 1995. Since then, CFC leaks to the atmosphere have significantly declined.

Today there are numerous CFC substitutes on the market. Some are better than others in terms of ozone-depleting potential (ODP) and global warming potential (GWP) ratings, but there are no perfect refrigerants. Eliminating mechanical cooling is the only certain way to reduce ODP and GWP from building cooling (*Systems: Measure 07—Avoid Air Conditioning*).

R-22 is a hydrochlorofluorocarbon (HCFC) refrigerant used in residential cooling systems. While much less destructive to the ozone layer than CFCs, HCFCs do contain chlorine, an ozone-destroying chemical. Also, the manufacture of R-22 creates a by-product that contributes to global warming. Starting in 2010, under the Clean Air Act, manufacturers will no longer be allowed to produce new air conditioners using R-22.

Some new products on the market use an advanced refrigerant called R-410a (known under the trade names Puron, Genetron AZ-20, or Suva 410a). These are a blend of hydrofluorocarbons (HFCs) that do not contribute to ozone depletion, but do have some GWP, though less than R-22. No refrigerant is perfect.

Benefits

Energy-efficient air conditioners cost less to operate. High-efficiency units are usually top-of-the-line products with better motors and components than standard equipment, and should therefore last longer. Right-sized air conditioners provide greater comfort, are less noisy, and last longer than oversized units. Installing an air conditioner with a TXV lowers utility bills and saves energy through improved performance.

Using an environmentally preferable refrigerant will reduce the effect buildings have on ozone depletion and global warming.

Application

Central residential air conditioners are available that are highly efficient and use an environmentally preferable refrigerant.

Through-the-wall, mini-split systems, and package terminal units often do not use R-410a advanced refrigerants. Look for ENERGY STAR® labels on these smaller units to ensure high efficiency.

Design Details

Higher SEER (13 to 18 SEER) and higher EER (11 or greater) units are installed like any other air-conditioning equipment. Some air conditioners come with a factory-installed TXV; others accept a TXV that can be bolted on.

SYSTEM SIZING

Many of the advantages of high-efficiency air conditioners will be lost if the system is oversized, a common problem in residential buildings. From a builder's standpoint, installing larger, more powerful equipment ensures that even leaky, poorly designed ductwork will deliver enough cold air to the home.

But if a home is insulated above code, has high-performance windows, and has other features of an ENERGY STAR® home (*Planning & Design: Measure 11*), a smaller, right-sized air conditioner can provide better comfort and performance. A smaller unit runs longer than an oversized system, at a much higher efficiency, and provides more uniform and consistent performance. Oversized units are loud, create cold zones in front of registers, and stress the equipment more than a properly sized unit.

Careful ductwork sealing, insulation, sizing and placement significantly increases the efficiency of cooled air delivery (*Systems: Measure 09—Duct Effectiveness*).

HANDLING REFRIGERANTS

Take care with refrigerant handling. Always select a reputable dealer employing service technicians who are EPA-certified to handle refrigerants.

Code Considerations



Air conditioners are notorious for not reaching published efficiencies out-of-the-box. New air conditioners must be tested and balanced properly to ensure good working order.

Using advanced refrigerants like R-410a is one way to stay a step ahead of the R-22 phaseout in 2010. This makes maintenance less of a burden (and cost) later in the equipment's life.

Considerations for Residents

Correctly sized high-efficiency air conditioners reduce energy costs, improve comfort and produce less noise. Environmentally preferable refrigerants have no direct effect on occupants.

Cost and Cost Effectiveness

| | | |
|---------|--------|--|
| BENEFIT | ★★★ | High-efficiency central air conditioners cost more than standard units. |
| COST | \$\$\$ | The cost typically goes toward better components, including sound dampening technologies, better compressors, and multispeed premium motors. Paybacks can be short in hotter climates where air-conditioning loads are substantial. Most manufacturers reserve the advanced refrigerants for their higher efficiency models. |

Properly sizing an air-conditioning system may allow installation of a smaller unit, which costs less to buy and to operate. Extra design time is needed, however, to correctly model and design the cooling system to accurately match the load.

PG&E offers rebates—currently up to \$425—for high-efficiency air conditioners. This incentive usually covers the cost of upgrading to a higher efficiency, and can also help offset design costs.

Resources

- » **U.S. Environmental Protection Agency** has information on ozone depletion from refrigerants, including alternatives to CFCs and information on phaseout regulations: www.epa.gov/ozone/snap
- » **Consortium for Energy Efficiency** has information on energy-efficient air conditioners for multifamily buildings: www.cee1.org
- » **ACWMA's Materials Database** lists products that correspond with this measure: www.multifamilygreen.org

DUCT EFFECTIVENESS

Properly Size, Seal and Insulate Ducts for Better Performance

| WHO | KEY BENEFITS |
|--|--|
| <ul style="list-style-type: none"> ✓ Developer/PM Funder Policymaker ✓ Architect ✓ Builder Resident Building Manager | <ul style="list-style-type: none"> ✓ Health/IEQ Site/Community ✓ Energy Efficiency Water Efficiency Material Efficiency ✓ O&M ✓ Resident Satisfaction ✓ ENERGY STAR® |
| 15800: Ducts | |

Recommendation

Ensure that forced-air HVAC ducts operate properly and efficiently by insulating and sealing them.

Size and lay out the distribution systems appropriately and locate ducts within conditioned areas of the building envelope where possible.

Test for performance once installed.

Description

Up to 30% of the energy used to heat and cool a building can be lost through leaky ducts and poor duct design. In buildings where a central furnace or boiler serves multiple units, duct design, placement and sealing are crucial for achieving desired performance and comfort. For residences with heating and/or air-conditioning systems in each unit, duct design can greatly affect performance and energy costs for the occupants.

With forced-air heating and cooling systems, the return ducts deliver air back to the heating and cooling system for conditioning. Typically, equipment is designed to condition return air that is at or near room temperature. Leaky return ducts allow cold air in the winter and hot air in the summer to be drawn from the outdoors back into the heating/cooling system, reducing efficiency.

Ducts in exterior walls, attics and un-insulated spaces can also lose a significant amount of heated or cooled air to the outside through conduction. This is especially true in spaces served by long duct runs, where the conduction losses can be even greater. Long duct runs usually correspond with numerous bends, where dust can build up and further hinder efficiency.

Often, distribution systems are oversized to supply enough conditioned air to overcome losses from leaks, conduction, and configuration problems.

Benefits

Well-designed duct distribution systems reduce energy costs, improve comfort, and may allow for smaller HVAC equipment to be installed.

Duct testing can uncover potential problems in leakage and distribution, and may cut maintenance costs by reducing complaints about heating and cooling inconsistencies.

Application

Duct effectiveness measures are applicable wherever a forced-air HVAC system is used (*Systems: Measure 03—High-Efficiency Heating*).

Design Details

For maximum effectiveness, design duct layout and chases early. Proper design, especially in an already energy-efficient building, may allow for equipment downsizing. Strategies include:

- » Minimize duct runs by locating registers close to the core of the building and away from windows.
- » Consider the length and size of ducts as a function of the overall heating and cooling system size (model air flow using Manual D and/or J calculations).

- » Locate ducts in conditioned areas of the home, by constructing a ceiling plenum in hallways or between floors on a multistory building.
- » Use only mastic to seal duct joints and around bends in elbows.
- » Keep duct runs short with few bends. Install dampers at start collars. Use turning vanes at 90-degree turns. Encourage the use of metal plenums and ducts.
- » Insulate all ducts located in unconditioned areas (attics, crawl spaces, exterior walls) to R-8. For ducts located within the conditioned envelope, insulating to R-4.2 is adequate.

Duct effectiveness is verified by a certified home energy rater (such as CHEERS, see *Planning & Design: Measure 11—ENERGY STAR® Certified Homes*). These raters perform a test to measure leakage and temperature changes. HERS rating is an integral part of achieving ENERGY STAR® certification.

STANDARD AIR DISTRIBUTION SYSTEM

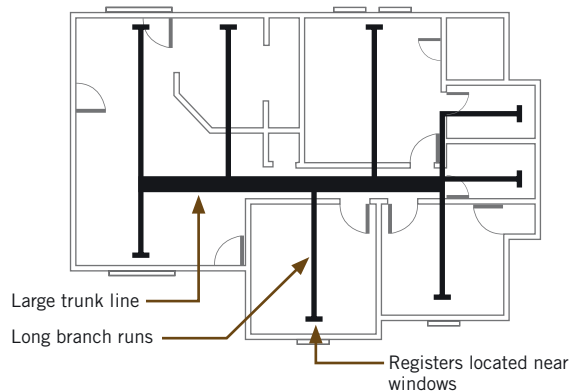

HIGH-EFFICIENCY AIR DISTRIBUTION SYSTEM

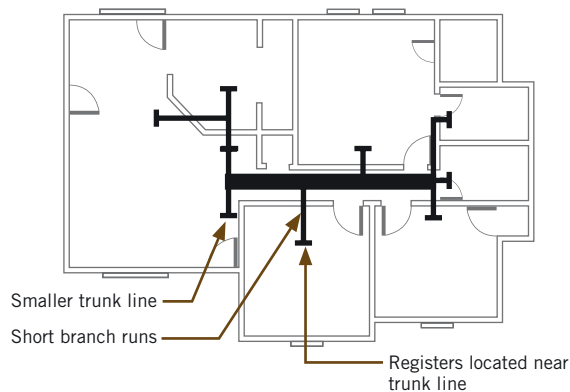

Efficient duct design and placement can result in simpler systems with lower energy use. The top illustration shows a perimeter ducted system. In buildings with increased insulation, short duct runs to the center of the building will supply ample heating while reducing materials and heat losses.

Code Considerations

Sealing ducts with mastic will be required by California's Title 24 in 2005. Insulating ducts to R-4.2 is already a requirement for all ducts conveying conditioned air, except when ducts are located within the conditioned space.

When the 2005 Title 24 Standards go into effect, all ducts will most likely be required to be insulated to above R-4.2. Adopt this practice now to stay a step ahead of the code change.

To obtain an ENERGY STAR® home rating, the ducts need to be tested for performance.

Considerations for Residents

Duct effectiveness may provide health benefits by reducing airborne pollutants such as excess moisture, outside pollution, unpleasant odors, and dust and other particulates from unconditioned areas of the building. Effective duct design and installation also result in quieter operation, reduced energy costs and a more comfortable home.

Cost and Cost Effectiveness

| | | |
|----------------|--------|--|
| BENEFIT | ★★★ | Duct testing and sealing during construction is highly cost effective, saving between 10% to 20% of the HVAC operating costs for the life of the building, for a one-time cost of about \$250 per unit. That cost may be offset by rebates available for ENERGY STAR® certification (for more on incentives for home energy testing, see <i>Planning & Design: Measure 11</i>). |
| COST | \$\$\$ | |

Appropriate duct sizing and placement within the conditioned space can cut costs through reduced materials and labor and downsized equipment. Investing in the proper design of ducted systems will result in better performance, thus saving energy.

Increasing insulation above minimum code requirements can be done for a nominal fee.

Resources

- » U.S. EPA's ENERGY STAR® website and hotline offer fact sheets on duct sealing and insulation, and more: Tel. (888) 782-7937 www.energystar.gov
- » California Home Energy Efficiency Rating System (CHEERS) website lists duct testing companies: www.cheers.org
- » PG&E offers rebates: www.pge.com

ADVANCED VENTILATION PRACTICES

Strategies for Reduced Air Infiltration and Natural and Mechanical Ventilation

| WHO | KEY BENEFITS |
|---|--|
| <ul style="list-style-type: none"> ✓ Developer/PM ✓ Funder ✓ Policymaker ✓ Architect ✓ Builder ✓ Resident ✓ Building Manager | <ul style="list-style-type: none"> ✓ Health/IEQ ✓ Site/Community ✓ Energy Efficiency ✓ Water Efficiency ✓ Material Efficiency ✓ O&M ✓ Resident Satisfaction ✓ ENERGY STAR® |

15830: Fans, 15900: HVAC Instrumentation and Controls

Recommendation

Build residences that are tightly sealed to increase energy efficiency.

Provide natural and mechanical ventilation as needed to ensure enough fresh air is circulated for health reasons and to balance pressure differences inside and outside the home.

Description

Today's residential buildings are constructed more tightly than homes in the past. But air leakage still accounts for up to 25% of the heating and cooling energy used by typical residence. In high-performance buildings, like ENERGY STAR®-certified homes, reducing air leaks is a primary strategy for saving energy.

Tighter construction does affect ventilation, however. In the past, leaks due to infiltration provided enough ventilation to circulate fresh air. In tighter buildings, ventilation systems may be necessary to provide adequate air changes.

Tighter construction and imbalanced forced air HVAC systems can cause significant differences in pressure from outside to inside. Temperature and wind on the outside constantly change the ambient pressure, causing drafts and leaks. Residents may notice doors slamming shut behind them, or air being pulled under doorways. In unusual cases, these pressure differences can cause backdrafting, a potentially life-threatening condition where fumes from combustion gas appliances are sucked back inside the home rather than being exhausted to the outside.

Proper ventilation strategies ensure the building is tight and energy efficient, while allowing for adequate air changes and compensating for pressure differences.

Benefits

Sealing air leaks results in a more energy-efficient building and can improve acoustical performance. Ventilation (natural or mechanical) allows the building to receive fresh air and improves indoor air quality by exhausting stale or polluted air.

Application

Applicable to all new homes and major renovations.

Design Details

REDUCED AIR INFILTRATION

The most common leakage spots in new homes include sill plates, top plates, electrical and plumbing penetrations, boxes around windows, duct penetrations, attic hatches, recessed light fixtures and door frames.

Weatherstripping, house wraps, sealants, foams and tapes are common solutions to reduce infiltration. Use foam to seal penetrations between floors through top plates, plumbing and electrical penetrations (*Finishes & Furnishings: Measure 03—Adhesives and Sealants*). Seal ducts with mastic (*Systems: Measure 09—Duct Effectiveness*). (For more on house wraps, see *Planning & Design: Measure 12—Moisture Shedding and Mold Avoidance*.)



Sealing around penetrations in the building envelope reduces infiltration.

Additional strategies for reducing infiltration include:

- » Caulk or use foam spray around all penetrations.
- » Seal any hole going from a living space to an attic, including inside-the-wall plates.
- » Seal all penetrations to the outside between floors and stud cavities.
- » Use foam sealing in vertical penetrations between floors and lateral penetrations between stud cavities.
- » Isolate residential units from one another to limit air flow between floors. This reduces leaks and helps protect air quality (for example, by keeping a neighbor's cigarette smoke out of the unit).

NATURAL VENTILATION

With affordable housing, most funders require operable windows. Windows help provide natural ventilation even if there are only one or two exterior walls. To promote natural ventilation, locate windows to take advantage of prevailing winds and use a combination of low and high windows to induce cross-ventilation (*Systems: Measure 07—Avoid Air Conditioning*). Also consider passive solar features: south-facing windows help with solar heating and provide good ventilation when coupled with north-facing operable windows (*Systems: Measure 01—Passive Solar Heating*). Some window manufacturers include small operable vents in the window frames to provide fresh outdoor air without opening the window.

MECHANICAL VENTILATION

Mechanical ventilation requires a continually operating exhaust fan, usually located in a hallway. This is in addition to standard bathroom and kitchen exhaust fans. An independent supply system can also be installed to negate pressure differences caused by the exhausting system, and to provide fresh air. Supply ventilation systems should provide as much air as is being exhausted to neutralize pressure differences, and to eliminate the risk of backdrafting. Locate intakes away from sources of pollution, odor and dust, such as areas where smoking, barbecuing, idling trucks, garbage and garages are present.

To minimize pressure differences inside the home, provide transfer grilles between rooms where necessary. This is commonly done in single-family homes, but it can be an acoustical concern.

Some mechanical ventilation systems have an air-to-air heat exchanger to capture some of the energy lost through exhausted air (these are also called heat recovery ventilators or energy recovery ventilators). These are often not cost effective in the San Francisco Bay Area's mild climate.

Once the home is built, a Home Energy Rater can perform a blower door test to measure infiltration leakage and ventilation duct efficiency (*Planning & Design: Measure 11—ENERGY STAR® Certified Homes*).

Code Considerations

Infiltration sealing is standard practice in California but ensuring it is done effectively requires diligence. Leakage tests can identify problem areas (*see above*).

Considerations for Residents

Reducing infiltration will cut heating and cooling costs. Natural and mechanical ventilation will help maintain healthy indoor air quality.

Cost and Cost Effectiveness

| | | |
|----------------|--------|--|
| BENEFIT | ★★★ | Sealing against infiltration is an important aspect of quality home building. Most contractors do some sealing, but taking extra care will provide a better quality home. This may increase labor costs. |
| COST | \$\$\$ | |

Natural ventilation requires good design, which may add first costs by increasing design time. To maximize this design time investment, look for synergies with other green measures elsewhere in the building, with the goal of reducing costs in some areas to pay for other upgrades.

Mechanical ventilation systems cost extra because they are independent systems that require ductwork and fans. Supply air systems with filters are relatively inexpensive compared to other HVAC equipment, at about \$400 per unit.

It is the residents who ultimately determine the efficiency of a mechanical ventilation system. Have an orientation program in place for residents so that they fully understand how to take advantage of the building's features (*Operations & Maintenance: Measure 01—Trainings and Manuals*).

Resources

- » **Building Science Corp.'s** report, "Healthy and Affordable Housing: Practical Recommendations for Building, Renovating and Maintaining Housing," discusses proper sealing (*also see their publications on strategies to avoid backdrafting, mold and more*): www.buildingscience.com
- » **BuildingGreen** lists energy and heat recovery ventilators: www.buildinggreen.com
- » **ENERGY STAR®** has fact sheets about infiltration reduction and ventilation systems: www.energystar.gov/homes
- » **ACWMA's** Materials Database lists products that correspond with this measure: www.multifamilygreen.org

GARAGE VENTILATION

Design Parking Structures for Safe Air Quality and Low Energy Use

| WHO | KEY BENEFITS |
|---|--------------------------------|
| ✓ Developer/PM Funder Policymaker | ✓ Health/IEQ Site/Community |
| ✓ Architect | ✓ Energy Efficiency |
| ✓ Builder | Water Efficiency |
| Resident | Material Efficiency |
| ✓ Building Manager | ✓ O&M |
| | ✓ Resident Satisfaction |
| | ✓ ENERGY STAR® |

Recommendation

Design naturally ventilated parking structures with appropriate measures to avoid indoor air pollution from car exhaust.

When mechanical ventilation is necessary, use demand controls to reduce fan use.

Description

Parking structures must maintain safe air quality. To do this, they often use large, energy-consuming fans that may run 24 hours a day. A better solution is to design open parking structures that allow for air flow and natural ventilation. Partial walls with openings for steel mesh may be used to screen the view of cars and provide security.

When mechanical ventilation is required, install carbon monoxide (CO) sensors to control the fans. This is called demand-control ventilation, and has the potential to save 50% to 90% of the energy used by the fans for very little up-front cost.

In addition to ensuring that the air quality within parking structures is safe, there are concerns about occupant health from underground and ground-floor parking structures. Indoor air quality (IAQ) can be compromised from car exhaust seeping into adjacent units. Noise pollution from cars and car alarms can also be a problem.

Strategies that address IAQ concerns through proper ventilation and air sealing can reduce exhaust problems (*Systems: Measure 10—Advanced Ventilation Practices*). Also, well-insulated buildings will cut down on noise pollution from cars (*Structure: Measure 09—Insulation*). Adequate visibility, parking spacing, and lighting will reduce security concerns (*Planning & Design: Measure 06—Design for Safety*).

Benefits

Naturally ventilated parking under buildings can result in quieter, better quality ventilation than fans can provide because more volume of air from breezes and open walls results in cleaner air.

Demand controls used with mechanical ventilation save fan energy.

Application

Applies to below-grade, tuck-under, and ground-floor parking garages (*for above-ground parking issues, see Planning & Design: Measure 10—Stormwater Management*).

Design Details

Before designing the parking structure, consider how neighborhood aesthetics and access could be affected with an enclosed garage. Pedestrian access and street-level retail or housing could be compromised (*Planning & Design: Measure 01—Infill Sites / Planning & Design: Measure 04—Design for Walking and Bicycling*).

REDUCE INFILTRATION

Air pollution from parking garages can enter living spaces if a pathway is present. Seal all penetrations to the building envelope with caulk, sealants and weatherproofing, especially on the floor adjacent to parking spaces. Caulk and tape drywall joints carefully in these areas. Thermally isolate the units from the parking area.

Consider locating entrances to housing away from the parking area, or seal corridors and hallways from drafts. Double-door entrance assemblies with weatherstripping work well, especially in corridors. Also, consider positively pressurizing the entryways and corridors to reduce drafts through the building (*Structure: Measure 10—Advanced Ventilation Practices*).

PROVIDE NATURAL VENTILATION

Natural ventilation in parking areas can be done through openings in the perimeter walls in tuck-under or below-grade parking. Using semitransparent barriers at the wall openings, such as vandalism-proof grating, fencing and trellises, will allow air to enter and circulate in the parking area. The security grating can be nearly opaque to block views into the garage, if necessary.



This tuck-under garage allows for natural ventilation with minimal visual impact.

USE DEMAND CONTROLS WITH MECHANICAL VENTILATION

If necessary, underground parking facilities can be mechanically ventilated by using continuously operating fans that exhaust air to the outside. These fans are relatively inexpensive to purchase, but can be costly to operate. Consider specifying a demand-control ventilation system with a CO sensor instead of a

continuous fan. The CO sensor will activate the fans when a threshold is met, and shut them off once the contaminants have been exhausted to safe levels.

Often these fan systems will run only a fraction of the time a constant fan will operate, saving significant energy and reducing noise. Take care to place exhaust fans away from residential windows and air intakes so they do not pollute residences.

Code Considerations

Garage ventilation must comply with minimum air changes per hour and other ventilation standards set by the state and other jurisdictions.

Considerations for Residents

Occupants will benefit from healthier indoor air quality and a quieter building.

Cost and Cost Effectiveness

| | | |
|----------------|--------|--|
| BENEFIT | ★★★ | Adding ventilation strategies that promote good IAQ should not add significant costs. A demand-control ventilation system typically pays for itself in less than a year. |
| COST | \$\$\$ | |

DAYLIGHTING

Illuminate Spaces with Natural Light

| WHO | KEY BENEFITS |
|---|--|
| <ul style="list-style-type: none"> ✓ Developer/PM ✓ Funder Policymaker ✓ Architect ✓ Builder Resident Building Manager | <ul style="list-style-type: none"> ✓ Health/IEQ Site/Community ✓ Energy Efficiency Water Efficiency Material Efficiency ✓ O&M ✓ Resident Satisfaction ENERGY STAR® |

Recommendation

Provide daylighting through windows, skylights and glazed doors to all regularly occupied spaces.

Description

Good daylighting creates a pleasant atmosphere, and is thought to elevate people’s moods. There are different theories as to why this effect on mood occurs, including the color and spectrum of light, the variable brightness levels of daylight, and the connection it provides to the outdoors.

Daylighting can also reduce the need for electric lighting—without adding significant construction costs or requiring additional square footage. Windows can be arranged to allow light to penetrate deeper into spaces and increase daylighting.

Benefits

Daylighting can save energy by reducing the use of electric lighting. Daylighting provides high quality light that is clinically proven to elevate moods and reduce depression.

Application

Daylight can provide quality, even illumination suitable for most tasks without the use of electric light. Daylighting in homes is typically done through side lighting (windows) and top lighting (skylights or tubes).

Daylighting in common areas can be achieved through view windows, clerestory windows and skylights. For areas where detail tasks are performed, such as reading and computer work, control glare by providing reflected or diffuse lighting with shading devices, light shelves or tinted glazing, and with atrium or courtyard designs that block direct light.

Design Details

Daylighting design must be incorporated early in the design process when building placement and orientation are being determined (*Planning & Design: Measure 03*). Other green building elements, like ENERGY STAR® Homes (*Planning & Design: Measure 11*), passive solar heating (*Systems: Measure 01*), natural ventilation (*Planning & Design: Measure 10*), and window type (*Structure: Measure 13*) are directly related to daylighting.

GENERAL SEQUENCE OF DAYLIGHTING DESIGN

1. Consider the local climate, building orientation and relationship to surrounding structures and trees. How will sunlight fall on the building? Where are the potential glare issues? North light is ideal for daylighting with windows because it provides glare-free, indirect light. Depending on site wind patterns, window placement for daylighting can coincide with natural ventilation strategies (*Planning & Design: Measure 03—Building Placement and Orientation / Systems: Measure 10—Advanced Ventilation Practices*).
2. Consider the size and location of the windows, keeping in mind the basic guidelines shown in the diagram below. One inexpensive technique for getting daylight deep into a room is to use high windows (with a raised sill) that reach nearly to the ceiling. Another way to increase both daylighting and natural ventilation opportunities is to use single-loaded corridors, with residential units along only one side of the corridor.

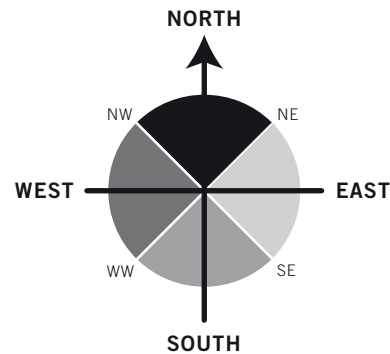

Basic guidelines for window size, location and overhangs.

NORTH

Medium to large windows for daylighting and views
Regular or high sills are okay
Overhangs for rain protection only

WEST

Small or no windows to minimize heat gain and glare
Use light shelves and reflected light wherever possible
Regular sill height
Overhangs for rain protection only
Consider side fins and walls where windows are essential

EAST

Small windows to minimize heat gain and glare
Best in bedrooms
Regular sill heights
Overhangs for rain protection only

Consider side fins and walls where windows are essential

SOUTH

Medium to large windows for daylighting, heating and views
High sills are best
Use light shelves and reflected light for daylighting
Overhangs are critical for controlling heat gain

3. Consider how to use exterior building shading elements. Size overhangs on the south wall to shade a majority of the window area in summer and none of the window area in winter. In general, keep windows on the east and west walls as small as possible. Side fins and wing walls may be effective for east and west exposures if larger windows are needed.
4. Consider how interior shading elements will be used. These include curtains, drapes and blinds, as well as light shelves that bounce daylight deep into a room. While light shelves are not normally needed in multifamily projects because of the shallow floorplate depth, they may be useful for the ends of central corridors and other common spaces. Bouncing daylight off light-colored walls and ceilings reduces glare, and gets light further into a room (for the solar absorptance of common finish colors, see *Systems: Measure 02—Thermal Mass Flooring*).
5. Consider adding skylights wherever windows cannot provide sufficient daylight or where ventilation needs are highest, such as at the top of a stairwell. Tubular skylights are excellent for bathrooms and halls on the top floor. Select products that are well insulated to improve efficiency.
6. Select photocell controls for nonessential electric lighting.
7. Consider electrical lighting design in conjunction with daylighting to avoid unnecessary electrical configurations.
8. Consider visible transmittance (VT) when selecting windows. VT is the amount of light passing through the glass. Higher VT values allow in more light, but if the glazing doesn't have a spectrally selective coating such as low-e, a higher VT can increase cooling loads (*Structure: Measure 13—High-Performance Windows*).



Daylighting in common area (with natural linoleum floors).

Code Considerations

| | | |
|----------------|--------|--|
| BENEFIT | ★★★ | Title 24 allows a maximum of 40% window-to-wall ratio (WWR) for high-rise residential buildings over three stories. WWR is the ratio of the square footage of glazing on exterior walls to the square footage of the exterior wall area. |
| COST | \$\$\$ | |

Residential buildings three stories and under are required to have a fenestration percentage below 16% (climate zone 12) or 20% (climate zone 3). Fenestration percentage is the square footage of window and skylight areas divided by the building's total floor area, then multiplied by 100.

In either case, the energy code punishes buildings with large window areas.

Considerations for Residents

Daylighting has a profound effect on a building's occupants. In general, people feel better in naturally lit spaces, and clinical studies have linked daylit buildings with reduced depression (see *Resources* section). Residents may also benefit from reduced energy bills.

Cost and Cost Effectiveness

In most cases, a basic level of daylighting can be provided for no increase over standard construction costs. Adding skylights or tall windows may increase costs. Deep overhangs or awnings are likely the most expensive elements of a daylighting design, but costs range widely. Light shelves, automatic lighting controls and specialized glazing strategies are more common in office buildings. They can significantly increase costs.

Resources

- » **PG&E's Pacific Energy Center** has a heliodon for analyzing the effects of daylight on a scale model: www.pge.com/pec
- » **Collaborative for High Performance Schools (CHPS)** Best Practices Manual, (Vol. 2—Design) describe studies that correlate daylighting with improved student test scores, worker productivity, and retail sales. CHPS daylighting design strategies, while intended for school buildings, are also applicable to multifamily housing: www.chps.net
- » **San Francisco Department of the Environment** has compiled information on productivity and the effects of daylighting on moods. To download "Green Buildings and Worker Productivity: A Review of the Literature," go to www.sfenvironment.com and search on "mood."

Software programs can model the effects of daylight in a space. Search ACWMA's Materials Database for product information: www.multifamilygreen.org.

HIGH-EFFICIENCY LIGHTING

Specify Linear and Compact Fluorescent Lamps

| WHO | KEY BENEFITS |
|---|--|
| <ul style="list-style-type: none"> ✓ Developer/PM ✓ Funder ✓ Policymaker ✓ Architect ✓ Builder ✓ Resident ✓ Building Manager | <ul style="list-style-type: none"> ✓ Health/IEQ ✓ Site/Community ✓ Energy Efficiency ✓ Water Efficiency ✓ Material Efficiency ✓ O&M ✓ Resident Satisfaction ✓ ENERGY STAR® |

DIVISION 16: Electrical

Recommendation

Specify linear (tubular) T8 fluorescent lamps and compact fluorescent lamps (CFL) with electronic ballasts for all high-use interior lighting.

Specify only LED exit lights. If linear lamps are used, specify low-mercury products.

Description

Fluorescent lighting is energy efficient and cost effective. It has historically suffered from a reputation of poor quality, but newer fluorescent lamp and electronic ballast technologies have remedied earlier shortcomings. New products have eliminated flicker, deliver instant start times, and provide vastly improved color rendition.

All fluorescent lamps contain mercury, an environmental toxin. It is expensive to recover mercury from spent lamps, so specify low-mercury lamps to avoid this end-of-life issue. Some manufacturers now offer fluorescent lamps (linear and CFL) that contain only a fraction of the mercury used in standard fluorescent lamps.

For disposal questions related to lamps and ballasts, refer to Alameda County Waste Management Authority's *Builders Guide to Reuse and Recycling*. Lamp and ballast disposal are also addressed in the *Alameda County Recycling Guide* (see *Resources section*).

Some newer fluorescent lamps can be dimmed like traditional incandescent lamps. This gives more flexibility in designing for daylighting or “mood” lighting, especially in common areas.

Benefits

The price of good quality CFLs is still much higher than simple Edison-base incandescent bulbs, but the payback is quite good. Fluorescent lamps produce three to four times as much light per watt than incandescent lamps, saving energy and money over the life of the lamp. And the lamps last up to 10 times longer.

For example, a typical 20W CFL produces a comparable amount of light to a 75W incandescent bulb and will save \$40 in energy costs over its lifespan.

LED exit signs consume between 2 and 4 Watts, as compared to compact fluorescent (15W), or incandescent (20–40W) exit signs.

Application

T8 lamps and CFLs have typically been installed in kitchens and bathrooms due to code requirements for residential housing. They are suitable for use in all rooms, garages and outdoor porch lighting.

Hard-wired CFLs can be installed in bedrooms and in recessed fixtures. Wall sconces with CFLs are practical in hallways and bedrooms.

LED exit signs are nearly standard practice today, and replace fluorescent and incandescent fixtures in all applications.

Design Details

Use CFL or T8 fixtures instead of incandescent fixtures. Low-mercury fluorescent lamps with flicker-free electronic ballasts and high CRI lamps are recommended in every fixture (see *table on next page*).

In areas that do not have lighting requirements, such as bedrooms, adding a ceiling-mounted CFL fixture will further save energy.

To ensure that residents will continue to use fluorescent lamps, use pin-based CFLs that plug into a special fixture rather than screw-in CFLs with a standard Edison base. Hard-wired CFLs cannot be retrofitted with typical incandescent bulbs, which increases the likelihood of long-term energy and cost savings.

LIGHTING CONTROLS

Lighting controls can significantly reduce lighting energy use, especially in common areas. Occupancy sensors (passive infrared, ultrasonic, or both) are a sure way to reduce energy use. Install them in closets and rooms that will only be occupied intermittently. Occupancy sensors in rest rooms and bathrooms will also cut energy use, but be sure to position them so that they will sense the presence of someone in a toilet stall.



Wall occupancy sensor.

Photocells, which control electric lighting in response to outdoor light levels, can also save energy. They are typically used to shut off exterior lights during the daytime and automatically turn on the lights at night. Photocells are also used in conjunction with daylighting design to provide high quality illumination indoors during daytime hours (*Systems: Measure 12—Daylighting*).

LIGHTING TERMINOLOGY AND RECOMMENDATIONS

| TERM | DEFINITION | RANGE | FLUORESCENT LAMP RANGES |
|---|--|-------------------------------|--|
| Color Rendering Index (CRI) | A measure of how accurate colors appear under the lamp | 1–100 (higher is better) | >80 is considered high color rendering |
| Recommendation: Choose CRI > 80 | | | |
| Lumens | A measure of light emitted by a lamp | 10–80+ lumens per watt (lm/W) | 50+ lm/W |
| Correlated color temperature (CCT) | A classification of a light's color in Kelvin (K) | 0–5000K+ | 2000–3000K: yellow to red 4000K: bright white 5000+: blueish |
| Recommendations: ~2700K creates an intimate environment for homes ~3500K is friendly & inviting; good for offices, public reception areas ~5000K is bright and alert; useful for seniors who function better with a bluer light | | | |

Code Considerations

Current Title 24 standards require fluorescent lighting for kitchens and bathrooms. Until 2005, some leniency exists for replacing fluorescent lamps with incandescent or halogen lamps where high visual acuity is needed. However, in 2005, virtually all interior residential hardwired lighting must be either high efficiency lighting (fluorescent) or use specific controls.

Considerations for Residents

Thanks to improvements in fluorescent lamp technology, residents can now expect better interior lighting with more natural color rendition. Electronic, flicker-free ballasts will also increase acceptance of fluorescent lighting inside a home. Energy and money savings from fluorescent lamps make them very attractive to occupants.

Specifying fixtures with lamps available at local hardware stores will help maintain savings over the life of the building. If residents need to special-order lamps, they may instead replace the fixture with one that uses incandescent lamps.

Cost and Cost Effectiveness

| | | |
|----------------|--------|--|
| BENEFIT | ★★★ | Standard T8 lamps cost about \$2.00 each; low-mercury T8s cost about \$2.30. Electronic ballasts for T8s cost about \$18 each. |
| COST | \$\$\$ | |

New hard-wired CFL fixtures range from \$15 to \$200. Hard-wired pin based fluorescents are more cost effective than screw-in CFLs; the ballast outlasts the lamps, and therefore only the lamp needs to be replaced, which saves money.

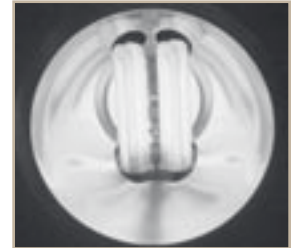

A hard-wired compact fluorescent fixture.

There are now CFLs in the 7W to 26W range that cost as little as \$1.50. Average costs are still in the \$5 to \$10 range. CFLs last 8 to 10 times longer than incandescent lamps; typical payback time is about three years.

LED exit signs cost \$80–\$100 per fixture installed, and will typically pay for themselves within two years.

Dimmable fluorescent lamps require dimming ballasts; expect the cost to be more than triple that of standard electronic ballasts.

Resources

- » **ACWMA** publishes a *Recycling Guide and Builders' Guide to Reuse and Recycling* with information on lamp & ballast disposal. Search the Materials Database for product information: Tel. (510) 614-1699 www.multifamilygreen.org
- » **ENERGY STAR**® has specific criteria for CFLs, including longevity, light distribution performance, and warranties: www.energystar.gov
- » **PG&E** provides rebates for some multifamily energy efficiency measures, including lighting upgrades (for existing buildings only): www.pge.com/res/rebates
- » **PG&E's Pacific Energy Center** offers information, education and resources on energy-efficient electric lighting at their San Francisco facility and online: www.pge.com/pec
- » **Green Seal**, a nonprofit organization that recommends environmentally preferable products, has information on low-mercury fluorescent lamps: www.greenseal.org/recommendations.htm#product
- » **California Title 24 2005** Building Energy Standards for residential lighting, Section 150 (k) can be downloaded from: www.energy.ca.gov/2005_standards/rulemaking/documents/15-day_language/2003-10-21_400-03-001-ET15F.PDF
- » **INFORM** has fact sheets on mercury in lamps: www.informinc.org/fact_P3mercury_lamps.php

LIGHT POLLUTION REDUCTION

Design Outdoor Lighting to Minimize Glare and Light Pollution

| WHO | KEY BENEFITS |
|---|--|
| <ul style="list-style-type: none"> ✓ Developer/PM Funder Policymaker ✓ Architect ✓ Builder Resident ✓ Building Manager | <ul style="list-style-type: none"> Health/IEQ ✓ Site/Community ✓ Energy Efficiency Water Efficiency Material Efficiency O&M ✓ Resident Satisfaction ENERGY STAR® |
| 16520: Exterior Luminaries | |

Recommendation

Select exterior lighting fixtures that have the minimum light output necessary for safety and visual acuity, and shield fixtures to keep excess light from leaving the site.

Description

Light *pollution* occurs when outdoor light fixtures let excess light escape into the night sky. Light *trespass* occurs when fixtures let light spill onto neighboring properties.



Light pollution from buildings reduces views of the night sky and wastes energy.

Glare occurs when a light source is significantly brighter than the luminance that the eyes are adjusted to at night. Glare is a nuisance and it reduces visibility and perception.

Overlighting an outdoor area at night isn't the best solution for either security or safety. Instead, exterior lighting that provides low contrast on critical areas and

surfaces (such as sidewalks and parking areas) can actually provide better visual acuity. The light color of lamps also affects safety: illuminating objects with products that have high Color Rendering Indexes (CRI) improves visual recognition of people and objects at night (*Systems: Measure 13—High-Efficiency Lighting / Planning & Design: Measure 06—Design for Safety*).

Benefits

- » Saves energy (reducing light pollution often involves using lower-wattage fixtures and lighting controls to illuminate areas only where and when needed)
- » Reduces light trespass, improving relations with neighbors
- » Preserves nocturnal habitats for animals
- » Keeps the night sky dark enough to view stars

Application

The need to control light pollution and glare differs depending on whether the building is in an urban or rural area. The following table shows the U.S. Green Building Council's summary of Illuminating Engineering Society of North America's (IESNA) guidelines for designing exterior lighting in various environments. This table provides general guidance; unique site constraints may affect the ability to design to these levels.

| ZONE | DESCRIPTION | RECOMMENDED MAXIMUM ILLUMINANCE LEVELS* <small>in footcandles (FC)</small> |
|---------------------------|---|---|
| Intrinsically Dark | Parks and Residential areas where controlling light pollution is a high priority | 0.1 |
| Low Ambient Brightness | Outer urban and rural Residential areas | 0.1 |
| Medium Ambient Brightness | Urban Residential areas | 0.2 |
| High Ambient Brightness | Urban areas having both Residential and commercial use and experiencing high levels of nighttime activity | 0.6 |

*Illuminance values are measured at the eye on a plane perpendicular to the line-of-sight

The goal should always be to minimize lighting to the greatest extent possible while providing safety with low contrast and good color rendering.

Design Details

First focus on avoiding outdoor lighting where it is not needed. Where lighting is needed, keep the brightness to an appropriate level. Use valances and overhangs wherever horizontal light should be controlled, and specify fixtures with full cutoff to avoid uplight or glare. Eliminate all unshielded fixtures, such as floodlights.

DEFINITIONS

- » Shielding describes techniques and devices that limit light pollution and trespass. Shielding occurs by tucking lights under overhangs, or by using fixture covers that control glare or direct light downward.
- » A full-cutoff luminaire has zero candela intensity at an angle of 90 degrees above the vertical axis (nadir) and at all angles greater than 90 degrees from nadir.

GUIDELINES FOR REDUCING LIGHT POLLUTION

- » Specify white HID or compact fluorescent lamps that give reasonable color rendition at low brightness.
- » Shield all lamps that have an initial lamp brightness greater than 1000 lumens. Fixtures with initial lumens greater than 3500 should meet IESNA's guidelines for full cutoff (*see Resources section*).
- » Minimize or eliminate feature lighting, such as lighting architectural embellishments or signage. When necessary to highlight details or features, use downlighting instead of uplighting.
- » Turn off all nonessential lighting after normal operating hours, or use motion sensors, photocells or time clocks to control lighting.
- » For parking lots, specify shorter, lower wattage fixtures. Increase the number of fixtures and place them closer together. This decreases losses from glare reflection and overlighting, while providing uniform light and making maintenance less costly.
- » After installation, commission fixtures to verify that lights are directed properly and are performing as intended.

Code Considerations

Code requirements for safety always override this measure, but generally the strategies recommended here are acceptable to code officials. On some projects, conditions of approval may require following these or similar guidelines to avoid neighbors' complaints.

Considerations for Residents

Low-contrast exterior lighting can actually improve safety and lighting quality compared to an overlit environment. Many people believe that high levels of exterior lighting are needed at night to provide safety and security. However, it's the *quality* of lighting that has a large impact on safety. Low-power lighting that uniformly illuminates the necessary areas can be just as effective as non-directional general lighting. Also, light color is as important for visual acuity as brightness, especially for seniors.

Cost and Cost Effectiveness

| | | |
|---------|--------|---|
| BENEFIT | ★★★ | Generally, the capital cost savings from using lower wattage fixtures and shorter poles for parking lots more than offsets the additional costs of full-cutoff luminaires or add-on valances. Parking lot poles 16-feet or less can be serviced at lower cost without a cherry picker. Lower light levels also reduce energy costs. |
| COST | \$\$\$ | |

Resources

- » **Illuminating Engineering Society of North America (IESNA)** has developed the *Recommended Practice Manual: Lighting for Exterior Environments* (IESNA RP-33-99) and *Lighting for Parking Facilities* (RP-20-98):
www.iesna.org
- » **International Dark-Sky Association** addresses light pollution and trespass:
www.darksky.org
- » **New England Light Pollution Advisory Group (NELPAG)** has information about light pollution:
<http://cfa-www.harvard.edu/cfa/ps/nelpag.html>
- » **LEED Reference Guide 2.1** has details on estimating light pollution and trespass:
www.usgbc.org
- » **ACWMA's Materials Database** lists products that correspond with this measure:
www.multifamilygreen.org

ONSITE ELECTRICITY GENERATION

Consider Generating Electricity On Site with PV, Wind Turbines or Microturbines

| WHO | KEY BENEFITS |
|---|--|
| <ul style="list-style-type: none"> ✓ Developer/PM ✓ Funder ✓ Policymaker ✓ Architect ✓ Builder ✓ Resident ✓ Building Manager | <ul style="list-style-type: none"> ✓ Health/IEQ ✓ Site/Community ✓ Energy Efficiency Water Efficiency Material Efficiency ✓ O&M ✓ Resident Satisfaction ENERGY STAR® |

DIVISION 16: Electrical

Recommendation

Consider generating electricity on site by using photovoltaics, wind energy, microturbines or fuel cells to reduce utility energy use.

Description

Onsite energy generation can provide reduced and fairly constant operating costs compared to ordinary utility use. Some technologies, such as photovoltaics (PV) and wind, are environmentally preferable because they do not consume fuels. But other technologies are also considered green. For example, microturbines provide very efficient power while also preheating domestic water. And fuel cells have extremely low air emissions.

INTERCONNECTED VS. INDEPENDENT POWER

There are two types of onsite or self-generated power: utility interconnected and independent.

- » **Utility interconnected systems** dominate the California market and are recommended. These systems are always connected to the utility grid. When the onsite system is producing power, the utility meter simply slows or spins backward. By staying connected to the grid, these systems do not need to use batteries or energy storage devices (unless uninterrupted power is desired).

Interconnected systems take advantage of a system called net metering, whereby every kWh of energy produced by a PV or wind energy system is credited by the utility to the customer's utility bill. However, if the onsite system generates more power than is needed by the building, the excess is credited at a very low price or not at all. This is because of laws restricting the

sale of self-generated electricity to utilities. Therefore, it is in the best interest of building owners to size systems to avoid producing excess energy on a monthly basis.

- » **Independent power** is often called "off-the-grid." In these applications, batteries store energy produced by the generator. Off-the-grid applications are not recommended for multifamily projects.

ENVIRONMENTALLY PREFERABLE ONSITE SYSTEMS

There are three primary types of environmentally preferable onsite electricity generation: photovoltaics, wind power and microturbines.

- » **Photovoltaics** are the most popular choice in multifamily housing. These systems convert solar energy into electricity when sunlight strikes the PV cells. Electricity is produced as direct current (DC) power. An inverter then transfers DC power from the panels into alternating current (AC) power for residential use.
- » **Wind energy** is harvested using advanced wind turbines. Because wind generators must be mounted at least 25 feet above the ground, they are often not desirable for aesthetic reasons.
- » **Microturbines** are typically natural gas– fueled generators that produce electricity full-time. Popular in the high-tech and medical industries for emergency power, microturbines can be used to run entire housing developments. Some systems use the heat produced during turbine operation to heat water for showers and space heating. This is known as cogeneration, and can help make turbines cost effective.

The next generation of microturbines will use advanced fuel cell technology. Fuel cells have the potential to create clean, reliable energy with no emissions other than steam. Currently, however, costs are beyond the means of most projects.

Benefits

Onsite power generation with environmentally preferred sources reduces both air pollution and demand on the power grid. It is considerably more efficient than centralized power generation because there are virtually no distribution losses. Solar, wind and microturbines should produce reliable power for 25 to 40 years; most systems have warranties of 20 years or more. Once these systems have paid for themselves, the energy they produce is essentially free.

Application

Onsite power generation can supplement utility power or replace it entirely. By combining systems, such as installing both a PV system and a microturbine, a development may be able to generate 100% of its own power on site. (Caution: check with utilities for rules regarding more than one renewable onsite generation system). More common, however, is for a project to generate a portion of its total electricity or heating load, for instance, for common areas or shared facilities.

PHOTOVOLTAICS

For PV to be cost effective, the most important parameter is \$/kW installed. Size, efficiency, orientation and other factors mean little if the system cannot be installed at a reasonable cost (for details, see *Cost and Cost Effectiveness* section).

WIND

The most important parameter for wind energy is determining whether a given site has enough wind potential to be cost effective. If enough wind is available, incentives for wind generation can exceed incentives for a comparably sized PV system. Weather station data is available for many locations in California that show mean wind speeds. Measuring wind at the site is the best method, however, if possible.



These photovoltaic panels are integrated into the building exterior at the Colorado Court affordable housing project in Santa Monica.

MICROTURBINES

Cogeneration is especially effective when combined with a domestic hot water system that also produces space heating (*Systems: Measure 04—Radiant Hydronic Space Heating*). Efficiencies can reach 70% or more, compared to about 30% alone, increasing payback periods.

Design Details



Before considering onsite energy production, focus design dollars on reducing energy use to the greatest extent possible. Energy-efficient buildings will require smaller self-generation systems.

Hire an expert or enlist the help of a nonprofit organization (such as *Cooperative Community Energy*, see *Resources* section) that specializes in onsite systems and procurement to help make the process easier. They can help with sizing a system, working with suppliers, overcoming code and permit barriers, and obtaining rebates. Meet early in the design process with your design team and outside experts to identify goals and budgets for the alternative energy system. Provide information to the project's decision makers to build agreement for incorporating onsite energy generation.

Allow adequate space on plans for the generation system. For PVs, this requires a clear roof area of roughly 100 to 150 square feet for each kilowatt of power. Be sure to reserve space in mechanical rooms for PV, wind and microturbine system components. If a system cannot be installed at the current time, plan for adequate infrastructure (conduit runs and space in mechanical rooms) to supply a system in the future.

Do not mount wind turbines directly to a building without consulting an acoustical engineer; the vibrations can be strong.

Finally, teach residents and staff about the basics of energy efficiency to reduce the demand for onsite power systems (*Operations & Maintenance: Measure 01—Training and Manuals*).

Code Considerations

All self-generation energy systems must pass established code approval processes that include utility interconnection regulations and laws, city or county permits and rebate documentation review.

In urban areas, wind power installations may not be feasible because of height and noise restrictions.

Considerations for Residents

Displays that show energy generated from onsite systems can increase residents' interest and cooperation (*Operations & Maintenance: Measure 02—Educational Signage and Tours*). Residents may benefit from reduced energy costs once the system is paid off.

Cost and Cost Effectiveness

| | | |
|---------|--------|---|
| BENEFIT | ★★★ | Incorporating alternative energy systems can give an affordable housing development a greater chance of being funded by the state tax credit program. |
| COST | \$\$\$ | |

Incentives are available for environmentally preferable onsite generation systems. Systems smaller than 30 kW receive incentives through the California Energy Commission. Systems larger than 30 kW are handled through PG&E's self-generation program. Microturbines powered by natural gas only receive incentives through PG&E's self-generation program. Incentive levels are different for each program and technology.

PHOTOVOLTAICS

- » Market-rate housing. PV incentive programs are available to for-profit developers. These include rebates for equipment and installation costs, as well as state and federal tax credits. PV system costs can range from \$3.00 to \$5.00/Watt installed, depending on complexity, rebate level and other factors. Payback periods can be anywhere from 8 to 15 years.
- » Affordable housing. Rebates are available similar to those for the market-rate sector. However, not all affordable housing developers will be able to obtain the state and federal tax credits directly. Additional TCAC tax credits are available to reduce the payback in affordable housing projects. Paybacks of four to eight years are possible in some instances. Check with the California Energy Commission and PG&E for current incentives and regulations. Financing assistance and consulting may be available to maximize incentives and reduce information-gathering efforts (see *Resources section*).

WIND ENERGY GENERATORS

Rebates for wind energy systems are available. Where wind makes sense (wind speeds are high enough and the political climate allows for wind generators in residential areas), they can be as or more cost effective than photovoltaics (for information on rebates and incentives from the California Energy Commission, see *Resources section*). Paybacks are typically 8 to 12 years.



A microturbine provides power when renewable energy systems are not producing.

MICROTURBINES

According to an article in *Environmental Building News* (October 2000), costs per kW for Capstone microturbines were about \$1,000/kW installed. Including a heat exchanger for cogeneration was estimated to add \$7,000. Therefore, the installed estimate for a 25 kW turbine is \$32,000, plus the cost of hook up (electrical and hot water). Costs for operating the system (purchasing natural gas) must also be considered.

PG&E offers incentives up to \$1000/kW for microturbines fueled by natural gas. Figuring in the cost of supplying natural gas for the turbine is essential to estimating cost effectiveness, and differs for each installation.

Resources

- » **ACWMA** has a Fact Sheet with Financial Incentives for Photovoltaics in Multifamily Housing. Search the Materials Database for product information: www.multifamilygreen.org
- » **Cooperative Community Energy** has a wealth of resources for affordable housing projects seeking PV and other self-generation systems. Can help with procurement, low-interest loans, and identifying businesses to lease the system and take advantage of additional tax credits and incentives: www.cooperativecommunityenergy.com
- » **California Energy Commission**
Contact the Commission for current renewable energy incentive program requirements, funding and eligibility: Hotline: (800) 555-7794
renewable@energy.state.ca.us
www.consumerenergycenter.org

For guidebooks about renewable energy options, see: www.consumerenergycenter.org/erprebate/forms.html

- » **PG&E Self-Generation Incentive Program**
For renewable energy systems over 30 kW, or for microturbines of all sizes:
Tel. (415) 973-6436
selfgen@pge.com
www.pge.com/selfgen

PHOTOVOLTAICS INFORMATION SOURCES

- » **Northern California Solar Energy Association**
www.noricalsolar.org
- » **GRID Alternatives.**
See their Solar Affordable Housing Program:
www.gridalternatives.org

- » **California Solar Center**
www.californiasolarcenter.org
- » **National Renewable Energy Laboratory National Center for Photovoltaics** www.nrel.gov/ncpv
- » **U.S. Department of Energy, Photovoltaics Program**
www.eere.energy.gov/pv

WIND ENERGY RESOURCES

- » See **California Energy Commission** above.
- » **American Wind Energy Association** www.awea.org
- » **U.S. Department of Energy, Wind Energy Program**
www.eere.energy.gov/windandhydro
- » **National Renewable Energy Laboratory Wind Technology Center** www.nrel.gov/wind

MICROTURBINES

- » See **PG&E** above.
- » **California Energy Commission**, “Distributed Energy Resources Guide”:
www.energy.ca.gov/distgen/equipment/microturbines/microturbines.html
- » **Environmental Building News**
October 2000 issue reviews microturbines:
www.buildinggreen.com
- » **U.S. Department of Energy, Distributed Energy Resources Program**, www.eere.energy.gov/der/microturbines.html

ELEVATORS

Specify Gearless Elevators; Use Biodegradable Lubricating Oils

| WHO | KEY BENEFITS |
|---|--|
| <ul style="list-style-type: none"> ✓ Developer/PM Funder Policymaker ✓ Architect ✓ Builder Resident Building Manager | <ul style="list-style-type: none"> Health/IEQ ✓ Site/Community ✓ Energy Efficiency Water Efficiency Material Efficiency ✓ O&M Resident Satisfaction ✓ ENERGY STAR® |
| <p>14200: Elevators, 14285: Biodegradable Hydraulic Elevators</p> | |

Recommendation

Specify gearless AC elevators instead of hydraulic elevators when appropriate.

If specifying hydraulic, traction or geared elevators, use biodegradable lubricating oils instead of petroleum products.

Description

Elevators can account for up to 10% of energy use in buildings. For multifamily applications, elevators are often mandatory for accessibility reasons. Typical elevator installations require significant space and are costly to operate.

In applications where a hydraulic elevator is installed, environmental impacts can be reduced by using plant-based, biodegradable lubricating oil. These fluids breakdown quickly and do not cause as much damage if they leak into the ground as petroleum-based oils.

Benefits

Gearless elevators have several advantages over hydraulic, geared and traction elevators. First, gearless elevators are space efficient and easier to install because they typically do not require a mechanical room or special drilling. Second, they have much smaller motors, which can decrease energy use by up to 50%. Finally, they do not require lubricating oils that can leak and cause groundwater contamination.

Application

Gearless elevators are most appropriate for applications of three stories or more because of cost reasons.

Lubricating oils that are plant-derived can be used in place of most petroleum-based products.

Design Details

Gearless elevators may require extra ventilation to compensate for heat build-up in the control area. Builders will most likely need to be trained on how to install and service the new elevators, as will service and maintenance crews.

Code Considerations

| | | |
|----------------|--------|---|
| BENEFIT | ★★★ | Some interpretations of building codes may not allow for elevators without machine rooms. Check with local code officials. Also, check available size limitations; there may not be a gearless elevator available in the size (weight limit) desired. |
| COST | \$\$\$ | |

Considerations for Residents

Gearless elevators produce a smoother ride than hydraulic elevators.

Cost and Cost Effectiveness

For low-rise multifamily buildings, hydraulic elevators are the least expensive option, but they are very inefficient. For mid-rise buildings (three to four stories and more), gearless elevators are competitive with hydraulic and geared elevators.

Resources

- » *Environmental Building News* has reviews of gearless elevators and a list of biodegradable hydraulic fluids. See especially Vol. 8, No. 7/8 (July/August 1999) for a discussion of KONE's elevator system: www.buildinggreen.com
- » *ACWMA's* Materials Database lists products that correspond with this measure: www.multifamilygreen.org

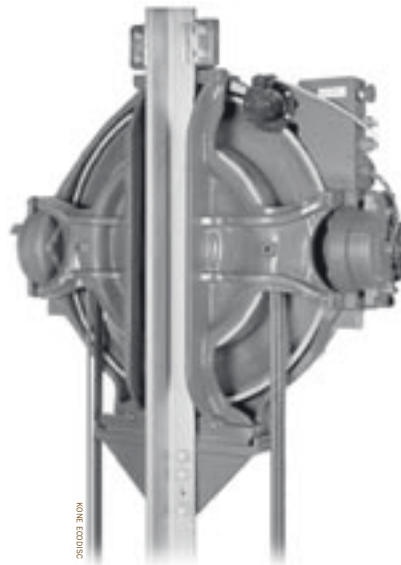

A gearless elevator motor

ENERGY STAR® APPLIANCES

Install ENERGY STAR® Refrigerators, Dishwashers and Clothes Washers

| WHO | KEY BENEFITS |
|------------------|-------------------------|
| ✓ Developer/PM | Health/IEQ |
| ✓ Funder | Site/Community |
| Policymaker | ✓ Energy Efficiency |
| ✓ Architect | ✓ Water Efficiency |
| ✓ Builder | Material Efficiency |
| Resident | ✓ O&M |
| Building Manager | ✓ Resident Satisfaction |
| | ENERGY STAR® |

11450: Residential Equipment

Recommendation

Install ENERGY STAR®-qualified appliances throughout the residential units and common areas.

Description

ENERGY STAR® is a joint program of the U.S. Environmental Protection Agency and the U.S. Department of Energy. It is a voluntary labeling program that aims to reduce greenhouse gas emissions by helping consumers purchase the most energy-efficient products available. Note that ENERGY STAR® appliances are *not* a component of the ENERGY STAR® for Homes rating program (*Planning & Design: Measure 11*).



ENERGY STAR® sets standards for energy efficiency that roughly target the upper 20% of current off-the-shelf technologies. Products that meet the energy efficiency requirements are eligible for the ENERGY STAR® label. In addition to saving energy, many qualified products also save water.

Major home appliances that are eligible for the ENERGY STAR® label include:

- » Refrigerators
- » Dishwashers
- » Clothes washers

Benefits

ENERGY STAR® appliances save money, water and energy. Most of these products are superior in quality and performance to unqualified models. While some ENERGY STAR® appliances may cost more up-front, in general they all cost less to operate over time.

ENERGY STAR® **refrigerators** exceed the stringent 2001 minimum federal standards for refrigerator energy consumption by at least 10%. They are more efficient because they are built better, with high-efficiency compressors, improved insulation, and more precise temperature and defrost control.

ENERGY STAR® **dishwashers** save water heating energy by using an internal water heater to boost temperatures inside the dishwasher, which allows the home's water heater to be reduced to 120°F. This can save significant water heating costs. They also have more efficient motors and advanced sensors that determine the length of the wash cycle and the temperature of the water necessary to clean dishes, allowing for shorter cycles for light loads.

ENERGY STAR® **washing machines** are available in commercial and residential models that use 35% to 50% less water per load of laundry and 50% less energy. These savings are gained by improving moisture extraction from final rinses and matching hot water temperatures to specific loads. Higher water extraction reduces drying time significantly, saving energy. Horizontal (front-loading) models use premium motors and tumble laundry in a low volume of water. Top-loading models use a variety of sophisticated agitators and cycles to achieve water and energy savings.

ENERGY STAR® washing machines also use special low-suds soaps in much smaller amounts than conventional soaps. Some models allow users to use conventional soaps and detergents, while others recommend that only high-efficiency soaps be used.

Application

Install in place of standard home appliances. Consider grouping laundry facilities to get better energy savings, reduce first costs, and save on maintenance costs (*Systems: Measure 18—Central Laundry for information*).

Installing ENERGY STAR® appliances does not contribute to an ENERGY STAR® rating for homes (*for more on ENERGY STAR®-rated homes, see Planning & Design: Measure 11*).

Design Details

Design details are the same as for conventional appliances.

If appliances will be donated, request ENERGY STAR® models. To help compensate the donating manufacturer, offer to promote the benefits of their ENERGY STAR® units as part of the project's public relations efforts.

Code Considerations

Same as standard practice.

Considerations for Residents

ENERGY STAR® saves money by reducing energy and water utility bills. In addition, many ENERGY STAR® appliances work better than their standard counterparts: refrigerators maintain more uniform temperatures; dishwashers heat water to the desired level consistently; and horizontal-axis washing machines are less abrasive to fabric, helping clothing last longer.

Special low-suds soaps may be required for use in high-efficiency washing machines. These soaps cost less per load than conventional soaps and detergents.

Cost and Cost Effectiveness

| | | |
|----------------|--------|--|
| BENEFIT | ★★★ | ENERGY STAR® criteria are developed to be cost effective for the national average cost of electricity, which is substantially lower than California rates. |
| COST | \$\$\$ | |

ENERGY STAR® refrigerators are widely available from most major appliance sources at a cost that pays back in five years or less. They are available in all price and size ranges, from mini units through giant 30 cu. ft units, with the best selection between 18 and 22 cu. ft. The selection in the 14 to 17 cu. ft range is limited.

Qualifying dishwashers cost an additional \$50 to \$200.

Horizontal-axis and advanced top-loading washing machines cost 50% to 60% more than standard washers. They typically pay back after 2,000 loads of laundry (unless the cost of soap is figured in, in which case these units pay back much faster; low-water washing machines use much less soap per wash).

Rebates are frequently available for qualifying appliances, and can offset a significant portion of any incremental cost increases. Check with local utilities for rebate offers. Clothes washers may be eligible for multiple rebates from electric and water utilities.

Resources

- » **ENERGY STAR®** website provides more information and lists products: www.energystar.gov.

REBATES

For rebates for qualifying products in Alameda County:

- » **Pacific Gas & Electric Company**
Tel. (800) 933-9555
www.pge.com
- » **East Bay Municipal Utility District**
Tel. (510) 287-0590
www.ebmud.com

For rebates in other areas, check with the local utility company.

CENTRAL LAUNDRY

Locate Clothes Washers and Dryers in Central Areas

| WHO | KEY BENEFITS |
|--|--|
| <ul style="list-style-type: none"> ✓ Developer/PM Funder Policymaker | <ul style="list-style-type: none"> ✓ Health/IEQ Site/Community |
| <ul style="list-style-type: none"> ✓ Architect Builder | <ul style="list-style-type: none"> ✓ Energy Efficiency ✓ Water Efficiency ✓ Material Efficiency |
| <ul style="list-style-type: none"> ✓ Resident | <ul style="list-style-type: none"> ✓ O&M |
| <ul style="list-style-type: none"> ✓ Building Manager | <ul style="list-style-type: none"> ✓ Resident Satisfaction ENERGY STAR® |

DIVISION 11: Equipment

Recommendation

Save water and energy while fostering community interaction by locating clothes washers and dryers in central areas instead of in individual units.

Use ENERGY STAR®-rated washing machines, or the equivalent, and gas-fueled dryers.

Description

“In-unit laundry facilities used 3.3 times more water for laundry than residents in apartments utilizing common-area laundry facilities.”

Source: 2001 study by the National Research Center, www.laundrywise.com.

The cost of water—and the associated costs of water heating and wastewater treatment—are a significant operating expense for multifamily housing. These costs are likely to increase in the future as freshwater supplies shrink, energy costs escalate, and treatment costs rise.

Residents with clothes washers inside their units tend to wash smaller, less efficient loads more frequently than residents using a centralized laundry room.

A central laundry facility is a simple way to reduce construction costs and promote social interaction among neighbors. Substantial energy and water savings are attained because it is cost effective to purchase or lease

efficient commercial equipment for central facilities. Also, maintaining equipment in central laundry rooms is much less expensive per occupant than maintaining individual appliances. Both coin-operated and card systems are available that, when leased, are maintained by the laundry route operator. And central systems, whether purchased or leased, can provide additional income to the property owner.

Benefits

Centralized laundry facilities save water and energy. High-efficiency washers save more energy than conventional top-loading models (*Systems: Measure 17—ENERGY STAR® Appliances*). Horizontal-axis models spin at higher speeds, improving water extraction and reducing drying time. Commercial-grade horizontal-axis models are easier to service and maintain, thanks to front-mounted components that allow for service without moving the units. Gas fueled clothes dryers save considerable energy (and money) over electric units.

Centralized laundry facilities can encourage social interaction among neighbors, if placed correctly and designed as attractive features instead of as an afterthought.

Application

Centralized laundry facilities are most practical for rental units. For-sale developments tend to prefer independent services to minimize liability and homeowner association dues. There is also a perception that new home buyers want in-unit laundry hook-ups. However, studies by the Multi-Housing Laundry Association (*see Resources section*) show that given the choice of a well-designed and accessible common facility or in-unit hookups, residents prefer the centrally located facility. The appeal is in eliminating the responsibility for and expense of maintaining and operating the equipment.

Design Details

Placing laundry facilities no more than 250 feet from the dwelling units they serve improves their accessibility. In most cases, this means designing multiple, small laundry rooms instead of a large centralized one. Residents prefer smaller and closer facilities; these can usually be incorporated into a building's existing design (no new building or large room is needed). Avoid locating laundry rooms in noisy or uncomfortable areas, such as in mechanical rooms or near garbage bins.

These additional strategies will help centralized laundry work better for occupants:

- » Locate laundry rooms along major foot traffic corridors to encourage interaction and improve safety.

- » Locate laundry rooms next to activity areas, such as workout rooms, swimming pools, community centers or other amenities.
- » Ensure the rooms are well lit and have adequate visibility for security and safety.
- » Keep the areas clean and the machines in good working order. Include a janitor's closet in or near the laundry rooms to make maintenance easier. Use semigloss or high-gloss paint on walls to make them easy to keep clean.
- » Use durable, water-resistant flooring such as colored or stained concrete.
- » Place overflow pans under each washing machine to reduce potential damage if a unit overflows. Three-sided pans can slope toward a central floor drain; four-sided pans should have a drain connected to the plumbing waste line.
- » Keep the cost of doing laundry affordable to occupants.
- » Encourage use by providing amenities such as a television, folding tables, hanging racks and comfortable seating. Use folding stations or tables that can withstand abuse, such as people sitting on them.
- » Ensure that the laundry room has HVAC with controls to provide a comfortable temperature and humidity level.
- » Provide a mix of top- and front-loading washers to accommodate residents' physical abilities (some people may have trouble bending down to reach into a front-loading machine while people in wheelchairs may have difficulty reaching up to use a top-loading machine). Both types of washing machines are available with the ENERGY STAR® certification.

Code Considerations

Central laundry facilities often require airtight fire doors when they are located on every floor. For this reason, and to protect indoor air quality, take special care to properly exhaust all dryers to the outdoors. This will help to control moisture, hot air and lint. Adequate make-up air should be planned for the exhausted dryer air.

Considerations for Residents

High-efficiency laundry machines save drying costs by reducing drying times. High-efficiency washers use low-suds detergents, which reduces the amount of soap needed per wash, saving money. Some reports indicate that these units also wash clothes better than standard units, and prolong the clothes' life.

If laundry facilities are well designed, residents are likely to perceive them as an amenity rather than a hassle.

Many residents prefer card-operated systems rather coin-operated units because of their convenience.

Cost and Cost Effectiveness

| | | |
|----------------|--------|--|
| BENEFIT | ★★★ | Eliminating washer and dryer hook-ups can save about \$2,500 per unit. |
| COST | \$\$\$ | To estimate the cost savings, calculate the cost per square foot of the space used by the individual laundry closets, add the cost of wiring, plumbing a gas line for the dryer, installing a drain, exhausting the equipment, providing ventilation, and maintaining the individual units. Then subtract the total cost of building and maintaining central facilities. |

The combined construction, water and energy savings can offset the cost of high-efficiency washers and dryers. Use dryers fueled by natural gas instead of electricity to further conserve energy and reduce operating costs.

Resources

- » **LaundryWise** provides information supporting the use of centralized facilities:
www.laundrywise.com



- » **LightWash** collaborates with participating California water utilities to offer rebates of up to \$450 per qualifying commercial clothes washer:
www.lightwash.com



A clean, well-daylit laundry facility.

WATER-EFFICIENT FIXTURES

Specify Faucets, Showerheads and Toilets that Use Less Water

| WHO | KEY BENEFITS |
|---|--|
| <ul style="list-style-type: none"> ✓ Developer/PM Funder Policymaker ✓ Architect Builder ✓ Resident ✓ Building Manager | <ul style="list-style-type: none"> Health/IEQ Site/Community ✓ Energy Efficiency ✓ Water Efficiency Material Efficiency ✓ O&M ✓ Resident Satisfaction ENERGY STAR® |
| <p>15425: Sinks & Wash Fountains 15430: Toilets, Urinals & Bidets</p> | |

Recommendation

Specify water-efficient faucets, showerheads and toilets according to the East Bay Municipal Utility District's (EBMUD) recommendations:

- » Kitchen faucets: ≤ 2.0 gpm
- » Bathroom faucets: ≤ 1.5 gpm
- » Showerheads: ≤ 2.5 gpm
- » Toilets: ≤ 1.6 gpf

(gpm = gallons per minute gpf = gallons per flush)

Description

Low-flow faucets, showerheads and toilets that meet the above standard are easy to find and competitively priced.

Benefits

Low-flow fixtures save water and money. In addition, low-flow faucets and showerheads save energy by reducing the amount of hot water used.

Application

Applicable in all projects. Water-saving opportunities in residences include kitchen and bathroom faucets, showerheads and toilets. In common areas, the same opportunities are available; in addition, low-flow or waterless urinals can be installed (*for information about water-efficient clothes washers, see Systems: Measure 17—ENERGY STAR® Appliances / Systems: Measure 18—Central Laundry*).

Design Details

Water-saving fixtures have been around for many years, but many of the first low-flow products were not well designed and performed poorly. As a result, many occupants and installers are skeptical about their reliability and performance. To overcome this perception, specify fixtures that have been tested or evaluated for their performance.

Faucets: Water flow is reduced by aeration or laminar flow:

- » Aeration injects air into the stream of water, displacing much of the water content.
- » Laminar flow uses multiple small diameter parallel streams of water that are not aerated.



Faucets with laminar flow restrict water use.



A note on durability: In buildings where restrooms in common areas and bathrooms in private units are likely to see high use or even abuse, wall-hung sinks may pull away from the walls because people sit or even stand on them. Provide extra bracing for wall-hung sinks or use reinforced vanities.

Showerheads: Flow rate is typically reduced by flow restriction or aeration:

- » Cheaper showerheads usually restrict the water flow.
- » Aeration with multiple flow settings provides better performance.

Toilets: Today's standard 1.6-gpf toilets are called *Ultra-Low Flow Toilets (ULFT)*. Toilets are available that use less than 1.6 gpf; these are called *High Efficiency Toilets (HET)*. HET products include:

- » Pressure-assist models that use compressed air to aid flush performance.
- » Models with dual-flush mechanisms. Users can choose between a 0.8 to 1.0-gallon flush for urine and a 1.6-gallon flush for solids. In actual operation, dual-flush models average about 1.2 to 1.4 gpf.

To ensure that the toilets continue to operate as intended over time, select models that will perform well with replacement parts available at local hardware or supply stores. If special-order parts are required, consider stocking those on site for ready access.

Code Considerations

There are no code issues with HETs or high-performance showerheads and faucets. Code issues *will* arise for projects considering the use of waterless urinals and composting toilets.

Considerations for Residents

- » Selecting fixtures that perform well so as not to reinforce occupants' perceptions that low-flow fixtures work poorly (*for product information, see Resources section*).
- » Minor maintenance will keep faucet aerators from becoming clogged—unscrew the aerator, clean it and screw it back on.

- » Only use original equipment manufacturer (OEM) products when repairing toilets so as not to compromise performance (*see sidebar*).
- » Low-flow showerheads help provide warmer showers. The reduced water delivery rate allows the water heater to maintain a more constant temperature.

Cost and Cost Effectiveness

| | | |
|---------|--------|---|
| BENEFIT | ★★★ | High Efficiency Toilets and low-flow showerheads and faucets are cost effective and pay for themselves within one year in most cases. |
| COST | \$\$\$ | |

Some laminar faucets will cost more than aerator units.

Resources

- » **EBMUD** publishes a list of commonly available, approved toilets for use in their toilet replacement rebate program. The toilets are rated based on performance, and vendor information is provided. They also offer free low-flow showerheads and faucet aerators through their Conservation department. Tel. (510) 287-0590
www.ebmud.com/conserving_&_recycling/residential
- » **Environmental Building News** has information about waterless urinals; see in particular Vol. 11, No. 2, Feb. 2002:
www.buildinggreen.com/products/falcon.html

DID YOU KNOW...

Recent testing by the East Bay Municipal Utility District and the City of Seattle found that out-of-box new toilet performance ranged from 1.45 to 1.89 gpf.

The study found that fitting the same toilets with generic replacement flappers reduced performance to an average of 2.9 gpf—with a high of 4.7 gpf!

Source: EBMUD and City of Seattle Toilet Performance Testing Report, 2002.

FINISHES & FURNISHINGS

Creating a multifamily green building doesn't end with the design of the structure and systems. The finishes and furnishings that help transform a building shell into a home play an important—and often highly visible—role in determining how green and healthy that home will be.

Certain conventional finishes and furnishings may undermine a project's green goals. For example, cabinets made with particleboard containing urea-formaldehyde binders may continue to release formaldehyde, a probable carcinogen, into a home for years after installation. Using environmentally preferable finishes and furnishings can help ensure that a building is durable, resource efficient, and healthy for workers and residents.

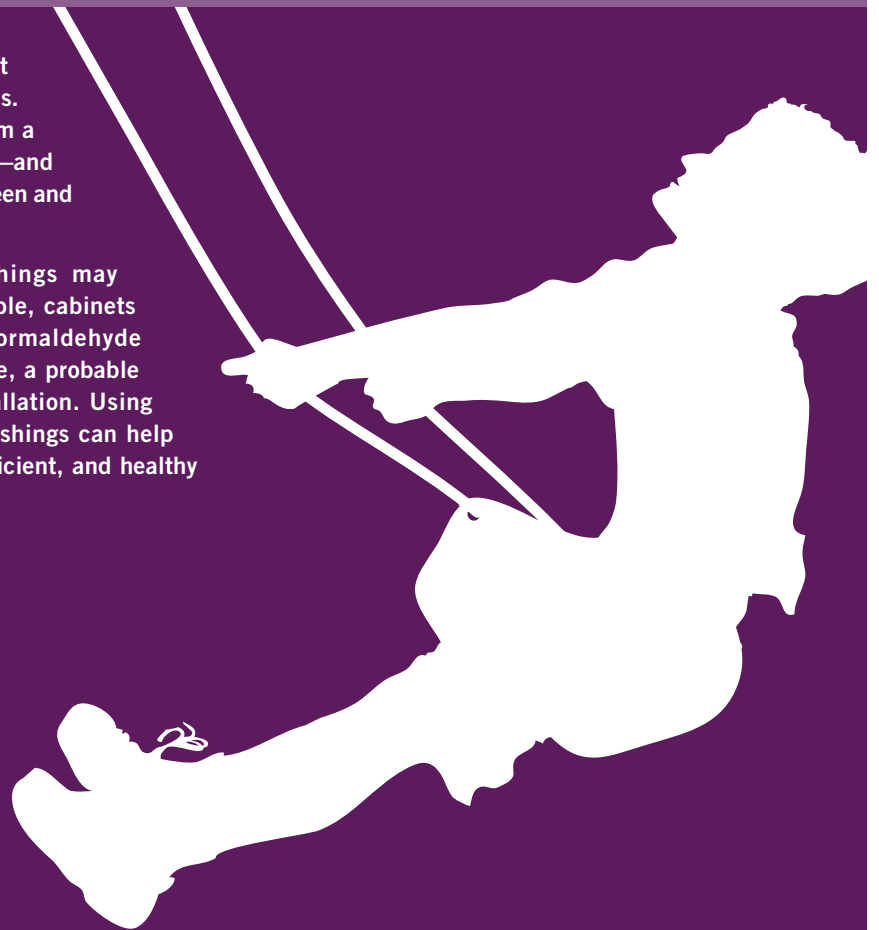

BENEFITS

This table lists the Guidelines' finishes and furnishings measures, and shows the primary benefits of each (see the individual measures for details).

| MEASURE | BENEFITS | | | | | | | |
|--|------------|---|-------------------|------------------|---|-----|-----------------------|--------------|
| | Health/IEQ | Site/Community | Energy Efficiency | Water Efficiency | Material Efficiency | O&M | Resident Satisfaction | ENERGY STAR® |
| 01 Entryways | ✓ | | | | | ✓ | ✓ | |
| 02 Interior paint | ✓ | ✓ | | | | ✓ | ✓ | |
| 03 Adhesives and sealants | ✓ | ✓ | | | | ✓ | ✓ | |
| 04 Metal coatings | ✓ | ✓ | | | ✓ | ✓ | ✓ | |
| 05 Carpeting | ✓ | | | | ✓ | ✓ | ✓ | |
| 06 Natural linoleum | ✓ | | | | ✓ | ✓ | ✓ | |
| 07 Wood flooring alternatives | | | | | ✓ | ✓ | ✓ | |
| 08 Reclaimed materials | | | | | ✓ | | | |
| 09 Cabinets, counters & trim | ✓ | | | | ✓ | ✓ | ✓ | |
| 10 Furniture & outdoor play structures | ✓ | | | | ✓ | ✓ | ✓ | |
| EXPLANATION OF BENEFITS | | <p>Health/IEQ: Reduces indoor pollutants, promotes better indoor environmental quality, and/or provides opportunities for improved public health.</p> <p>Site/Community: Protects land, water and air on and near site from pollution or other environmental damage, uses municipal infrastructure more efficiently by redeveloping building or site, and/or provides important and needed amenities for the surrounding community.</p> <p>Energy Efficiency: Reduces building energy consumption.</p> <p>Water Efficiency: Reduces water use in building and/or on site.</p> | | | <p>Material Efficiency: Reduces, reuses and/or recycles materials that might have otherwise ended up in landfills, reduces materials needed to construct or operate the building, and/or uses materials produced in a way that minimizes environmental damage.</p> <p>O&M: Increases building's durability, and/or reduces operating and maintenance expenses.</p> <p>Resident Satisfaction: Saves residents money and/or improves residents' quality of life.</p> <p>ENERGY STAR®: Helps achieve ENERGY STAR® for Homes certification.</p> | | | |

KEY CONSIDERATIONS

DESIGN PROCESS

Ideally, green finishes and furnishings should be specified early, as part of an integrated design process (see the introduction to these Guidelines). It is possible, however, to make incremental improvements to a conventional building that is already underway by including some of the green finishes and furnishings measures described in these Guidelines. For example, if the original design calls for vinyl flooring, it may be possible to substitute natural linoleum (*Finishes & Furnishings: Measure 06*) if there is funding for the added cost. Low-VOC paints (*Finishes & Furnishings: Measure 02*) can readily be substituted for conventional VOC-compliant paints, although the cost may be slightly higher and allowances may need to be made for differences in paint coverage and drying time.

AVAILABILITY

Green and healthy finishes are now much more readily available than even a few years ago. All major paint manufacturers, for example, make low- or zero-VOC paints that meet performance requirements. There are many suppliers of linoleum (*Finishes & Furnishings: Measure 06*) and recycled-content carpet (*Finishes & Furnishings: Measure 05*). Other products, while generally available, may require more effort to obtain, such as cabinetry with no added formaldehyde (*Finishes & Furnishings: Measure 09*).

COST

It is critical that operations and maintenance costs be taken into account when considering the costs of finishes and furnishings. Some conventional products cost less initially than environmentally preferable options, but are inferior in quality and will require frequent and costly maintenance, repair or replacement.

Many green finishes and furnishings are cost-competitive with conventional products and can be used in virtually any affordable multifamily housing project. These include low-VOC paints (*Finishes & Furnishings: Measure 02*), HCFC-free sealants (*Finishes & Furnishings: Measure 03*), recycled-content carpet (*Finishes & Furnishings: Measure 05*), factory-applied metal coatings (*Finishes & Furnishings: Measure 04*) and entryways designed to reduce tracked-in pollutants (*Finishes & Furnishings: Measure 01*).

Certain materials, such as recycled ceramic tile (*Planning & Design: Measure 14*) and bamboo flooring (*Finishes & Furnishings: Measure 07*), may tend to cost more than conventional products, requiring a special commitment from the developer. But some of these more expensive green products may provide a marketing advantage—attractive green materials have a certain cachet among environmentally aware renters, homebuyers, and perhaps even funders.

INSTALLATION AND SCHEDULING

On any jobsite, whether it's a green or conventional project, it is important to follow safe and healthy practices such as providing proper ventilation when applying paint, adhesives and sealants, which typically offgas the most when they are wet and being applied. Going beyond basic practices and carrying out an IAQ management plan (*Sitework: Measure 03*) for construction and preoccupancy phases is strongly recommended. This may affect scheduling. For example, flushing out interior spaces may require extra time in the construction schedule.



Daylighting coupled with low-VOC finishes and furnishings combine to create enjoyable spaces like these common rooms at El Paseo Studios.

ROLES AND RESPONSIBILITIES

PRODUCT SUBSTITUTIONS

Be sure the entire design and construction team understands the project's green building goals and requirements so that design intentions aren't compromised by product substitutions. To someone not familiar with the principles of green building, one brand of carpet, for example, may seem as good as another, but the specified product may have characteristics such as superior durability, recycled content or low emissions. In bidding and construction documents, clearly spell out product specifications, and, where appropriate, provide product brand names and even contact information for local suppliers.

MAINTENANCE

To ensure that finishes and furnishings continue to provide health, durability and environmental benefits, they need to be properly maintained, using effective but low-toxic cleaning products and maintenance techniques. Teach staff and residents about appropriate maintenance procedures, and give residents some guidance on where to find and how to choose green, healthy furnishings (*see the Operations & Maintenance section*).

- » **Developer and project manager.** For projects designed as green from the start, make a commitment to providing adequate funding for desirable green finishes and furnishings that may have higher upfront costs but provide long-term benefits and savings. Recognize that individual green building upgrades will vary in cost; some cost more, others less. Remember that individual green building measures add up to more than the sum of their parts. For projects not designated as green from the start, look for opportunities to make incremental improvements by incorporating some green finishes and furnishings.
- » **Architect and interior designer.** Stay current on the performance, cost, availability and other pertinent characteristics of green finishes and furnishings. With every product spec, question whether there is another product that would be healthier, more resource efficient, more durable or provide other green benefits.
- » **Builder.** Support the project's green-building goals. Work with subs to ensure their support, be vigilant about unauthorized substitutions of products or procedures, and ensure that all sustainable jobsite procedures are followed.
- » **Building manager.** Educate staff and residents on proper maintenance. Examine customary building management processes and look for changes that might contribute to a healthier, greener facility.

FOCUS ON FINISHES: Betty Ann Gardens

In the Betty Ann Gardens Family Apartments in San Jose, low-VOC interior paints and varnishes were used throughout the project, helping to protect indoor air quality. All carpet contains recycled materials, minimizing the use of virgin plastics. Carpet tiles, rather than rolls, were used so that worn or damaged tiles can be selectively replaced rather than replacing large sections of carpet. Natural linoleum, a durable material made from renewable resources, was used for kitchen and bathroom flooring.

To learn more about this project, see the Betty Ann Gardens case study.

ENTRYWAYS

Design Entryway to Reduce Tracked-In Contaminants

| WHO | KEY BENEFITS |
|---|---|
| <ul style="list-style-type: none"> ✓ Developer/PM Funder Policymaker ✓ Architect ✓ Builder Resident ✓ Building Manager | <ul style="list-style-type: none"> ✓ Health/IEQ Site/Community Energy Efficiency Water Efficiency Material Efficiency ✓ O&M ✓ Resident Satisfaction ENERGY STAR® |
| 12485: Entryway Track-off Systems | |

Recommendation

Minimize the amount of contaminants tracked inside by installing walk-off systems at the entryway of buildings and units.

Where possible, specify easily cleaned flooring with a hard surface for the building's entryways and the units' doorways.

Description

One way to improve indoor air quality (IAQ) is to use materials and finishes with low toxicity, including low or zero levels of formaldehyde and volatile organic compounds (VOCs). Another way is to reduce the amount of dust and particulates entering the building from foot traffic.

Up to two-thirds of dust in houses is tracked in from shoes of occupants. The dust contains everything from soil and pesticides to abrasive sand, mold and bacteria. Once these particulates are inside the building, they can be difficult to get rid of, especially from surfaces such as carpet that readily traps and absorbs large amounts of particulates. Carpeting also provides an environment where organisms such as mites and mold can thrive.

Benefits

Proper entryway design reduces the amount of dust and toxins tracked into the building.

In common-area entryways that are maintained by a janitorial staff, good entryway design can reduce cleaning costs and prolong the life of flooring materials.

Application

All multifamily buildings can be designed for entryway pollutant control.

Design Details

In multifamily buildings, there are two opportunities to positively affect IAQ through entryway design: the common entry areas, such as lobbies, hallways, balconies, laundry rooms, community rooms and elevator areas; and the living units themselves. The IAQ and health implications are greatest in the living units, especially those occupied by children and elderly residents.

Here are strategies for good entryway design:

COMMON ENTRANCES

- » Specify a three-component track-off entryway system that consists of:
 1. A permeable outdoor mat or grille system to collect the dirt and water;
 2. Indoor mats that aid in scrubbing shoes; and
 3. A smooth-surface, waterproof flooring material that is easily cleaned and will collect any remaining contaminants from footprints (such as tile, stained concrete or laminate products).

These systems should extend 30 feet into the building at entryways or as close to that length as possible.

- » Avoid carpet at entryways because it is hard to clean and it traps dirt.
- » Avoid using pesticides and other chemicals near buildings (*Planning & Design: Measure 08—Landscaping*).
- » Vacuum, rinse and clean entryway areas regularly.
- » Glazed tiles or other flooring may become slippery when wet. Use anti-slip products or methods where this is a concern.
- » Pave walkways leading to entries and discourage foot traffic through landscaped areas.
- » Directly inside entryways, specify durable wall finishes that are easy to clean or touch up. Semi-gloss paint coupled with wainscoting, chair rails, baseboards and corner guards will reduce everyday wear-and-tear.

DWELLING UNITS

- » Avoid adhered carpeting at entryways.
- » Provide areas near entryways for removal of wet outerwear and shoes. This may take the form of a tiled surface or mudroom.
- » Address proper cleaning practices in the residents' manual (*Operations & Maintenance: Measure 01—Training and Manuals*).

Finally, where possible, choose recycled-content track-off products. A number of vendors now use recycled rubber and other natural materials for track-off products and doormats (*Planning & Design: Measure 14—Recycled Products*).



Permanent entryway grilles like this one help reduce tracked-in contaminants at central entrances.

Code Considerations

Work with local jurisdictions to design entryways that are accessible to all residents, and take into consideration potential changes in tenant types in the future (*Planning & Design: Measure 15—Design for Adaptability*). Carefully design ramps and stair assemblies so that they meet accessibility requirements while also allowing for track-off systems.

Considerations for Residents

Occupants will benefit by having cleaner entrances and fewer contaminants inside their homes.

Cost and Cost Effectiveness

| | | |
|----------------|--------|--|
| BENEFIT | ★★★ | Techniques for managing entryway contamination can be as simple as floor mats. Other strategies, including tile or hard surfaces for entryways, can cost more than carpeting, but have the potential to last much longer. A three-step grille system with mats and easy cleaning access will add some expense, and are often special-order items requiring additional design time. |
| COST | \$\$\$ | |

Proper entryway design, however, is far less expensive than some other IAQ practices or materials, with the potential for much greater success.

Resources

- » *Environmental Building News* article, “Keeping Pollutants Out: Entryway Design for Green Buildings,” Vol. 10, No. 10:
www.buildinggreen.com
- » **American Lung Association HealthHouse** has guidelines for ensuring good IAQ:
www.healthhouse.org

INTERIOR PAINT

Specify Low- and Zero-VOC Interior Paint

| WHO | KEY BENEFITS |
|---|--|
| <ul style="list-style-type: none"> ✓ Developer/PM Funder Policymaker ✓ Architect ✓ Builder Resident ✓ Building Manager | <ul style="list-style-type: none"> ✓ Health/IEQ ✓ Site/Community Energy Efficiency Water Efficiency Material Efficiency ✓ O&M ✓ Resident Satisfaction ENERGY STAR® |
| 09912: Interior Paint | |

Recommendation

Specify low- or zero-VOC paint for interior primer, flat, semi-gloss and high-gloss applications.

Give preference to water-based stains and finish coat sealants wherever possible.

Description

The strong smell that paint normally emits is from the evaporation of volatile organic compounds (VOCs). Most of this offgassing occurs during and in the first few days after painting, but the health and comfort impacts on painters and occupants can be substantial during that period.

VOC ratings are generally reported for the base paint before the product is tinted. Most tints are synthetic and add some VOCs, although a few brands have true zero-VOC tints. Because of the VOCs in tints, saturated colors usually have higher levels of volatiles than light colors. Some manufacturers only offer low-VOC paints in the light and moderate tints.

Low-VOC interior paints should have the following VOC limits before colorants are added to bases (based on Green Seal's requirements for VOCs):

Non-flat: 150 grams/liter (g/l)

Flat: 50 g/l

Most paint companies now carry products that meet these VOC limits.

Many paints include preservatives that may contain formaldehyde and other harmful compounds. Fortunately, low- and zero-VOC paints have reduced levels of these materials, but some still do use them in their products.

Healthy paint formulas have been substantially improved over the past few years, so concerns about performance and cost of the first generation of low- and zero-VOC paints have largely been addressed. All the large manufacturers have proven products, including Benjamin Moore *Pristine Ecospec*, Kelly Moore *Enviro-Cote*, Pittsburgh Paints *Pure Performance*, AFM *Safecoat*, ICI/ Glidden *LifeMaster 2000* and Sherwin Williams *Harmony*.

A variety of water-based stains and finish sealers are now available that perform as well as oil-based products, but with much lower VOC levels.

Benefits

Low- and zero-VOC paints provide numerous benefits over standard "VOC compliant" paints (*for more about the "VOC compliant" label, see Code Considerations section*). Benefits include:

Improved indoor air quality for workers and occupants, helping alleviate asthma, headaches, and lung and eye irritation.

- » All low/zero-VOC paints are water-based, so cleanup doesn't require paint thinner, reducing toxic waste at the jobsite.
- » Reducing VOCs helps reduce ground-level ozone formation, more commonly known as smog. Smog, according to the U.S. EPA, contributes to lung damage, skin cancer and reduced resistance to infection in humans, as well as crop and forest damage and other problems. Using low-VOC products can help reduce these risks.
- » Low-VOC paints typically have lower levels of toxic biocides (preservatives), including formaldehyde.
- » Leftover latex paint can be recycled back into paint. Oil-based paints and solvents are typically "downcycled" (that is, turned into a product with less value than paint) or are incinerated to produce power.

Application

Applicable to all interior painted surfaces except metals, plastics and special high-abuse areas such as over sinks in bathrooms and kitchens. High abuse areas may require specially formulated latex or oil-based/alkyd paints for their stain-covering and durability properties.

To improve durability and make cleaning easier in heavily used spaces such as corridors, restrooms and laundry facilities, use a semi-gloss or highly reflective paint.

When renovating or repainting an older building, test for lead in earlier coats of paint. If lead paint is present, use appropriate disposal and abatement methods.

Design Details

Proper paint application should be a part of good indoor air quality (IAQ) construction practices. First, minimize potential IAQ concerns from painted surfaces by specifying that materials be finished offsite whenever possible. Second, allow sufficient ventilation and airing out of the areas during and after painting to reduce exposure to any remaining VOCs (*Sitework: Measure 03—Construction IAQ Management / Finishes & Furnishings: Measure 04—Metal Coatings*).

Some low- and zero-VOC paints perform differently than paints with volatile additives—for example, spread, cover and drying time may differ—so it is important to check the performance with an experienced painter ahead of time.



Keep in mind that many professional painting contractors and suppliers may have a negative view of low-VOC paints due to problems with first-generation products. Make sure they have tried the latest products, as low/zero-VOC paints have been reformulated to improve performance.

Code Considerations

VOC limits are regulated by the U.S. EPA nationally and the State of California locally. Most paints have language such as “Low-VOC Compliant” or “VOC Compliant.” This merely refers to California’s VOC limits. It does not mean the product meets this Guidelines’ recommended VOC levels—it simply means the product is legal for sale in the State of California.

Considerations for Residents

People with chemical sensitivities can have adverse reactions to paint. Low- or zero-VOC paint may or may not help this.

Educate occupants and building maintenance staff about the benefits of low/zero-VOC paint and encourage them to continue using these products (*Operations & Maintenance: Measure 01—Training and Manuals*).

Cost and Cost Effectiveness

| | | |
|---------|--------|--|
| BENEFIT | ★★★ | Some zero-VOC paints are considered premium grade by manufacturers and cost the same as standard premium-grade paints. However, more contractor-grade product lines are becoming available in low/zero-VOC varieties; these are priced lower than premium paints. The incremental retail price of most low- and zero- VOC paints ranges from \$0 to \$4 per gallon, depending on brand, quantity and product line differences. |
| COST | \$\$\$ | |

Coverage, spreadability and drying time may affect product or labor costs. Some low-VOC products take longer to dry and may not cover or spread as well as standard paints. Check with professional installers on these issues.

Resources

Green Seal verifies VOC levels and rates products that do not contain harmful solvents, formaldehyde and specific heavy metals: www.greenseal.org.

- » **Scientific Certification Systems (SCS)** verifies VOC-free product claims: <http://scs1.com>
- » **Green Resource Center’s** “greener paints” fact sheet: www.greenresourcecenter.org
- » **Environmental Building News** has a comprehensive review of paint and VOC issues in Vol. 8, No. 2: www.buildinggreen.com
- » **California Department of Health Services’** Specification Section 01350 outlines emissions standards: www.ciwmb.ca.gov/GreenBuilding
- » **California Integrated Waste Management Board** has a publication on recycled latex paint: www.ciwmb.ca.gov/publications/buyrecycled/43197034.doc
- » **Housing and Urban Development** has a section of its website dedicated to lead paint safety: www.hud.gov/offices/lead. For HUD’s Lead Paint Safety guide, go to: www.hud.gov/offices/lead/training/LBPguide.pdf
- » **ACWMA’s** Materials Database lists products that correspond with this measure: www.multifamilygreen.org

ADHESIVES AND SEALANTS

Specify Solvent-Free (Low- and Zero-VOC) Adhesives and HCFC-Free Foam Sealants

| WHO | KEY BENEFITS |
|---|--|
| <ul style="list-style-type: none"> ✓ Developer/PM Funder Policymaker ✓ Architect ✓ Builder Resident ✓ Building Manager | <ul style="list-style-type: none"> ✓ Health/IEQ ✓ Site/Community Energy Efficiency Water Efficiency Material Efficiency ✓ O&M ✓ Resident Satisfaction ENERGY STAR® |

07922: Caulk Joint Sealants, **07924:** Foam Joint Sealants
09601: Flooring Adhesives

Recommendation

Specify low- and zero-VOC construction adhesives and adhesive caulks that do not contain solvents.

Specify foam sealants that do not contain HCFCs.

Description

ADHESIVES

Many conventional construction adhesives and adhesive caulks are solvent-based and release significant amounts of volatile organic compounds (VOCs). Low- and zero-VOC, low-toxic and water-based products are now available from many manufacturers to replace solvent-based products *(for more information about low- and zero-VOC products and other indoor air quality issues, see Sitework: Measure 03—Construction IAQ Management / Sitework: Measure 04—Hazardous Materials and Waste / Finishes & Furnishings: Measure 02—Interior Paint)*.

- » **Polyurethane and acrylic/latex adhesives** are noncombustible, very low in VOCs and have low odor. They provide good bonding strength with spread and cover comparable to normal construction adhesives. Most also cure at the same rate as their more toxic counterparts.
- » **Flooring adhesives** are also available in low- and zero-VOC versions.

FOAM SEALANTS

Foam sealants are used to seal penetrations in the building envelope. Select products that do not contain hydrochlorofluorocarbons (HCFCs) as the foam's blowing agent. HCFCs contribute to the depletion of the ozone layer and to global warming *(for more information, see Systems: Measure 08—High-Efficiency Air Conditioning with Advanced Refrigerant)*.

Benefits

Low- and zero-VOC construction adhesives eliminate the need for highly volatile cleanup products such as paint thinner. Low- and zero-VOC products improve air quality for construction workers and occupants.

HCFC-free foam sealants are environmentally preferable because they contribute less to ozone depletion and global warming than HCFC-based foams.

Application

Polyurethane construction adhesives can be used on foam, wood, metal, fiberglass and most common building materials under most weather conditions. Low- and zero-VOC adhesives are also available for carpeting, natural linoleum, tile and other building products.

Foam sealants can be used to seal penetrations in the building envelope *(for more on sealing penetrations, see Systems: Measure 10—Advanced Ventilation Practices)*.

Design Details

To make implementation easier, include within the specifications the specific brand names of low-VOC products and locations of product retailers.

On construction walk-throughs, routinely check discarded sealant and adhesives containers and verify they are solvent-free.



Many contractors are accustomed to using adhesives and sealants with high VOCs. Early discussion, training and product testing can alleviate contractors' concerns and ensure that the specified products are used.

Code Considerations

Low-VOC adhesives and sealants meet and exceed California code requirements for reduced VOCs. The Bay Area Air Quality Management District sets standards for VOC emissions from products. These guidelines are stringent, but many products have far lower VOC levels than is required by code. Specify the lowest VOC levels possible by selecting water-based products and/or eliminating solvents wherever possible.

Considerations for Residents

Low- and zero-VOC products help improve indoor air quality. This is a particular issue for flooring adhesives that may offgas into the living space for a long time

(*Finishes & Furnishings: Measure 05—Carpeting / Finishes & Furnishings: Measure 06—Natural Linoleum*).

Cost and Cost Effectiveness

| | | |
|---------|---------|---|
| BENEFIT | ★★★ | Low- and zero-VOC adhesives and sealants do not cost more than solvent-based products. Some adhesives may be more difficult to locate at retail outlets, though most are available through normal contractor suppliers. |
| COST | \$ \$\$ | |

Foam sealants that do not use HCFCs are available at retail outlets and contractor suppliers, and are competitive in price with standard products.

Resources

- » **BuildingGreen**, publisher of *Environmental Building News*, has information about environmentally preferable adhesives and sealants, including product lists and reviews:
www.buildinggreen.com
- » **Green Seal** is a third-party labeling agency that has VOC guidelines for commercial construction adhesives:
www.greenseal.org
- » **LEED Reference Guide version 2.1** has language on VOC requirements for adhesives and sealants:
www.usgbc.org
- » **Bay Area Air Quality Management District** sets rules for VOC limits of adhesives and sealants. Download Rule 51 at:
www.baaqmd.gov/dst/regs/rg0851.pdf
- » **ACWMA's** Materials Database lists products that correspond with this measure:
www.multifamilygreen.org

METAL COATINGS

Specify Factory-Applied Finishes on Metal and Other Products

| WHO | KEY BENEFITS |
|--|--|
| <ul style="list-style-type: none"> ✓ Developer/PM Funder Policymaker ✓ Architect ✓ Builder Resident Building Manager | <ul style="list-style-type: none"> ✓ Health/IEQ ✓ Site/Community Energy Efficiency Water Efficiency ✓ Material Efficiency ✓ O&M ✓ Resident Satisfaction ENERGY STAR® |

DIVISION 5: Metals, 09970: Metal Coatings

Recommendation

Reduce the amount of site-applied finishes to metal and other products by specifying factory-applied finishes where applicable.

Description

Most metal coatings, including primers and paints, are oil-based products with high solvent levels. It is possible to avoid using most of these products on site by specifying factory-finished materials and by designing to accommodate variable field conditions so that most field cutting and welding isn't necessary. Eliminating metal coatings from the construction site reduces waste and makes cleanup, handling and waste disposal easier.

(For more information about indoor air quality issues related to interior finish products, see Finishes & Furnishings: Measure 02—Interior Paint; Measure 03—Adhesives and Sealants; and Measure 09—Cabinets, Counters and Trim)

POWDER COATING

A design that accommodates factory-finished metals can often make use of powder coating. For this treatment, dry powder is applied to metal (or wood) via a spray gun. The powder particles adhere to the surface and are held in place with an electric charge until they are fused in a curing oven. The result is a uniform, durable and high-quality finish that is solvent-free and has low emissions. Powder-coat overspray can be readily retrieved and reused.

Benefits

Metal products finished at factories (preferably in California because of the state's strict emissions and waste handling regulations) reduce the exposure of jobsite workers and occupants to chemicals.

Cleanup of many paints and other products results in hazardous waste; finishing materials offsite makes it easier for the hazardous waste to be dealt with in compliance with environmental laws. Factory finishing also minimizes site contamination and potential liability from spills and illegal dumping (*Sitework: Measure 04—Hazardous Materials and Waste*).

Application

Railings, bike racks, overhangs, trellises, handrails and other metal products can be finished at the factory. Other products, such as shelving, flooring and some outdoor furnishings can also be ordered with a powder coating or finished offsite.



Factory-applied coatings on metal railings reduce onsite exposure to toxic materials and limit hazardous waste.

Design Details

One reason metal is finished on site is because metal products often need to be cut and welded during installation. During construction, products don't always fit as designed. This can present a problem with prefinished metal because it must be recoated once it is cut and welded.

If designers are aware of this potential problem, they can allow for these tolerances by leaving some extra room. Some cutting and welding may still be necessary, however, and the metals should be recoated to preserve them. If metal must be finished on site, consider using an acrylic-based product.

Always ask for matching touch-up paint from manufacturers.

Code Considerations

None.

Considerations for Residents

Factory finishes result in less exposure to VOCs for construction workers and occupants.

Cost and Cost Effectiveness

| | | |
|----------------|--------|--|
| BENEFIT | ★★★ | Powder-coated products are cost competitive with finishes installed on site. Additionally, cleanup and hazardous waste disposal costs are reduced. |
| COST | \$\$\$ | |

Resources

- » **Powder coating industry's** informational website: www.powdercoat.com
- » **Building Green's *GreenSpec Directory*** has listings of alternative metal primer materials. www.buildinggreen.com

CARPETING

Select Natural, Recycled-Content and Low-VOC Carpet

| WHO | KEY BENEFITS |
|---|--|
| <ul style="list-style-type: none"> ✓ Developer/PM Funder Policymaker ✓ Architect Builder Resident ✓ Building Manager | <ul style="list-style-type: none"> ✓ Health/IEQ Site/Community Energy Efficiency Water Efficiency ✓ Material Efficiency ✓ O&M ✓ Resident Satisfaction ENERGY STAR® |
| 09680: Carpet | |

Recommendation

In common areas, select commercial-grade carpet with recycled content and low VOC emissions. Specify products that pass the emission tests in the State of California's Special Environmental Requirements Specification—Section 01350.

In residential units, select natural fiber carpet or recycled-content synthetic fiber carpet. If a carpet underlay is needed, specify a high recycled-content product with low VOC emissions.

Description

Carpet, and flooring in general, is an area of intense scrutiny for waste reduction efforts because so much is used, it is frequently replaced, and it is difficult and expensive to recycle. One method to minimize the environmental consequences of carpeting is to limit its use: don't use wall-to-wall carpeting if you don't need to. To further reduce waste and improve indoor air quality (IAQ), use a durable carpet with a high recycled content and low levels of volatile organic compounds (VOCs), and use a low-VOC adhesive.

CARPETS AND VOCS

The State of California's Special Environmental Requirements Specification—Section 01350 contains specification language on environmental and public health considerations for sustainable building projects. Section 01350 was developed by the California Integrated

Waste Management Board (CIWMB), Department of Health Services and other state agencies and experts. The specification covers many aspects of green building, including energy, materials and water efficiency, and IAQ.

Section 01350 includes product selection guidelines, as well as testing protocols that require manufacturers to have their products tested by independent laboratories for compliance with specific emissions levels. CIWMB maintains a database of products that have passed the test (*see Resources section*).

CARPET CUSHION

Depending on the kind of carpet used, carpet cushion (or underlay) may be needed. Carpet cushion can improve carpet's insulation properties, reduce wear from foot traffic and furniture, and prolong appearance. It is available in a variety of thicknesses, the most common being ¼- and ½-inch. Carpet cushions, made from bonded urethane, jute, synthetic fiber and rubber, are available with high percentages of recycled materials. The Carpet and Rug Institute (CRI) labels low-VOC carpet cushions with the Green Label. CRI also labels carpets, but their testing protocols are not as stringent as Section 01350.

CLOSING THE LOOP

Recycling carpet at the end of its useful life is important. Many carpet manufacturers are implementing programs for pickup, reuse or recycling of old carpet. Some manufacturers also offer carpet leasing as a way to promote recycling and possible reuse. Check with vendors for such take-back programs.

Benefits

Purchasing recycled carpet helps promote markets for recycled products. Recycled-content carpet made from soda bottles (PET plastic) offers vibrant colors and high stain resistance thanks to the plastic's natural stain-deterring properties. Recycled nylon carpet, more common in commercial-grade products, performs the same as nonrecycled products. Some nylons can be processed back into carpet fiber, while others are ground up and used for backing materials.

Natural fiber carpets are made from renewable resources that are replenished in less than ten years.

Low-VOC carpeting, cushion and adhesives improve indoor air quality by reducing offgassing.

Application

High recycled-content, low-emission carpet can be used everywhere standard carpet is used. Areas with high traffic, such as entrances, lobbies and community areas, can benefit from resilient commercial-grade sheet or tile carpeting. If the budget allows, use durable commercial carpet for the residences as well (*for information about flooring for entryways, see Finishes & Furnishings: Measure 01—Entryways*).

Design Details

COMMON AREAS

Instead of using wall-to-wall carpeting, consider reducing the amount of carpet used by covering less of the floor's surface area. Stained or colored concrete and other thermal mass floors (*Systems: Measure 02*) or natural linoleum (*Finishes & Furnishings: Measure 06*) can accompany the carpeted areas as attractive design features.

Consider using commercial-grade carpet, which is much more durable than residential carpet. Carpets are available with 100% recycled backing, and some also have recycled-content face fiber. Consider the carpet's color and its effect on maintenance; light-colored carpet tends to show dirt more readily than darker colors. Select solution-dyed carpets rather than carpets dyed using other methods; solution-dyed carpets are more colorfast and hold up better to heavy-duty cleaning. Carpet tiles are also a good option thanks to improvements in the bonding technology.

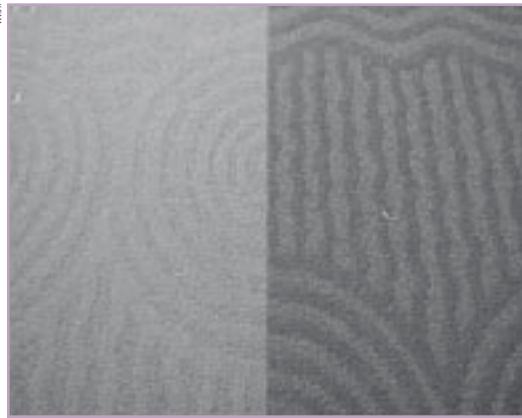

These carpet tiles contain recycled content and have low-VOC emissions. Carpet tiles reduce waste because worn sections can be selectively replaced.

RESIDENTIAL UNITS

Use recycled-content carpet, which is typically made from discarded plastic bottles. Some manufacturers also offer recycled nylon, wool and cotton carpets. Natural flooring materials made from wool or plant fibers such as jute, seagrass, sisal, linen and coir are available, but may be more expensive or less durable than synthetic carpets; if used, residents should be made aware of specific maintenance techniques. The main advantage of natural fibers is that they come from biodegradable, rapidly renewable resources.

INSTALLATION AND MAINTENANCE

Recycled nylon and plastic carpets have the same installation and maintenance requirements as nonrecycled carpets. If carpeting is to be glued down, use a low- or no-VOC adhesive; many manufacturers now make products that perform well. Some carpet tile

manufacturers utilize a low-toxic glue that is factory-applied, thus reducing VOC emissions on site (*Finishes & Furnishings: Measure 03—Adhesives and Sealants*).

Vacuum carpets regularly to ensure good indoor air quality. For daily maintenance, use vacuums with HEPA filters.

Code Considerations

None.

Considerations for Residents

Low-VOC carpets and adhesives can improve indoor air quality over standard products that do not meet the specification 01350 emissions tests. Carpet cushions labeled with the CRI label will tend to reduce VOC emissions during the first weeks and months after installation.

Cost and Cost Effectiveness

| | | |
|---------|--------|--|
| BENEFIT | ★★★ | In general, there is little to no premium for buying high recycled-content carpet. |
| COST | \$\$\$ | |

Using more durable commercial carpet reduces replacement costs. Warranties on commercial products can be twice that of residential carpet warranties. Carpet tiles may save money because damaged tiles can be selectively replaced, but this requires stocking spare tiles in case the product line is discontinued.

Resources

- » **Carpet America Recovery Effort (CARE)**, a voluntary industry/government initiative, seeks to keep carpets out of landfills: www.carpetrecovery.org
- » **California Integrated Waste Management Board's Section 01350**: www.ciwmb.ca.gov/greenbuilding/Specs/Section01350
Products that passed the emissions tests: www.ciwmb.ca.gov/greenbuilding/Specs/EastEnd/default.htm
- » **U.S. EPA's Comprehensive Procurement Guidelines** have information on recycled-content carpet and underlay: www.epa.gov/cpg
- » **Environmental Building News** (Vol. 3, No. 6) has an article about sheet carpeting: www.buildinggreen.com
- » **Carpet and Rug Institute (CRI)** sponsors the Green Label for certified carpet pads: www.carpet-rug.com
- » **ACWMA's Materials Database** lists products that correspond with this measure: www.multifamilygreen.org

NATURAL LINOLEUM

Use Natural Linoleum for Resilient Flooring

| WHO | KEY BENEFITS |
|---|--|
| <ul style="list-style-type: none"> ✓ Developer/PM ✓ Funder ✓ Policymaker ✓ Architect ✓ Builder ✓ Resident ✓ Building Manager | <ul style="list-style-type: none"> ✓ Health/IEQ ✓ Site/Community ✓ Energy Efficiency ✓ Water Efficiency ✓ Material Efficiency ✓ O&M ✓ Resident Satisfaction ENERGY STAR® |
| 09580: Resilient Flooring | |

Recommendation

Specify natural linoleum for resilient flooring.

Description

Natural linoleum is a durable product that was once the standard resilient flooring in the United States, but has been largely displaced by cheaper vinyl flooring. Vinyl flooring is often called “linoleum,” but it is not the same material. In recent years, real linoleum has been making a comeback because of its environmental, health and performance advantages over vinyl.

Linoleum is made from rapidly renewable materials, including linseed oil (from flax), powdered wood and/or cork, ground limestone, resin binders and dry pigments, with a natural jute fiber backing. The linoleum manufacturing process uses relatively little energy and very few chlorine- or petroleum-based resources.

Polyvinyl chloride (also called PVC or vinyl), on the other hand, is made from petroleum, a nonrenewable resource. The manufacture of vinyl flooring and other PVC products produces dioxin, a persistent environmental toxin. In addition, vinyl is less durable than linoleum, requiring more material change-outs over the building’s life.

Benefits

Linoleum is a durable flooring material, often lasting three times as long as vinyl. It is easier to clean than carpet, and naturally inhibits microbial growth on its surface. Scratches, cuts, abrasion and cigarette burns in linoleum can be readily repaired.

Application

Resilient flooring is installed wherever a durable surface is needed, including entryways, hallways, kitchens, common areas and laundry facilities (for specific information about entryway flooring, see *Finishes & Furnishings: Measure 01*).

Linoleum comes in hundreds of colors and patterns in both sheets and tiles.

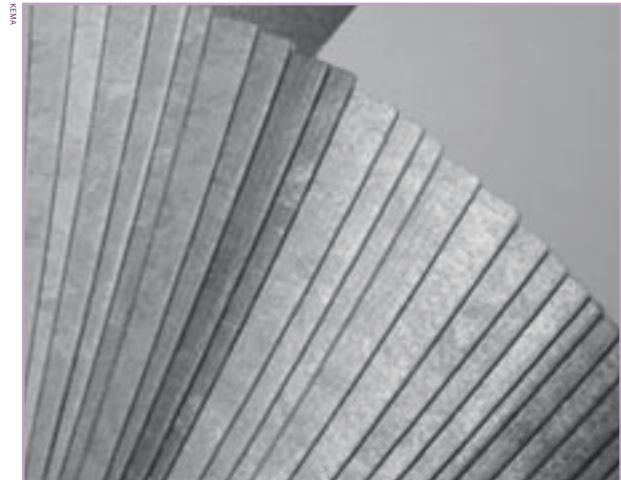

Natural linoleum is durable and easy to maintain.

Design Details



Linoleum installation is more complex than vinyl sheet or tile installation. *Be sure to use an installer certified by the manufacturer.*

Linoleum installation requires skilled labor; proper surface preparation, cutting and gluing require training. Linoleum must be installed on a smooth, dry surface.

Different adhesives are used with linoleum than with vinyl. Linoleum adhesives generally have very low or no VOC content. Do not allow contractors to use the same glues and methods for installing linoleum as they do for vinyl. Follow the manufacturer’s recommendation for adhesives.

In multifamily housing, linoleum should be finished with the manufacturer’s low-VOC surface treatment. Do not use waxes. Waxing introduces new, potentially harmful chemicals, and leads to the need for stripping and resealing the floor, increasing maintenance. In high traffic areas, sealers can be applied to increase resilience.

Code Considerations

The same code considerations apply to linoleum as to any other resilient flooring product.

For low-VOC emissions standards for resilient flooring, see the following documents:

- » State of California, South Coast Air Quality Management District Rule #1168 for adhesives and sealants: www.aqmd.gov/rules/html/r1168.html
- » Building Material Emission Study: www.ciwmb.ca.gov/GreenBuilding/Specs/Section01350/METStudy.htm (for information about this specification, also see *Finishes & Furnishings: Measure 05—Carpeting*)

Considerations for Residents

During the first week after installation, natural linoleum has a mild but unique odor that some occupants may not like.

Some manufacturers recommend that linoleum floors be cleaned by mopping them with water. Another method is to “dry” clean them with an electrostatic cloth mop that picks up dirt and dust. The latter does not require any chemicals or water, and the cloths are reusable.

Cost and Cost Effectiveness

| | | |
|---------|--------|--|
| BENEFIT | ★★★ | Installation must be done by specially trained contractors, which may increase cost. Linoleum takes longer to install than vinyl, which adds labor cost. Linoleum costs between \$3.00 and \$5.50 per square foot installed, depending on type and quantity. |
| COST | \$\$\$ | |

Linoleum generally lasts three times longer than vinyl, and is economical on a materials basis over a 15 to 20-year period. Generally, linoleum is selected for its health and environmental benefits, vibrant colors, and ease of repair rather than for its lifecycle cost benefits.

Resources

- » **Building Green**, publisher of *Environmental Building News*, has many linoleum resources: www.buildinggreen.com
- » **Green Resource Center** has a fact sheet, “Natural Linoleum Flooring”: www.greenresourcecenter.org
- » **California Integrated Waste Management Board’s** Section 01350, Building Material Emission Study www.ciwmb.ca.gov/GreenBuilding/Specs/Section01350/METStudy.htm
- » **U.S. EPA’s** air toxics website has information about vinyl chloride hazards: www.epa.gov/ttnatw01/hlthef/vinylchl.html
- » **Healthy Building Network** www.healthybuilding.net
- » **ACWMA’s** Materials Database lists products that correspond with this measure: www.multifamilygreen.org

WOOD FLOORING ALTERNATIVES

Consider FSC-Certified, Reclaimed and Engineered Wood, Cork and Bamboo

| WHO | KEY BENEFITS |
|---|--|
| <ul style="list-style-type: none"> ✓ Developer/PM Funder Policymaker ✓ Architect ✓ Builder ✓ Resident Building Manager | <ul style="list-style-type: none"> Health/IEQ Site/Community Energy Efficiency Water Efficiency ✓ Material Efficiency ✓ O&M ✓ Resident Satisfaction ENERGY STAR® |

09600: Wood Flooring

Recommendation

Instead of conventional hardwood flooring, use FSC-certified, reclaimed or engineered wood, or cork or bamboo.

Install as a glueless floating floor or glue with a low- or no-VOC adhesive. Specify factory-applied finishes, or seal with a low-VOC product.

Description

For market-rate multifamily housing, there are now many alternatives to traditional hardwood flooring, including FSC-certified or reclaimed wood, engineered wood, and rapidly renewable materials such as cork and bamboo.

SOLID WOOD FLOORING

Most high-quality, knot-free wood flooring comes from old-growth trees, which are not harvested sustainably. Finding alternatives to old-growth wood flooring protects forests and ecosystems *(for information on sustainable forestry and logging, see Structure: Measure 03—FSC-Certified Wood)*.

Traditional hardwood flooring comes from a huge variety of tree species, including oak, cherry, maple, walnut, mahogany and beech. Local flooring suppliers now supply FSC-certified wood in these common species and in tropical exotics.

Reclaimed wood is another way to have high-quality solid wood floors without cutting old-growth trees. Recovered wood comes from sources such as old buildings and railroad ties. It can be refinished or left with its natural blemishes *(for more about reclaimed materials, see Finishes & Furnishings: Measure 08)*.

ENGINEERED WOOD FLOORING

Engineered flooring is a popular alternative to solid wood. It has a thin layer of hardwood on top of a high-density fiberboard core. The result is the look and feel of solid wood without harvesting old-growth trees. Most engineered flooring products can be refinished at least once to extend their life.

Laminate floors have a highly durable wear layer applied over a thin veneer or paper image of wood. The substrate is high-density fiberboard or plywood. Like engineered floors, laminates can “float”; that is, they are not glued or nailed to the floor. Laminates have low first cost and are extremely durable when properly installed. Products with longer warranties are usually worth the extra cost.

RAPIDLY RENEWABLE FLOORING MATERIALS

Bamboo and cork are rapidly renewable materials known for their durability and beauty. Both can be harvested without destroying the plant, allowing them to regenerate and be reharvested in a relatively short time period. Cork and bamboo come in solid and engineered wood systems.

Full-grown bamboo stalks are cut lengthwise into narrow strips. The manufacturer glues these together to form flooring, plywood, paneling and other products. They are glued either horizontally in layers, or vertically in strips.

Cork is semi-malleable and absorbs shock and abuse. Cork is the outer bark of the cork oak tree. The tree is stripped of bark every 8 to 10 years, but survives to be harvested again and again.

Benefits

Reducing the amount of solid wood used in floors reduces demand for old-growth trees.

Application

Applicable anywhere hardwood flooring is specified (for resilient flooring options, see *Finishes & Furnishings: Measure 06—Natural Linoleum*).

Noise transmission is higher for wood-alternative floors than for carpet. Wood-alternative floors can be installed over hydronic heating systems, but are not effective for passive solar heating because of their relatively low thermal mass (*Systems: Measure 02—Thermal Mass Flooring*).



Before deciding to use cork, the property or operations manager should discuss concerns with the product manufacturer's sales rep. Cork is best used where proper maintenance will be performed.

Design Details

Bamboo, cork and laminates are extremely durable, often rating higher than oak in strength tests. Check manufacturer's literature for test results.

Cork, laminate and engineered flooring are sometimes assembled using formaldehyde-based glues in the substrate. Bamboo floors often use formaldehyde as a binder between strips (for more on formaldehyde in wood products, see *Finishes & Furnishings: Measure 09—Cabinets, Counters and Trim*). Sealing these products with a water-based finish once installed (if the finish is not factory-applied) is a good way to reduce formaldehyde offgassing. Not all water-based sealers are low-VOC. Avoid acid-cured lacquers that can emit formaldehyde during curing.

For flooring finishes, use low-VOC water-based products (*Sitework: Measure 04—Hazardous Materials and Waste*). Avoid alkyd and oil-based stains and finishes. If possible, have the stain and finish factory-applied to limit exposure of jobsite workers and occupants.

Wood and wood-alternative floors may or may not need to be glued to the substrate. When glued, specify a low- or no-VOC adhesive (*Finishes & Furnishings: Measure 03—Adhesives and Sealants*).

Code Considerations

None.

Considerations for Residents

Hardwood and wood-flooring alternatives don't trap dust and other particulates like carpet does. If cleaned regularly with nontoxic products, wood and wood-alternative flooring can provide better indoor air quality than carpet.

Many people highly value the beauty of hardwood and hardwood flooring alternatives.

Cost and Cost Effectiveness

| | | |
|---------|--------|---|
| BENEFIT | ★★★ | In the United States, the overall trend for hardwood flooring prices is upward, especially in the past 10 years. Alternative products are emerging as economically viable compared to wood and are expected to become increasingly attractive as more forests are clearcut and the supply of lumber from old-growth trees diminishes. |
| COST | \$\$\$ | |

FSC-certified hardwood flooring ranges greatly in price, from roughly \$4 to \$20 per square foot. Certified flooring made from exotic wood species can be quite low priced if the species is not well known. Popular species of certified flooring can carry a cost premium, however.

The cost of reclaimed wood depends on supply. Prices are volatile, but are frequently below \$5 per square foot.

Bamboo and cork flooring can be purchased for \$4 to \$9 per square foot. Engineered products range from \$3 to \$7 per square foot. Laminates are in the \$2 to \$5 per square foot range.

Resources

- » **Green Resource Center** has information on bamboo and cork flooring, and a list of local vendors: www.greenresourcecenter.org
- » **BuildingGreen** has information on alternative wood flooring products: www.buildinggreen.com
- » **Forest Stewardship Council** has Information on FSC-certified wood and suppliers: www.fscus.org
- » **ACWMA's** Materials Database lists products that correspond with this measure: www.multifamilygreen.org



Bamboo provides an attractive, resource-efficient alternative to wood flooring.

RECLAIMED MATERIALS

Reduce Landfill Waste by Using Reclaimed Materials

| WHO | KEY BENEFITS |
|--|--|
| <ul style="list-style-type: none"> ✓ Developer/PM Funder Policymaker ✓ Architect ✓ Builder Resident Building Manager | <ul style="list-style-type: none"> Health/IEQ Site/Community Energy Efficiency Water Efficiency ✓ Material Efficiency O&M Resident Satisfaction ENERGY STAR® |
| 01600: Product Requirements | |

Recommendation

Specify reclaimed materials wherever possible.

Description

Reclaimed materials, also called salvaged materials, can be used in many residential building projects. These materials come from many sources, including deconstructed or renovated buildings. Numerous organizations in the Bay Area accept reclaimed, overstock, old stock or misordered materials to be resold. Other companies will strip buildings of reusable components prior to demolition.

Common salvaged materials include timber, doors, sinks, fencing, bricks, tile, pipes, hardware and light fixtures. Reclaimed lumber is among the most widely available products, as studs, beams, flooring and trim.

Finding salvaged materials, especially for large projects, can be time consuming. Supply is inconsistent, which makes it difficult to plan for large quantities of materials. On small projects, however, using salvaged materials is often possible. There is a readily available supply of materials that can fit into small developments.

CLOSING THE LOOP

In addition to using reclaimed materials, another important waste reduction strategy is to donate unneeded materials. In the Construction and Demolition Waste Management Plan (*Sitework: Measure 01*), stipulate that appropriate surplus materials be resold or donated to salvage yards or nonprofit organizations. Also, some building products manufacturers will take back clean, unused scraps to be made into new products (for example, gypsum board, ceiling tile, carpet and fiber-cement products).

Benefits

Not only does salvaging and reusing materials reduce waste sent to landfills, it is also better than recycling from an environmental standpoint. The collection, transportation and processing of recycled-content materials uses energy and generates pollution. Reusing building materials—even if lumber needs to be remilled or doors have to be repaired and painted—typically generates less waste and pollution than recycling does.

Salvaged materials are often cheaper than new materials, and may be of higher quality. Salvaged timbers have tighter grains than some new wood, for example. Reclaimed materials can also help give a new building a distinctive character.

Application

Most applicable to small developments because of limited supply of matching salvaged products. On small projects, doors, lumber, hardware and other materials can often be found with little effort. Reclaimed materials can be challenging to incorporate into a large project.

Design Details

Salvaged timber can be used for most nonstructural applications. It's rare in structural applications because of the challenge of locating salvaged timber that has been regraded by a qualified wood grader.

Designing buildings to make use of standard-size building components can make it easier to incorporate salvaged products. It will be easier to match reclaimed doors to standard door openings, for example, than to nonstandard door openings.

Organizing materials on site (*Sitework: Measure 02—Efficient Use of Construction Materials*) will allow for quick separation of reusable materials for donation. Arrange for pickup of clean unused materials in good condition with local salvage yards, nonprofit organizations or manufacturers.

Code Considerations

Salvaged or reclaimed lumber may not meet structural requirements for some applications.

Some salvaged materials, such as single-pane windows, toilets that use more than 1.6 gallons per flush, and wood-burning fireplaces may not be allowed by state and local regulations.



A wide range of building materials are available at local salvage yards.

Considerations for Residents

There is usually no effect on occupants.

Cost and Cost Effectiveness

| | | |
|----------------|--------|--|
| BENEFIT | ★★★ | Some reclaimed products are very inexpensive, costing much less than new materials. Doors, for example, are widely available and can be found in small matching sets from most salvage companies. Other products, like salvaged flooring, are in higher demand and may have a price premium. |
| COST | \$\$\$ | |

Large quantities of matching reclaimed materials are difficult to find.

Resources

- » **ACWMA's *Builder's Guide to Reuse and Recycling*** lists local establishments for dropping off and buying recycled and salvaged materials. Search the Materials Database for product information: www.multifamilygreen.org

CABINETS, COUNTERS AND TRIM

Specify Low-Toxic and Durable Cabinets, Counters and Trim

| WHO | KEY BENEFITS |
|---|--|
| <ul style="list-style-type: none"> ✓ Developer/PM ✓ Funder Policymaker ✓ Architect ✓ Builder Resident ✓ Building Manager | <ul style="list-style-type: none"> ✓ Health/IEQ Site/Community Energy Efficiency Water Efficiency ✓ Material Efficiency ✓ O&M ✓ Resident Satisfaction ENERGY STAR® |

DIVISION 6: Wood & Plastics
06400: Casework, **06415:** Countertops

Recommendation

Cabinet boxes: Use medium-density fiberboard (MDF) with no added urea formaldehyde, or use exterior grade plywood and totally seal all edges.

Cabinet faces: Use solid wood, preferably reclaimed, reused or FSC-certified.

Counter substrates: Use MDF with no added urea formaldehyde, use a straw-based MDF or use totally sealed particleboard.

Trim: Use composite material with no added urea formaldehyde, use recycled plastic or use FSC-certified wood. Use durable wainscoting, chair rails and corner guards to protect walls from damage and reduce maintenance requirements.

Description

Durable cabinets, counters and trim save money and result in less waste. When selecting products made with composite woods, look for durability and low toxicity. Uncoated particleboard, for example, is prone to swelling when wet and can fall apart much more

quickly than other materials in kitchens and bathrooms. Many composite woods are produced with formaldehyde binders that offgas for a couple years after installation. The U.S. EPA classifies formaldehyde as a probable human carcinogen.

Formaldehyde glues in composite wood products come in two forms: urea and phenol. Urea-formaldehyde binders are more common. Phenol-formaldehyde binders are used in exterior applications because they help waterproof the wood; the waterproofing quality makes phenolic glues offgas more slowly and in lower quantities than urea glues, reducing harmful effects on indoor air quality. MDF, plywood and other face stock are available with no added formaldehyde; they use MDI (methyl diisocyanate) resins instead.

Alternatives to composite woods with added urea formaldehyde are: exterior-grade plywood; MDF with no added formaldehyde; powder-coated MDF; oriented strand board (OSB); and straw MDF. For higher-end applications, solid wood, bamboo plywood and biocomposites (wheat, straw or sunflower seed hulls) are possibilities. Trim products come in a similar range of materials, as well as recycled plastic.

Conventional wood products can be replaced with FSC-certified wood. These can be solid wood, plywood or MDF products (*Structure: Measure 03—FSC-Certified Wood for details*).

Benefits

INDOOR AIR QUALITY (IAQ)

To help protect IAQ, avoid interior products with added formaldehyde as much as possible. In low levels, it isn't considered harmful to humans. But with cabinetry, closed doors and drawers can allow the formaldehyde gas to collect and increase in concentration. When a cabinet is opened, a cloud of formaldehyde is released, often directly into the breathing zone.

RESOURCE CONSERVATION

Alternatives to wood include rapidly renewable raw materials grown and harvested within a 10-year cycle, such as bamboo, wheat straw and rice hulls. Using rapidly renewable resources reduces the use of trees and helps preserve forests.

CONSTRUCTION QUALITY

An advantage of plastic or engineered trim is straighter products with fewer imperfections than most solid wood trim. MDF board for cabinets also has very precise dimensions (especially thickness) and surpasses plywood, wheatboard and strawboard for this purpose.

Application

Mainly kitchens and bathrooms in affordable and market-rate multifamily housing.

Design Details

Focus on these areas when specifying cabinets:

1. **Substrate.** Use MDF or fully coated particleboard. Particleboard with exposed surfaces will fail in just a few years. Cabinet boxes are commonly made with particleboard, MDF or plywood sandwiched between a thin veneer of wood or melamine. Some cabinet manufacturers can substitute any of these materials. For a high-end look, wheatboard and MDF strawboard can be laminated with a bamboo veneer. In high-abuse installations, specify plywood boxes of 5/8-in. thickness or greater. Durable corner connections like tongue-and-groove or dowels will further increase the cabinets' longevity.
2. **Faces and doors.** Use solid wood for the cabinet faces, or at the least, use fully laminated MDF. Cabinet faces



These cabinets have MDF cores that contain no added formaldehyde.

made of solid wood provide an attractive and durable finish. A few manufacturers make bamboo faces (veneer or solid). FSC-certified woods should be used for solid wood applications.

3. **Hardware.** Use high-quality adjustable hinges that are appropriate for the level of abuse anticipated. For example, hinges in senior housing complexes may not require the strength and rigidity of other occupant types. In high-abuse situations, consider the difficulty of reattaching hinges to the substrate using existing screw holes. It is easier to rescrew hinges into plywood than into MDF or particleboard.
4. **Sealants and finishes.** Use water-based products with low-VOCs. Avoid alkyd and oil-based stains and finishes. Water-based wood sealers and finishes generally perform as well as or better than oil-based finishes. If possible, have the cabinets finished offsite to further reduce offgassing into the living space.

If particleboard or plywood with formaldehyde-based glues cannot be avoided, a low-VOC wood sealant applied to all six sides of cabinet materials will reduce formaldehyde

emissions. Specify two coats for best results.

For a painted look such as white melamine, consider powder coating. A low-temperature powder coating process can now be used on wood. Powder-coated cabinets, boxes, shelving and more are available. Powder coating is low in VOC emissions, highly durable, and seals in formaldehyde (for more about powder coating, see *Finishes & Furnishings: Measure 04*).

5. **Installation.** Screw the cabinets together and to the wall. To make repair, replacement and salvage easier, avoid gluing them in place. If rodents or roaches are potential problems, install cabinets with tight backs and escutcheons around plumbing and electrical penetrations, and caulk all cracks bigger than 1/16 in., such as between the wall and cabinets.
6. **Countertops.** Select durable countertop materials to fit the level of use and abuse the counters will experience. Where very high durability is important, include integral backsplashes to eliminate joint failure between countertop and walls. Keep in mind that wood butcherblock and solid surface materials will be susceptible to burn marks.

Code Considerations

None.

Considerations for Residents

Benefits include increased durability and reduced exposure to formaldehyde and VOCs.

Cost and Cost Effectiveness

| | | |
|----------------|--------|---|
| BENEFIT | ★★★ | Availability and cost range greatly. |
| COST | \$\$\$ | Most—but not all—options cost more initially than standard practice, but durable cabinets save money over time due to decreased damage and longer product life. |

Resources

- » **Department of Housing and Urban Development (HUD),** *The Rehab Guide*, Vol. 6 (Sept. 1999), "Improve Indoor Air Quality with Cabinetry": www.huduser.org/Publications/PDF/kitchen.pdf
- » **Green Seal,** "Particleboard and Medium Density Fiberboard," (Oct. 2001): www.greenseal.org/recommendations.htm/#product
- » **Environmental Building News,** Vol. 12 No. 11 (Nov. 2003), "Case Systems Switches to Straw-Based Particleboard": www.buildinggreen.com
- » **ACWMA's Materials Database** lists products that correspond with this measure: www.multifamilygreen.org

FURNITURE AND OUTDOOR PLAY STRUCTURES

Specify Durable, Healthy, Resource-Conserving Furniture and Play Structures

| WHO | KEY BENEFITS |
|--|--|
| <ul style="list-style-type: none"> ✓ Developer/PM Funder Policymaker ✓ Architect ✓ Builder ✓ Resident ✓ Building Manager | <ul style="list-style-type: none"> ✓ Health/IEQ Site/Community Energy Efficiency Water Efficiency ✓ Material Efficiency ✓ O&M ✓ Resident Satisfaction ENERGY STAR® |
| <p>12000: Furnishings</p> | |

Recommendation

Specify interior furniture that is durable, made from natural or recycled materials, recyclable, and/or made from low-toxic and low-emitting materials. Air out any new furniture to allow offgassing of VOCs.

Specify exterior furniture and play structures that do not utilize wood treated with chromated copper arsenate (CCA). Where applicable, use recycled plastic lumber products for site furnishings.

Description

Many furniture products are made with materials that may be harmful to people, to the environment, or both. They may require a lot of energy to produce, for example, they may release pollutants during manufacturing, or they may be unrecyclable. Some products, such as CCA-treated wood, are toxic to dispose of, creating difficulties for landfill and incineration operations. Some products, such as the stuffing material and fabrics used in many couches, chairs and beds, often release strong formaldehyde odors and volatile organic compounds (VOCs) for months.

INTERIOR FURNITURE

Over the past few years, the availability of low-toxic furniture for the commercial building sector has increased. But the residential furniture industry still lags. There are, for example, fewer low-emitting residential products available.

To help minimize the negative impacts of residential furniture, use these strategies:

1. Give preference to used furniture. It has already offgassed its volatile compounds, and using it reduces solid waste.
2. Unwrap new furniture inside units and let it air out with the windows open for a week. Take precautions against rain coming in.
3. Buy furniture made of solid wood or composite wood with no added formaldehyde. Specify FSC lumber if solid-wood furniture is to be built specifically for the project.
4. Buy repairable furniture. Fabric covers and stuffing should be easy to replace. Legs should be easy to tighten and replace.
5. Buy recycled-content furniture. Common areas for recycled materials are the frame and fabric (*Planning & Design: Measure 14*)
6. Buy furniture that is recyclable after its useful life.

OUTDOOR FURNITURE AND PLAY STRUCTURES

CCA is used to treat wood for many applications in construction and in outdoor furniture. Studies have shown that the disposal of CCA-treated wood poses a significant risk to the environment due to its arsenic and chromium content. Research also shows that play structures containing CCA-treated wood may be a risk for children. For these reasons, CCA-treated wood has come under intense scrutiny in the past few years. In response, the U.S. Environmental Protection Agency (EPA) and the treated wood industry reached an agreement to phase-out some uses of CCA-treated wood. As of December 31, 2003, most residential and playground uses of CCA-treated wood have been banned. Taking the place of CCA are two new treatment methods that do not contain arsenic: ACQ (alkaline copper quaternary) and copper boron azole (CBA).

Although CCA-treated wood is being phased out of production, there are still CCA-treated furniture and play structure products on the market. Check product literature and specifications carefully to ensure alternative products are used.

For outdoor furniture and play structures, recycled- plastic lumber can be a good alternative to wood. Also, garbage and recycling bins often contain high recycled content.

Benefits

Environmentally preferable furniture conserves natural resources. Durable hardware and furniture components extend the life of products, thus reducing waste and replacement costs.

For projects where a highly visible green image is desired, use alternative materials prominently in the furniture. Tables, shelves or closet doors made from engineered strawboard, for example, can enhance a project's green image.

Exterior products made without CCA-treated wood are less toxic to dispose of and may be healthier for children.

Application

Applicable to all projects. Furniture in multifamily buildings typically combines residential and commercial products. Residential furniture is found in units and in some recreational and common areas. Commercial furniture is generally used in lobbies, offices, main entry areas, hallways, clubhouses and shared laundry facilities. Play structures and outdoor furniture such as benches and trellises are often ordered from distributors.



Durable common area furniture.

Design Details

Consider these issues when selecting environmentally preferable furniture:

FURNITURE MANUFACTURERS

Check a company's website or literature for details on their environmental practices. Look for these characteristics when comparing manufacturers:

Made in California: California manufacturers are subject to the state's strict environmental regulations for emissions and waste disposal.

Efficient material use: Reuses scraps and leftovers in the manufacturing process or recycles them elsewhere.

Recycled materials: Promotes the recycled products industry by using recovered materials in their products.

Less packaging: Minimizes packaging to reduce waste.

MATERIALS

Select furniture made from environmentally preferable materials, including:

Wood products: Use wood composites with no added formaldehyde, reclaimed wood, and sustainably harvested wood (*Finishes & Furnishings: Measure 09—Cabinets, Counters and Trim / Finishes & Furnishings: Measure 08—Reclaimed Materials / Structure: Measure 03—FSC-Certified Wood*). Avoid CCA-treated wood.

Wood alternatives: Use wheatboard, strawboard or other agriboard products. Substitute wood for recycled plastic lumber where applicable.

Metals: Use metal with recycled content, and factory-applied paints or coatings (*Finishes & Furnishings: Measure 04—Metal Coatings*).

Plastics: Avoid polyvinyl chloride (PVC). Use recycled plastic or composite plastic products.

Foams: Avoid foams that use HCFCs as blowing agents (*Systems: Measure 08—High-Efficiency Air Conditioner with Advanced Refrigerant*).

Fabrics: Specify furniture made with low-toxic and low-VOC dyes and chemicals. Specify fabrics made from natural, renewable and biodegradable materials.

Finishes: Select products with low-VOC coatings, stains and paints.

Adhesives and glues: Select products with no added formaldehyde; select low-VOC products (*Finishes & Furnishings: Measure 03—Adhesives and Sealants*).

Recyclability: Select products that are easy to disassemble and recycle; consider using refurbished furniture.

Durability: Select furniture that is tough, reusable and upgradeable, or that contains reusable parts.

AIR OUT FURNITURE

Furniture, carpet and other absorptive materials can absorb odors, VOCs and airborne contaminants from building materials and construction practices. For example, some furniture is made with fabric and foam that are potential sponges for VOCs released from adhesives, sealants and paints. Perform a building flush-out and air out furniture to reduce this effect (*Sitework: Measure 03—Construction IAQ Management*). If schedule constraints don't allow for airing-out time, then place even more emphasis on purchasing low-emissions furniture.

Code Considerations

Most residential furniture does not meet fire code requirements in common areas. Refer to the California Technical Bulletin 133 Standards for more information (*see Resources section*).

CCA treated wood products are still legal for many construction uses. Some plywood, shake shingles, glue-laminated beams, and industrial or marine-grade products still use CCA.

Considerations for Residents

Using low-VOC products benefits occupants by reducing indoor air pollution. Non-CCA treated wood may reduce people’s exposure to arsenic.

Cost and Cost Effectiveness

| | | |
|----------------|--------|--|
| BENEFIT | ★★★ | When purchasing furniture, in addition to first-cost considerations, consider quality, durability and service needs. Inferior products may require more frequent maintenance, repair, replacement and disposal, which can ultimately increase costs compared to better quality, more durable products. |
| COST | \$\$\$ | |

Some environmentally preferable furnishings cost more because they are made with special materials. Also, some carry a price premium because they are popular with affluent customers who are interested in green design. One way to avoid paying artificially high prices is to steer clear of trendy materials when they first come out on the market. For example, bamboo flooring cost \$9 to \$15 per square foot in 1997 when it was introduced in the United States. By 2000, the number of suppliers had increased, and the material had lost some of its cachet for designers of luxury homes. Today, many companies install bamboo flooring for \$4 to \$6 per square foot.

ACQ- and CBA-treated wood products are slightly more expensive than CCA products.

Resources

- » **California Technical Bulletin 133** flammability standards for common-area furniture: www.bhfti.ca.gov/techbulletin/tb133.pdf
- » **LEED Reference Guide** has guidelines for airing out furniture: www.usgbc.org
- » **California Integrated Waste Management Board**, in conjunction with the Sustainable Buildings Taskforce, has created a Modular Office Furniture Specification. The specification is intended for state agency purchasing, but is also beneficial for others: www.ciwmb.ca.gov/GreenBuilding/Specs/Furniture
- » **ACWMA** has published a Fact Sheet on Recycled Content Park and Recreation Products in Alameda County and a Fact Sheet with Pointers on Using Recycled-Content Plastic Lumber: www.multifamilygreen.org
Tel. (510) 614-1699
- » **American Wood Preservers Institute’s** website lists all CCA treated wood products still being manufactured: Tel: (800) 356-2974, (703) 204-0500 www.preservedwood.com

Green design isn't over when the contractors pack up and the residents move in. To maximize the benefits of energy efficiency, durability and indoor environmental quality, green buildings must be properly operated and maintained over their entire life.

Building operation and maintenance shouldn't be an afterthought to the development process, and it shouldn't be reduced to a checklist of cleaning procedures and replacement schedules. It's important that the people who live and work in green multifamily housing be given information and encouragement so that they will be motivated to care for their homes, the common areas and the grounds. There are two important components to fostering this motivation:

- » Provide training and manuals to staff and residents so they have the

OPERATIONS & MAINTENANCE

information and resources necessary to properly operate and maintain the building *(Operations & Maintenance: Measure 01)*.

- » Provide signs, displays or tours to demonstrate important green features to residents, staff, the public and the media *(Operations & Maintenance: Measure 02)*.



BENEFITS

This table lists the Guidelines' Operations & Maintenance (O&M) measures, and shows the primary benefits of each (see the individual measures for details).

| MEASURE | BENEFITS | | | | | | | | | |
|--------------------------------|------------|---|-------------------|------------------|---|-----|-----------------------|--------------|---|--|
| | Health/IEQ | Site/Community | Energy Efficiency | Water Efficiency | Material Efficiency | O&M | Resident Satisfaction | ENERGY STAR® | | |
| 01 Training and manuals | ✓ | ✓ | ✓ | ✓ | ✓ | ✓ | ✓ | ✓ | | |
| 02 Educational signage & tours | ✓ | ✓ | ✓ | ✓ | ✓ | ✓ | ✓ | ✓ | ✓ | |
| EXPLANATION OF BENEFITS | | <p>Health/IEQ: Reduces indoor pollutants, promotes better indoor environmental quality, and/or provides opportunities for improved public health.</p> <p>Site/Community: Protects land, water and air on and near site from pollution or other environmental damage, uses municipal infrastructure more efficiently by redeveloping building or site, and/or provides important and needed amenities for the surrounding community.</p> <p>Energy Efficiency: Reduces building energy consumption.</p> <p>Water Efficiency: Reduces water use in building and/or on site.</p> | | | <p>Material Efficiency: Reduces, reuses and/or recycles materials that might have otherwise ended up in landfills, reduces materials needed to construct or operate the building, and/or uses materials produced in a way that minimizes environmental damage.</p> <p>O&M: Increases building's durability, and/or reduces operating and maintenance expenses.</p> <p>Resident Satisfaction: Saves residents money and/or improves residents' quality of life.</p> <p>ENERGY STAR®: Helps achieve ENERGY STAR® for Homes certification.</p> | | | | | |

KEY CONSIDERATIONS

INTEGRATED DESIGN

Good operation and maintenance practices actually start not with the building manager but with the developer and the architect, and should be addressed early in the design process. Specifying high-quality, durable, vandal-proof materials will make a project easier to maintain over time. Site and building designs that encourage community interaction will instill pride in residents and deter crime (*for detailed recommendations on design strategies that provide the foundation for a well-maintained, durable project, see the Planning & Design section*).

COMMISSIONING

Green building guidelines for commercial construction often recommend that commissioning be a part of the integrated design process. Commissioning is a systematic process of ensuring that all new building systems perform and interact according to original design documents and the owner's intentions. However, in multifamily residential projects—and in affordable housing projects in particular—commissioning per se is not generally performed. One reason is that building systems in large commercial buildings tend to be much more complex than those in small-scale multifamily buildings. Also, affordable housing developers often own and operate their projects or represent the owner's interests, so they are typically closely involved in the design process and perform a high level of testing during construction. Design teams might want to explore the benefits of commissioning if they are developing a large, high-rise multifamily project with complex building systems.

COST

Over the life of a building, O&M costs will greatly outweigh construction costs, so it makes sense to take steps to design a durable, energy-efficient, low-maintenance building. No matter how well designed, however, every building needs to be properly operated and maintained if it is to perform well year after year. Energy-efficient homes, for example, will only offer substantial long-term cost savings if occupants understand how they work. This is especially true for design strategies that people may be unfamiliar with, such as passive solar heating.

It does take time to develop manuals, signage and displays and to provide O&M training to staff and residents. While it's difficult to quantify the cost savings that result from these efforts, it is reasonable to assume they will contribute to a healthier, longer-lasting, more energy-efficient building.

MARKETING AND COMMUNITY RELATIONS

Educational displays and tours can be an important marketing tool for developers. For affordable housing projects, these efforts can enhance a developer's reputation among stakeholders including community and political leaders and funders. For market-rate housing developers, displays and tours can attract positive media attention, which may help drive interest from potential tenants and buyers.

ROLES AND RESPONSIBILITIES

- » **Developer and project manager.** Don't wait until construction is complete to address O&M strategies; instead, make O&M an integral part of the development process. Designate a party to be responsible for assembling O&M manuals and developing training. Work with local officials to provide transit passes for residents.
- » **Architect.** Incorporate design strategies that promote safety and security. Specify low-maintenance materials and products. Assist with compilation of materials for training and maintenance manuals.
- » **Building manager.** Make sure all O&M procedures support the project's green goals. Provide residents with training and manuals upon move-in that illustrate how to operate and care for their homes. Train maintenance staff so that they understand their role in contributing to maintaining a healthy and green building. Coordinate the implementation of transit passes.



Free transit passes (Ecopasses) were developed for residents of an affordable housing development in the Bay Area. (*Operations & Maintenance: Measure 01—Training and Manuals*)

TRAINING AND MANUALS

Provide Residents and Staff with Training and Information

| WHO | KEY BENEFITS |
|---|---|
| ✓ Developer/PM Funder Policymaker | ✓ Health/IEQ ✓ Site Protection |
| ✓ Architect ✓ Builder | ✓ Energy Efficiency ✓ Water Efficiency |
| ✓ Resident ✓ Building Manager | ✓ Resource Efficiency ✓ O&M ✓ Resident Satisfaction ENERGY STAR® |

Recommendation

Provide tenants, homeowners and maintenance staff with training and manuals on building operation and maintenance. Provide information on nearby transit where applicable.

Description

To maximize the benefits of energy efficiency, durability and indoor environmental quality, green buildings must be properly operated and maintained. Over the life of a building, operation and maintenance costs will greatly outweigh construction costs.

Energy-efficient homes, for example, can only offer substantial long-term cost savings if occupants understand how the systems work. This is especially true for strategies that people may be unfamiliar with, such as passive solar heating.

Materials used in green buildings sometimes require different maintenance procedures to prolong their life, such as using nontoxic cleaners. Educating residents and staff on proper procedures will help extend product life and maintain healthier interiors.

Some developments are located adjacent to public transit. In these instances, consider erecting a transit kiosk or otherwise provide information on travel in the local area. Work with local jurisdictions to incorporate bus stops or other public transit options to residents.

Benefits

Benefits include reduced energy costs and fewer product replacements. By actively involving residents and staff in taking care of their building, owners can help instill a sense of respect for the development. This can create a

good relationship between occupants and owners, and increase the perception of safety by fostering community interaction (*Planning and Design: Measure 06—Design for Safety*).

Application

All new residents should go through a basic training session that highlights the home's key green and maintenance attributes. Along with the residency agreement, provide a manual with information that reinforces the training.

Providing training to maintenance staff and building operators on operation and maintenance procedures. A detailed manual should be available for easy reference. The manual will also be useful for quickly training new employees.

Tours and signs can help reinforce the preferred operation and maintenance practices (*Operations & Maintenance: Measure 02—Educational Signage and Tours*). Tours can also include local transit options so that residents can become familiar with the neighborhood.

Design Details

Provide information to residents through a combination of trainings, manuals or signs:

- » **Energy efficiency:** Discuss how to operate appliances, thermostats and lighting to save energy. Where applicable, discuss methods to improve passive solar heating and cooling performance, such as furniture placement, paint colors and shading devices (*Systems: Measure 01—Passive Solar Heating*). Illustrate how window operation can influence natural ventilation (*Systems: Measure 07—Avoid Air Conditioning*).
- » **Finishes:** Discuss why the products were chosen, what makes them green, and how to maintain them to ensure a long life.
- » **Indoor air quality:** Explain the steps that were taken to provide good IAQ. Discuss healthy maintenance practices, including nontoxic cleaners and low-VOC consumer products. Provide details on how to get products replaced or repaired.
- » **Recycling and community facilities:** Provide details on recycling, ride-sharing, central laundry and community programs.
- » **Natural surveillance:** Discuss design elements that help provide safety (*Planning & Design: Measure 06—Design for Safety*).
- » **Eco-passes:** Some developments provide transit passes that provide residents with free use of local mass transit. These “eco-passes” are most suited to multifamily residences in urban environments.
- » **Post-construction tour:** allow future residents to tour the site during the last phase of construction to create a sense of ownership.

Provide residents with a small resident’s manual that, at a minimum, includes:

- » Product manuals for all installed appliances.
- » Tips on how to save energy (for example, PG&E fact sheets or similar publications).
- » Cleaning procedures for the green building materials (*Finishes & Furnishings: Measure 06—Natural Linoleum*).
- » A copy of Fannie Mae’s Guide to Buying and Maintaining a Green Home.
- » A list of environmentally preferable cleaning products (ACWMA’s “Recipes for a Healthy Home” is a good resource).
- » Information on pollution reduction steps taken, such as low-VOC paints or integrated pest management. Encourage residents to embrace the same principles in their own purchases and activities.
- » Information on detecting early signs of mold and steps to prevent, remediate or get help with mold.
- » Print the manual double-sided and on recycled paper.

DURING CONSTRUCTION

Add requirements in Construction Documents that require the contractors to train the maintenance staff upon completion of construction. Also include language in CDs to ensure that the subcontractors provide all necessary information for the manuals.

MAINTENANCE AND STAFF



Provide training to all new staff members and regularly check compliance by keeping a record of training sessions. A comprehensive manual that includes the following should

be readily available to all employees:

- » Maintenance schedules for all areas and finishes.
- » A list of required cleaning products for each green building material. Specify low-toxic and biodegradable products wherever possible. Include product names, ordering information and cleaning instructions; ideally, products should be available locally. Keep on hand an adequate inventory of the required cleaning products.
- » Cut-sheets of everything in the home that may need replacement or repair in the future. Includes electrical boxes, switches, wall coatings (paint colors and brands), toilets, sinks, faucets, hardware, flooring, towel bars, replacement tile and more. Keep on hand an assortment of the most frequently replaced items.
- » An extra set of plans for staff to refer to when working with service personnel.

- » Information on proper disposal techniques for hazardous and nonhazardous waste.
- » A vandalism management plan (*Planning & Design: Measure 07—Vandalism Deterrence and Management*).

Code Considerations

None.

Considerations for Residents

Occupants will better understand how to improve their home’s energy efficiency and indoor environmental quality, be better acquainted with the development and have a stronger connection to the community.

Cost and Cost Effectiveness

| | | |
|----------------|----------|--|
| BENEFIT | ★★★ | Developing, assembling and re-producing manuals can take time. Providing trainings to tenants and maintenance staff will be an additional task for property managers. However, once a system is in place, the process can be repeated for all new developments. Cost savings from reduced operation and maintenance costs are hard to quantify but are possible with such a program. |
| COST | \$\$\$\$ | |

Compiling materials to include in the manuals should be coordinated with the general contractor and architect before construction starts. These tasks generally don’t cost anything but require perseverance to collect all paperwork.

Resources

- » **ACWMA** had published a Fact Sheet on Environmentally-Preferable Janitorial Paper Supplies and the *Guide to Recycled Content Janitorial Paper Products in Alameda County*.
- » **“Recipes for Healthy Home”**: <http://household-hazwaste.org/alternatives.html>
- » **Fannie Mae’s** book, Home Performance Power: Fannie Mae’s Guide to Buying and Maintaining a Green Home. Nonprofits may order 50 free copies per month; order code HI274: Tel. (800) 7FANNIE www.fanniema.com/newsreleases/2000/1137.jhtml
- » **Mothering** magazine has good online articles about nontoxic housecleaners: www.mothering.com/10-0-0/html/10-3-0/non-toxic-cleaning.shtml
- » **PG&E** has fact sheets on energy savings: www.pge.com

EDUCATIONAL SIGNAGE AND TOURS

Teach People about the Project's Green Features

| WHO | KEY BENEFITS |
|--------------------|-------------------------|
| ✓ Developer/PM | ✓ Health/IEQ |
| ✓ Funder | ✓ Site/Community |
| ✓ Policymaker | ✓ Energy Efficiency |
| ✓ Architect | ✓ Water Efficiency |
| ✓ Builder | ✓ Resource Efficiency |
| ✓ Resident | ✓ O&M |
| ✓ Building Manager | ✓ Resident Satisfaction |
| | ✓ ENERGY STAR® |

DIVISION 6: Wood & Plastics, DIVISION 10: Specialties

Recommendation

Provide instructional materials, signs or tours to explain the project's green building components.

Description

Signs, tours and displays can be effective ways to demonstrate important green features. Audiences may include tenants, maintenance staff, building operators, the public and local news agencies.

Place permanent displays and signs to highlight green building attributes. Brochures that enable self-guided tours can also be a good way to inform people about the project's environmental attributes and the maintenance and operating needs of the units. Regularly scheduled tours may help promote the project and its design elements.

Benefits

Signs, displays and tours provide opportunities to inform building residents and the public about the building's environmental design strategies and other beneficial features. By focusing on green building attributes, developers can convey a positive message to the community.

Application

Applicable to all multifamily projects. Even if a project includes only a few green building strategies, it is useful to make them known to residents and the public.

Design Details

SIGNS AND DISPLAYS

Many displays require little time to design and can be completed after construction. Displays with glazing that reveals the structure of walls should be conceived of during the design phase.

Contractors are available who can create displays about green building materials. Displays may include material samples, along with descriptions of what makes each product green. Include information on maintenance and performance.



Signs like this one, from the media tour of the Livermore Centex zero net energy home, highlight environmental attributes of materials.

Possible locations for signs and displays include:

- » **Common areas:** Hallways, lobbies and community centers are good locations for general displays about the project's goals and overall approach to green building.
- » **Landscaped areas:** Highlight native species, drought-tolerant plantings, and integrated pest management (IPM).
- » **Parking lots or entrance walkways:** Point out permeable surfaces, cool-site materials, recycled materials, FSC trim.
- » **Walls:** Have cutouts with vision glazing to showcase insulation materials or display samples of alternative insulation.
- » **Photovoltaics:** Interactive displays in the lobby showing the quantity of electricity generated on site can promote renewable energy and wise energy use.

TOURS

Tours can take place on a regular basis—perhaps bi-weekly or monthly when the project first opens, then at longer intervals as indicated by community interest and tenant turnover. Areas to highlight in tours include:

- » Design elements of the buildings, such as orientation and placement on the site
- » Landscaping design strategies
- » Mechanical rooms with high-efficiency equipment
- » Rooftops (if the building has PV panels or cool roofs)
- » Interior finishes that are durable, low-VOC, or have no added formaldehyde
- » Sustainable living practices including maintenance, cleaning products and furniture selection criteria

Code Considerations

None.

Considerations for Residents

In multifamily developments with high turnover of residents, signs and tours help educate new residents on how their homes were built and work. This, in turn, may increase the building's longevity as well as energy and water savings.

Occupants may also benefit from a sense of pride that comes from having something positive to show visitors and from learning about their homes.

Cost and Cost Effectiveness

| | | |
|----------------|---------|---|
| BENEFIT | ★★★ | Signs and exhibit display prices vary widely depending on complexity. |
| COST | \$ \$\$ | They can range from a few hundred dollars for a simple sign to many thousands for interactive displays. |

Resources

- » **LEED Rating System.** Innovation In Design section gives credit for interactive displays with signage (*see Credit Interpretation Ruling #0121-Idc11-092801*): www.usgbc.org
- » **ACWMA's Materials Database** lists products that correspond with this measure: www.multifamilygreen.org



This permanent green building display is built into an alcove. The display has pages that visitors can flip through to learn about green aspects of the building.



CASE STUDIES

CASE STUDIES

Fold TAB here

Tuck here

CARMEN AVENUE

Orientation, Orientation, Orientation

Allied Housing has designed a 30-unit community to be built in 2004–2005 on Carmen Avenue in downtown Livermore, California, across the street from a new library. The development was carefully planned from the outset to incorporate green design. Key features include passive solar cooling, natural ventilation, use of low-toxicity finish materials, extensive access for people in wheelchairs, a photovoltaic power system and a plan for jobsite waste minimization and recycling. The primary outdoor spaces are a central courtyard framed by the two buildings, and a parking lot in back.

The project architect's mantra during design was "orientation, orientation, orientation." Once a project's location is determined, the focus should be on getting the building orientation right to take advantage of solar access and prevailing winds, and to improve circulation patterns for residents.

LOCATION

Carmen Avenue, Livermore, California

PARCEL SIZE/DENSITY

1.04 acres;
30 dwelling units per acre

BUILDING TYPE

Two buildings (2- and 3-stories) with rental apartments

TOTAL SQ. FT.

24,558 sq. ft.

TARGET POPULATION

Low-income adults with physical disabilities, and women who have suffered domestic violence and are graduating from shelters into permanent housing.

NUMBER OF UNITS

30 total
Studios: 2
1-bedroom: 5
2-bedroom: 16
3-bedroom: 7

COMPLETION DATE

2005 (estimated)

OWNER/DEVELOPER

Allied Housing, Hayward, CA

ARCHITECT

Kodama Diseño Architects, San Francisco and Oakland, CA

GENERAL CONTRACTOR

Sunseri, Chico, CA

CONTACT FOR MORE INFO

Marie Lee, Executive Director
Allied Housing, Inc.
22245 Main Street, #204
Hayward, CA 94541

TEL 510-881-7310

FAX 510-881-7320

EMAIL mlee@alliedhousing.org

WEB www.alliedhousing.org



Project architects analyzed multiple plans to optimize solar orientation, open space, views and access. The site plan on the far left was ultimately selected; it places the building on an east-west axis with parking hidden at the rear.

■ What Makes it Green ■

ENERGY

The developer is taking a comprehensive and integrated approach to green design at Carmen Avenue. But there is one fundamental element that stands out: Hot summer temperatures of 100°F and higher led Allied Housing and Kodama Diseño Architects to focus on heat gain and thermal mass, and to use the cool night air and the consistent afternoon breezes to make the design energy efficient and comfortable. The goal is to reduce the need for air conditioning to the point where it is rarely needed.

Some of the solar measures, like orienting the buildings along an east-west axis, took time to work out, but will cost nothing extra to build. Other measures, like the 3-foot overhangs, have a price tag, but will significantly reduce cooling loads and the tenants' energy bills. The table below shows how the design team approached the challenge of getting the cooling loads close to zero, beginning with the building orientation.

Cutting the Cooling Loads

- | | | |
|--|---|---|
| <p>1. BUILDING ORIENTATION – Elongated along east-west axis</p> <p>2. GLAZING PLACEMENT – Almost all glazing is on true south and true north facades</p> <p>3. GLAZING TYPE & WINDOWS – Low-e² insulated glazing with vinyl windows</p> <p>4. ROOF INSULATION – R-38 loose-fill cellulose</p> | <p>5. WALL INSULATION – R-19 fiberglass batt with no added formaldehyde</p> <p>6. OVERHANGS & TREES – Deep 6-foot overhangs on the south facade of one building; more modest 3-foot overhangs on the south facade of the other building. One large tree will be preserved in the courtyard between the two buildings.</p> | <p>7. FLOOR MASS – Outdoor walkways are concrete deck; interior floors are not mass construction</p> <p>8. WALL MASS – 5/8-inch gypboard on all walls and ceilings</p> <p>9. RADIANT BARRIER – Yes</p> <p>10. ATTIC VENTING – Ridge vent</p> <p>11. SEALING DETAILS – Sill plate gasket, outlet gaskets, caulking, taping and more</p> |
|--|---|---|

The apartments will also have combined water/space hydronic heating systems, ENERGY STAR® appliances, and fluorescent lighting in bedrooms as well as the kitchens and baths. An energy-efficient Kone Ecodisc elevator has been specified. Finally, a significant portion of the electricity needs will be met by a rooftop solar photovoltaic power system.

MATERIALS

In the spirit of “reduce, reuse, recycle,” the project team focused on minimizing jobsite waste by specifying factory-built walls, setting up a plan to donate unused construction materials, and writing a Section 01505 construction and demolition waste management plan. Construction materials were selected for durability, mold avoidance, nontoxicity and recycled content. Dozens of green materials were specified, including high-volume flyash concrete, fiber-cement siding, engineered lumber, FSC-certified roof trusses and OSB sheathing. Floors are finished with recycled content carpeting and natural linoleum.

HEALTH

The apartments are insulated with fiberglass batts with no added formaldehyde. All interior paint is low-VOC. Wherever possible, metals will be prefinished to avoid using oil-based paints in the field. Ceramic tile, natural linoleum and low-emission carpet are planned for the flooring.

GREEN at a GLANCE

Key green aspects of Johnson Creek Commons are listed here.

PLANNING & DESIGN

- Proximity to public transit and neighborhood services
- Parking in back helps create pedestrian orientation
- Orientation for passive solar cooling, natural ventilation and community interaction
- Low-water landscape
- Existing mature tree preserved onsite
- Universal design

SITework

- Section 01505 C&D waste management plan
- Plan to donate unused construction materials

STRUCTURE

- High-volume recycled flyash concrete FSC-certified roof trusses
- Engineered lumber and OSB sheathing
- Factory-built walls to minimize waste
- Roof insulation: R-38 loose-fill cellulose; radiant barrier
- Wall insulation: R-19 fiberglass batt with no added formaldehyde
- Fiber-cement siding
- Low-e² double-glazed windows with vinyl frames

SYSTEMS

- Passive solar cooling and thermal mass (concrete deck walkways, 5/8-in. gypboard)
- Combined water/space hydronic heating
- Sealing details: sill plate gasket, outlet gaskets, caulking, taping
- Fluorescent lighting in bedrooms as well as kitchens and bathrooms
- Photovoltaic system
- Energy-efficient Kone Ecodisc elevator
- ENERGY STAR® appliances
- Central laundry
- Good quality faucet aerators and low-flow showerheads

FINISHES & FURNISHINGS

- Low-VOC interior paint
- Prefinished metals
- Recycled plastic benches
- Ceramic tile, natural linoleum and low-emission carpet

WATER

The landscape was designed to use very little water. With the exception of a small grassy play area, the plants are drought tolerant and many are native. The irrigation system uses high efficiency bubblers and drip to deliver water more efficiently than pop-up sprayers. ENERGY STAR® dishwashers, good quality faucet aerators and low-flow showerheads will also save water.

COMMUNITY DESIGN

Parking was moved to the rear of the site so that the homes could connect with the surrounding community. The site is located on two bus lines and within a short walk of a grocery store and public library. The contractor is planning to preserve a large mature tree in the courtyard. A central onsite laundry room saves capital and operating costs and space while providing commercial-grade washers and dryers that clean clothes better than residential machines.

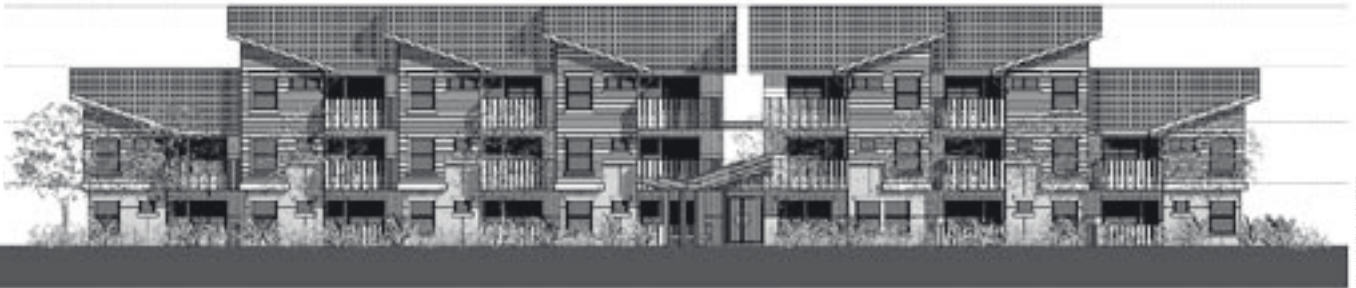

KODAMA DIBENO ARCHITECTS

■ Tips from the Trenches ■

Spend most of the design time and budget on low-tech solutions. Start the design of HVAC and lighting by trying to minimize or even eliminate anything that uses power or requires regular maintenance. Passive features that use standard construction materials are sometimes less expensive upfront, and are always less expensive over time. At Carmen Avenue, the passive features include the solar orientation; 5/8-inch gybboard throughout for thermal mass; exterior walkways to form deep south-facing overhangs; high-performance glazing; and high interior volumes for ventilation and daylighting. Only after maximizing the low-tech features should effort be spent on designing HVAC and lighting systems and controls.

Don't exclude good ideas early on just because they seem expensive. The Carmen Avenue buildings were designed from the start with large open roof areas sloping towards true south at an ideal solar pitch to allow for the possibility of installing photovoltaics. Recognizing that nothing ever gets funded that isn't already in the design, the team designed the solar electric system before funding was found. Good ideas, even if they seem expensive, should be kept on the table at least until the end of design documents. You may find money for it, you may find a cheaper method, or you may find a good deal that you weren't aware of.

In some areas technology is advancing rapidly. Elevators without machine rooms, for example, carried a significant premium when design began, but

by the middle of construction documents their prices had fallen to nearly match traditional systems. Similarly, the estimated labor cost for installing the photovoltaic system fell dramatically during the year of design work. The bottom line is that cost information more than three months old is obsolete.

Encourage team members to learn from experienced colleagues. ACWMA had requested that high-volume flyash concrete be used on the Carmen Avenue project. The contractor had used this material before and was quick to accept it. On your projects, if your contractors aren't familiar with high-volume flyash mixes, telling them that it reduces landfill waste isn't likely to win them over. Instead, have your contractors talk with other contractors who have successfully used high-volume flyash concrete.

Put green product sales representatives to work. When making a case for lifecycle cost benefits or when managing the submittal process in construction, get product representatives to support you. Many sales reps have PowerPoint presentations, lifecycle cost analysis spreadsheets and studies that support the use of their products, and some will provide assistance with submittal review and even provide oversight of the installation. Linoleum flooring is a good example of a product that is widely recommended because of its durability and nontoxic nature, yet it requires a higher level of technical knowledge to install properly. On the Carmen Avenue project, Forbo Linoleum reviewed specifications and will oversee the installation.

■ Financing ■

Green building features were designed into this project from the beginning.

SITE ACQUISITION COSTS \$1 million

DEVELOPMENT COSTS

Construction \$6 million
 Soft costs \$3 million
 Total \$9 million

MAJOR FUNDING SOURCES

City of Livermore \$2.5 million
 County of Alameda \$0.6 million
 State MHP \$2.1 million
 4% tax credit \$2.8 million
 Permanent loan \$1.5 million
 HUD \$0.5 million

AVERAGE COST/SQ. FT. \$360/sq. ft.

AVERAGE COST/UNIT \$330,000

AFFORDABILITY TARGETS

30% of area median income 11 units
 50% of area median income 18 units
 Onsite property manager 1 unit

CARMEN AVENUE

This Case Study was written by the Alameda County Waste Management Authority as part of its Multifamily Green Building Guidelines. To obtain the Guidelines and many other waste-reduction and green building publications, visit www.multifamilygreen.org or call 510-614-1699.

THE BREAKERS AT BAYPORT APARTMENTS

A Good – and Affordable – Fit



Resources for Community Development (RCD) is

developing a 62-unit project to be built in

2004–2005 within a neighborhood of single-family houses on Alameda Island. Because of the scale of the existing homes, the city limited the height of the multifamily project to two stories. This project's green building features need to "fit in," meaning they cannot look drastically different from the surrounding homes.

Key green building attributes will include hydronic heating, 2x6 stud walls insulated to R-19, efficient fluorescent lighting in most rooms, and low-emission cabinets. Some units will have low-e windows with vinyl frames, and all ground-floor units will be built with natural linoleum flooring. The only green elements noticeable to the neighbors will be onsite bioswales and drought-tolerant landscaping. In the Bay Area, low-water landscaping techniques are common even among high-end homes, so this feature was acceptable to the community.

LOCATION

Alameda, California

PARCEL SIZE/DENSITY

3 acres;
21 dwelling units per acre

BUILDING TYPE

2-story; 52 rental and
10 for-sale units

TOTAL SQ. FT.

65,300 sq. ft. (net)

TARGET POPULATION

Families with low incomes

NUMBER OF UNITS

62 total
2-bedroom: 34
3-bedroom: 28

COMPLETION DATE

2005 (estimated)

OWNER/DEVELOPER

Resources for Community
Development, Berkeley, CA

ARCHITECT

JSW/D Architects, Berkeley, CA

GENERAL CONTRACTOR

Segue Construction,
Point Richmond, CA

CONTACT FOR MORE INFO

Brian Saliman
Resources for Community
Development

TEL 510-841-4410 ext. 17

Debbie Potter
City of Alameda

TEL 510-749-5800

Pedestrian paths through the community lead to an exceptional community center with an after-school care program.

■ What Makes it Green ■

ENERGY

The building shell is insulated beyond code requirements with R-19 batt insulation in the walls and R-38 loose-fill in the attics. As part of the design assistance offered by ACWMA, raised heel trusses were recommended. The architect was pleased that this low-cost item would improve energy efficiency, and the contractor verified that the additional cost, if any, would be very small.

Some of the double-pane, vinyl-frame windows will have low-e glazing. The drywall is 5/8-inch thick, which helps improve the sound separation between units. An efficient combined hydronic system provides space and water heating. Fluorescent lights are used throughout the homes, except in the dining areas where people generally prefer dimmable lights (dimmable fluorescent fixtures are available but cost considerably more than nondimmable fluorescent fixtures).

MATERIALS

Durability is a major focus of this affordable housing project, so the architect selected low maintenance fiber-cement siding, 30-year roofing, and high quality hinges for cabinets. The Hardiplank fiber-cement siding is composed of cement and recycled wood fibers and is designed to look like traditional wood siding. Linoleum flooring was too expensive to include in all the units, so a decision was made to install it in all the ground-floor units, where the installation was least expensive. On upper floors, the lightweight gypcrete would have made it necessary to add an additional layer of plywood subfloor on top to guarantee proper adhesion of the linoleum.

Recycled flyash is specified to replace 28% of the cement in concrete, helping reduce CO₂ emissions associated with cement production and helping keep flyash out of landfills. Exterior benches are made from a composite of recycled plastic and wood fiber.

The architect incorporated ACWMA's model specification 01505 for a construction and demolition waste management plan. The architect and developer reviewed the implications of this specification with the contractor. The material recovery facility in nearby San Leandro is currently achieving close to 70% recycling rates from mixed construction debris boxes, so high jobsite recycling levels should be possible on this project.

HEALTH

To help protect indoor air quality, the design team specified low-VOC paints and glues, fiberglass insulation with no added formaldehyde, and low-emission carpet and linoleum.

The design team also specified medium-density fiberboard (MDF) cabinets instead of particleboard or other cabinet materials that contain urea formaldehyde. While the cost of MDF cabinets may be slightly higher, they are expected to last longer and provide better air quality. The contractor's green building allowance (see Tips from the Trenches below) made it easier to consider items like this that add upfront costs but offer long-term benefits.

GREEN at a GLANCE

Key green aspects are listed here. To learn about incorporating these and other green features in your project, turn to the appropriate section of the *ACWMA Multifamily Green Building Guidelines*.

PLANNING & DESIGN

- Detailing for moisture shedding and mold avoidance
- Bioswales
- Drought-tolerant landscaping
- Drip and efficient spray irrigation
- Community center and social gathering spaces

SITework

- Construction and demolition waste management plan (ACWMA model specification 01505)

STRUCTURE

- 2x6 stud walls
- Raised heel trusses
- Wall insulation: R-19 fiberglass with no added formaldehyde
- Attic insulation: R-38 loose-fill
- 5/8-inch drywall
- Fiber-cement siding
- 30-year roofing
- Low-e, double-glazed windows with vinyl frames

SYSTEMS

- Combined hydronic system for space and water heating
- Fluorescent lighting throughout (except dining areas)
- ENERGY STAR® dishwashers
- Low-flow showerheads, faucet aerators and toilets

FINISHES & FURNISHINGS

- Low-VOC interior paints and glues
- Low-emission carpet
- Linoleum flooring in ground-floor units
- Low-emissions cabinets (MDF) with high quality hinges
- Recycled plastic benches

WATER

A low-water landscape plan includes drought-tolerant species and makes use of drip and efficient spray irrigation. Stormwater from the roofs and landscaped areas will be collected in swales between the buildings. The project team initially explored permeable asphalt and loose-laid pavers for stormwater runoff, but the price for these options was high and the dense soil made drainage problematic. Also, new stormwater requirements (NPDES) are steering projects toward swales and away from filters that require regular maintenance. The swales turned out to be the least expensive, and probably the best, option.

Inside, the homes will have ENERGY STAR® dishwashers, and low-flow showerheads and faucet aerators. The specifications give preference to 1.6 gpf toilets that are approved by the East Bay Municipal Water District. EBMUD's list of preferred toilets gives designers a tool to differentiate between all the 1.6 gpf toilets on the market and select one with better performance (some toilets rated at 1.6 gpf actually operate over 2.5 gpf once the original flapper valve is replaced).



ILLUSTRATION: JAWO ARCHITECTURE

COMMUNITY DESIGN

Early plans to centralize the laundry facilities were blocked by the city; officials were concerned that it would stigmatize the project because the neighboring single-family homes all have their own laundry hook-ups. Unfortunately, this made it necessary to devote more floor space and money to individual laundry machines, and the tenants will use approximately twice the energy and soap, and 40% more water for laundry. In the end, a central laundry was included in the community center to give residents the choice of whether to buy their own clothes washers and dryers or use the central facility.

On a positive note, pedestrian paths through the community lead to an exceptional community center with an after-school care program, including outdoor play areas and a computer room. Next to the community center is a pervious hard surface area with rolled decomposed granite, allowing water to drain into the soil, reducing runoff and municipal stormwater system volume.

■ Tips from the Trenches ■

Create a budget allowance for the contractor to pay for green measures with higher capital costs. Green design sometimes requires additional upfront investment. For market-rate housing, it may be possible to recover that

investment through higher rent or sale prices. But for affordable housing, it may be necessary to find creative ways to fund these upfront costs. At the Breakers at Bayport Apartments, the developer selected a contractor early in design and then explicitly designated a portion of their base budget to cover green building-related costs. By not making the total fee larger, Segue Construction, the general contractor, had a strong incentive to guide the green design toward one that could be built as simply as possible using standard construction practices. By starting with an expectation that money will be spent on green building, the process feels fair and doesn't get bogged down in controversies about basic green building concepts.

Focus on durability and mold avoidance. JSW/D Architects spent considerable effort detailing the project's waterproofing elements, including details such as flashing and capillary breaks at the bases of posts. The project's drawings include a diagram showing proper window flashing details, and specify particular materials to achieve the best results. Roofing elements are also important. Roof overhangs help keep water out of the walls as well as provide important shading. The roof has a 30-year warranty.

Hire an interested general contractor. The best way to keep costs in line is to hire a contractor who is willing to work with their subs to educate and train them if they are not familiar with particular green measures or materials. This helps counter the common practice of charging more for something just because it is unfamiliar.

■ Financing ■

The cost data shown in the table are for the 53 rental units. Data were not available for 10 units for sale at the time the case study was written.

SITE ACQUISITION COSTS \$1/yr long-term ground lease

DEVELOPMENT COSTS

Construction \$8.5 million + \$0.5 million contingency
 Total \$13.2 million

FUNDING SOURCES

4% tax credit partner \$5.3 million
 State MHP (Multifamily Housing Program) \$3.1 million
 Permanent debt \$2.4 million
 City of Alameda \$1.2 million
 General partner \$585,000
 Alameda County \$385,000
 AHP through Federal Home Loan Bank \$229,000

AVERAGE COST/SQ. FT. \$168

AVERAGE COST/UNIT \$174,000

AFFORDABILITY TARGETS

30% of median income 18 rental units
 50% of median income 23 rental units
 60% of median income 10 rental units
 80% of median income 10 for-sale units
 Onsite property manager 1 unit

MULTIFAMILY GREEN BUILDING GUIDELINES
CASE STUDY

THE BREAKERS AT BAYPORT APARTMENTS



This Case Study was written by the Alameda
 County Waste Management Authority as part of
 its Multifamily Green Building Guidelines.
 To obtain the Guidelines and many other
 waste-reduction and green building publications,
 visit www.multifamilygreen.org
 or call 510-614-1699.

BETTY ANN GARDENS FAMILY APARTMENTS

Mainstreaming Green



FIRST COMMUNITY HOUSING

The Betty Ann Gardens

affordable housing project in San Jose, California, demonstrates the successful confluence of mainstream construction practices with environmental sensibilities.

Completed in 2003, the 76-unit suburban development lies on 3.9 acres along the banks of the Penitencia Creek, a riparian preserve on North King Road.

This project exemplifies the goals of its San Jose-based developer, First Community Housing (FCH), to make a positive impact on the community “by building sustainable, high-quality, affordable housing developments and offering resident services that meet the needs of those who earn less than the area’s median income.”



LOCATION

North King Road at Berryessa Road, San Jose, California

PARCEL SIZE/DENSITY

3.87 acres;
20 dwelling units per acre

BUILDING TYPE

3-story building with rental apartments

TOTAL SQ. FT.

Floor area: 85,169 sq. ft.
Building footprint: 27,504 sq. ft.

TARGET POPULATION

Families with low incomes

NUMBER OF UNITS

76 total
1-bedroom: 16
2-bedroom: 36
3-bedroom: 20
4-bedroom: 4

COMPLETION DATE

August 2003

OWNER/DEVELOPER

First Community Housing, San Jose, CA

ARCHITECT

Office of Jerome King, AIA, San Jose, CA

GENERAL CONTRACTOR

Branagh Construction, Oakland, CA

OTHER

Engineering Network performed Title 24 analysis; Plogco Inc. provided HVAC design; Betty Ann Gardens, LLP, to own and operate; FCH will remain a general partner.

CONTACT FOR MORE INFO

Marty Keller,
Director of Construction Management
First Community Housing
2 N. Second Street, #1250
San Jose, CA 95113

TEL 408-291-8650 ext. 14

FAX 408-993-9098

EMAIL martyk@firsthousing.org

WEB www.firsthousing.org

The initial design approved by the City of San Jose was not specifically for a green building project. However, a change of staff at First Community Housing opened the door to more aggressive incorporation of green features. Since this happened after the project was well underway, it was too expensive to pursue major changes to siting and orientation. But it was still possible to include many green materials and efficient systems.

The development's key green building attributes include proximity to public transit, use of low-toxicity materials, energy-efficient lighting and appliances, and recycled-content roofing and flooring materials. Residential features are designed to encourage community interaction, and include a children's play lot, a community center with kitchen, activity rooms and offices, and lawn and mini-plaza areas.

■ What Makes it Green ■

ENERGY

Overall, the project uses 26% less energy than allowed by California's Title 24 energy code. All Betty Ann Gardens apartments feature ENERGY STAR® air conditioners, dishwashers, refrigerators and compact fluorescent lamps. ENERGY STAR® products save electricity and reduce residents' utility bills. Insulation above levels required by code and vinyl-frame double-glazed windows and sliding doors also help conserve energy and keep the homes comfortable. The apartments include combination water/space hydronic heating and cooling systems, which are generally more energy efficient and less costly to operate than conventional water heating and forced air systems.

MATERIALS

Many of the building materials used on this project contain recycled content or are otherwise resource efficient. Engineered joists and trusses and OSB sheathing were used in place of solid wood and plywood. Fiber-cement siding was substituted for solid wood siding, with the added benefit of greater durability and reduced maintenance. The community center's roof is a blend of cellulose fiber and 100% recycled plastic, molded to resemble slate tiles. All cabinets and trim are medium-density fiberboard (MDF) with no added formaldehyde; this material is manufactured with more than 90% preconsumer recycled wood. All carpeting contains recycled content, and carpet tiles, rather than large rolls, were installed so that worn sections can be selectively replaced.

GREEN at a GLANCE

Key green aspects of Betty Ann Gardens are listed here. To learn about incorporating these and other features in your project, refer to the appropriate section of the *ACWMA Multifamily Green Building Guidelines*.

PLANNING & DESIGN

- Bus stop in front of development; free public transit passes provided to residents
- Design for community interaction: children's play lot; community center with lounge, computer learning center, kitchen, activity rooms and offices; lawn and mini-plaza areas.
- Restoration and protection of nearby creek
- Preservation of existing trees onsite

STRUCTURE

- Engineered joists and trusses, and OSB sheathing
- Fiberglass batt insulation with no added formaldehyde
- Fiber-cement siding
- Community center roof: 100% recycled plastic and cellulose
- Double-glazed, vinyl-framed windows and sliding doors

SYSTEMS

- Combination water/space hydronic heating
- Compact fluorescent lights
- ENERGY STAR® air conditioners, dishwashers and refrigerators

FINISHES & FURNISHINGS

- Low-VOC interior paints and varnishes
- Recycled-content carpet tiles
- Linoleum flooring
- Cabinets and trim: MDF with no added formaldehyde; more than 90% preconsumer recycled wood



PHOTO: COMMUNITY DESIGN

HEALTH

To reduce harmful offgassing, batt insulation with no added formaldehyde was used, as well as MDF cabinets and trim (see Materials above). In kitchens and bathrooms, linoleum flooring was laid instead of vinyl. Low-VOC interior paints and varnishes were used throughout the project, which also help maintain good indoor air quality.

WATER

By restoring and protecting the nearby Penitencia Creek, project designers contributed to improved water quality and stormwater runoff management. Restoration work involved cleaning out garbage, replanting areas and adding temporary irrigation for the newly planted trees. Installation of ENERGY STAR® dishwashers helps reduce overall water and energy use. Unfortunately, due to the project’s relatively late integration of green building features, other water-conserving measures such as permeable paving and drought-tolerant landscaping could not be implemented without adding burdensome costs.

Betty Ann Gardens demonstrates the successful confluence of mainstream construction practices with environmental sensibilities.



PHOTO: COMMUNITY DESIGN

COMMUNITY DESIGN

A bus stop is located in front of Betty Ann Gardens and residents are provided free “Eco-passes” for unlimited use of local public transportation. The developer pays \$30 per person per year for these passes. A community center with lounge, computer learning center, activity room, kitchen and office space supports interactive community life. The site’s heritage trees have been protected, which, along with landscaped lawn and plaza areas, provide natural beauty, open space and recreational opportunities.

■ Tips from the Trenches ■

Embed green building features at the earliest stages. The decision to more aggressively pursue green building strategies came late, after the project had already received approvals from the City of San Jose. As a result, the project team had to work within the bounds of the approved design. Some green features, like changing the heights and orientations of the buildings, would have been feasible early on, but required changes in the City’s development approvals and were therefore technically and economically unfeasible at the later date. Fortunately, the general contractor accommodated the developer’s green building goals, and worked with the architect to develop an alternative set of cost estimates for the green features.

Work collaboratively throughout the process. From preliminary design through finishing touches, the project’s general contractor, developer and architect worked together in a highly collaborative environment. Goals and processes were established at pre-bid and pre-construction, which helped minimize change orders and contain costs. It wasn’t until after the initial design approval that a change in staff at First Community Housing precipitated the addition of more green building features. The developer presented alternative materials and practices and because of the existing collaborative relationship, these ideas were quickly evaluated and many were adopted.

■ Financing ■

Wherever possible, the developer worked with the architect and general contractor to incorporate green building practices in a cost-effective manner. Given the relatively late introduction of green measures, the project demonstrates practical green building strategies while staying within an acceptable budget.

SITE ACQUISITION COSTS \$2,720,000

DEVELOPMENT COSTS

Construction \$11,124,300
 Soft costs \$7,775,700
 Total \$18,900,000

FUNDING SOURCES

City of San Jose (loan) \$5,129,744
 City of San Jose (grant) \$934,370
 Tax credit limited partner \$6,058,696
 CitiBank \$7,610,000
 General partner \$66,065

AVERAGE COST/SQ. FT. \$130.61

AVERAGE COST/UNIT \$146,373

AFFORDABILITY TARGETS

30% of median income 8 units
 50% of median income 15 units
 60% of median income 52 units
 Onsite property manager 1 unit

MULTIFAMILY GREEN BUILDING GUIDELINES
CASE STUDY

**BETTY ANN
 GARDENS FAMILY
 APARTMENTS**

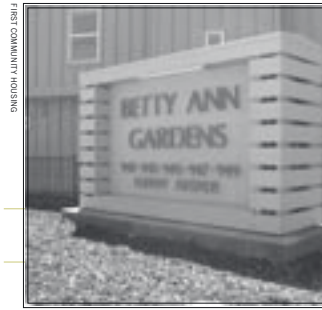

This Case Study was written by the Alameda
 County Waste Management Authority as part of
 its Multifamily Green Building Guidelines.
 To obtain the Guidelines and many other
 waste-reduction and green building publications,
 visit www.multifamilygreen.org
 or call 510-614-1699.

JOHNSON CREEK COMMONS

Giving New Life to an Aging Building



In 1998, an aging apartment complex in outer Southeast Portland, Oregon, was transformed by a green retrofit into a thriving community for residents with low

incomes. The community, called Johnson Creek Commons, includes a renovated 15-unit complex and a new duplex unit. Developed by Sustainable Communities Northwest (SCNW) and ROSE Community Development, the project helps address the area's lack of affordable housing.

As a retrofit project, Johnson Creek Commons might already be considered a green development, based on reuse of existing buildings and materials.

In addition, both the retrofitted units and the new duplex incorporate green attributes such as energy efficiency, water conservation, reduced waste, and improved indoor air quality. A common garden and other community features enhance residential life.

SCNW founder Rosemarie Cordello's guiding vision for the project was based on her philosophy that "living in a way that is healthy, that preserves resources, needs to be something that is accessible to everyone." Funding was provided by the Portland Development Commission and ShoreBank Pacific. SCNW has since closed, but the project is still owned and operated by ROSE Community Development.

LOCATION

Brentwood-Darlington neighborhood, SE 72nd Avenue, outer Southeast Portland, OR

PARCEL SIZE/DENSITY

0.9 acres;
17 dwelling units per acre

BUILDING TYPE

Existing two-story building with rental apartments; new duplex unit

TOTAL SQ. FT.

Apartments: 11,436 sq. ft.;
Duplex: 1,680 sq. ft.

TARGET POPULATION

Families with low incomes

NUMBER OF UNITS

17 total
1-bedroom: 1
2-bedroom: 16

COMPLETION DATE

August 1999 (apartment retrofit);
March 2002 (new duplex)

OWNER/DEVELOPER

Sustainable Communities Northwest and ROSE Community Development, Portland, OR

ARCHITECT

Duplex: Allen Scott and Chris Bensman Davis, Portland, OR

GENERAL CONTRACTOR

Retrofit: All Weather Remodeling, Portland, OR
Duplex: Longshot Construction, Portland, OR

OTHER

Duplex suppliers: Environmental Building Supplies; ReBuilding Center; Metro; American Aldes

CONTACT FOR MORE INFO

Mike O'Brien (former SCNW board member), Green Building Specialist, Office of Sustainable Development, City of Portland, Jean Vollum Natural Capital Center, 721 NW Ninth Ave., Room 350, Portland, OR 97209

TEL 503-823-5494

EMAIL mobrien@ci.portland.or.us

■ What Makes it Green ■

ENERGY

A key goal was to increase the apartments' energy efficiency. Floor insulation was increased from none to R-30. Existing walls had R-8 batt insulation; rigid foam insulation was added in conjunction with new siding. Ceiling insulation was upgraded from R-11 to R-38. Also, air tightness was increased through weather-stripping and caulking, and vapor barriers were installed in crawl spaces.

The single-pane aluminum-frame windows were replaced with double-pane, low-e windows with vinyl frames. The electric resistance baseboard heating was replaced with efficient radiant cove heaters high on the walls with separate thermostats by room. ENERGY STAR® appliances were installed, and conventional lights were replaced with compact fluorescent lamps in kitchens and bedrooms.

The energy efficiency retrofit cost \$43,942, and was so effective that payback was estimated to be 2.5 years. The new duplex included many of these energy efficiency features at the design stage.

MATERIALS

At Johnson Creek Commons, rotten wood siding on the apartments was replaced with Hardiplank, a fiber-cement product that is durable and uses less tree fiber than wood siding. Sinks, countertops, doors and other fixtures were replaced with higher quality salvaged products. And 90% of the lumber used in the duplex construction was salvaged from old buildings (see Financing section below for more information). Additionally, the duplex was built with advanced framing techniques, which use about 20% less lumber than traditional framing. The small amount of new wood that was used was FSC-certified to be sustainably harvested.

Long-lasting linoleum replaced the old vinyl flooring. Recycled-content carpeting was installed in units and common areas. Recycled latex paint was used for the exteriors, helping keep leftover paint from other projects out of the landfill.

WATER

The Portland Water Bureau worked with the project owners to undertake a water efficiency pilot program in the complex. Measures included installing flow-reducing devices in toilets and showerheads; replacing old washing machines with water-efficient front-loading machines; and using automated meter-reading technology to monitor the entire complex's water consumption. A water-efficient landscape design and drip irrigation system were installed. Bioswales in the parking area enabled the site to disconnect from the storm sewer system and instead divert stormwater runoff into landscaped areas.

HEALTH

At Johnson Creek Commons, linoleum replaced vinyl flooring. The linoleum was the only item that had a significantly higher first cost than standard materials, and it was chosen both for health and durability reasons.

GREEN at a GLANCE

Key green aspects of Johnson Creek Commons are listed here. To learn about incorporating these and other green features in your project, turn to the appropriate section of the *ACWMA Multifamily Green Building Guidelines*.

PLANNING & DESIGN

- Retrofit of existing building
- Community garden, playground, barbeque and picnic areas
- Water-efficient landscape design and irrigation system
- Bioswales for stormwater runoff

STRUCTURE

- FSC-certified wood
- Advanced framing
- R-30 floor insulation
- Rigid insulation added to existing walls
- Ceiling insulation upgraded to R-38 from R-11
- Vapor barriers installed in crawl spaces
- Fiber-cement siding
- Double-pane, low-e, vinyl-framed windows

SYSTEMS

- Efficient radiant cove heaters
- Weather-stripping and caulking
- High-flow fans in all bathrooms
- Compact fluorescent lights
- Energy-efficient appliances
- Flow-reducing devices in toilets and showerheads
- Water-efficient front-loading washing machines

FINISHES & FURNISHINGS

- Zero-VOC interior paint
- Recycled latex exterior paint
- Recycled-content carpet
- Linoleum flooring
- Salvaged lumber, sinks, doors and other fixtures
- Low-emissions cabinets



Double-pane, low-e windows were installed to increase energy efficiency.

The owners specified zero-VOC interior paints and cabinetry made of exterior-grade plywood with phenol formaldehyde (the waterproof phenol formaldehyde-based binders offgas much less than urea formaldehyde binders, which are typically found in interior-grade plywood). Given the high humidity levels of the Pacific Northwest, effective ventilation of bathrooms is especially important. Many apartments were first cleaned of mold, and high-flow Broan/Nutone fans were installed in all bathrooms to reduce moisture levels and inhibit mold growth.

COMMUNITY DESIGN

Under the guidance of SCNW, Johnson Creek neighbors worked collaboratively to design and plant a community garden, as well as create a playground and barbeque and picnic area. The original complex's parking lot was larger than needed, so the owners used part of it for the duplex, and included a retention pond and bridge as design elements to connect the new and retrofitted buildings.

“Living in a way that is healthy, that preserves resources, needs to be something that is accessible to everyone.”

– ROSEMARIE CORDELLO

■ Tips from the Trenches ■

Plan ahead. Some contractors were unfamiliar with some of the alternative building materials, or how to source them economically. The developers worked closely with their suppliers and contractors to prepare them for the project and make the appropriate product purchases. Some circumstances—such as weather conditions—were out of anyone's control. (The owners caution against installing windows during December storms, if at all possible!)

Provide ongoing support for community activities. Since project completion, resident participation in the community garden has waned. This is partially attributed to a lack of ongoing support from community agencies, whether through volunteer or paid staff. The Johnson Creek garden is still growing, but with involvement from fewer households than at the beginning of the project.

Expect challenges when retrofitting an occupied building. The developers did not want to displace residents during the retrofit, and therefore had to work carefully with contractors and residents to accommodate sometimes conflicting schedules. A representative of the owner personally went to talk with each family about what to expect during construction, which went a long way toward helping the work flow smoothly.



Salvaged countertops are used in the kitchens.

■ Financing ■

From the outset, this project was intended to show how low-income housing can be durable, healthy and environmentally responsible. The owners made a realistic assessment of which green building measures they could include, and prioritized key environmental goals: energy efficiency, resource conservation, low toxicity and durability. Some features, such as solar hot water or photovoltaics, were never considered, due to budget restraints. Other green items—such as wheatboard cabinetry, permeable pavers, and damp-spray cellulose insulation—were initially considered, but later rejected due to cost or availability barriers.

Still other items, such as hydronic heating for the duplexes, were installed with the perspective that the energy savings and reliability make this technology a good long-term investment. The duplex portion of the project also benefited from excellent support from the ReBuilding Center, which worked hard to supply the salvaged lumber package at a reasonable cost.

PROJECT FINANCES (15-UNIT RETROFIT PORTION ONLY)

| | |
|---|-----------|
| Site acquisition costs | \$660,000 |
| Retrofit and deferred maintenance costs | \$230,000 |
| Total | \$890,000 |

FUNDING SOURCES

| | |
|--|-----------|
| Portland Development Commission (equity gap grant) | \$284,622 |
| Portland Development Commission (loan) | \$350,000 |
| ShoreBank Pacific (loan) | \$242,010 |
| U.S. Bank (grant) | \$10,000 |

AVERAGE COST/SQ. FT. (RETROFIT) \$20

AFFORDABILITY TARGETS

| | |
|--------------------------------|----------|
| 30% of median income | 5 units |
| 50% of median income | 10 units |

JOHNSON CREEK COMMONS

This Case Study was written by the Alameda County Waste Management Authority as part of its Multifamily Green Building Guidelines. To obtain the Guidelines and many other waste-reduction and green building publications, visit www.multifamilygreen.org or call 510-614-1699.

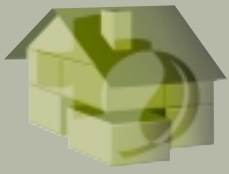

GLOBAL GREEN USA CASE STUDY

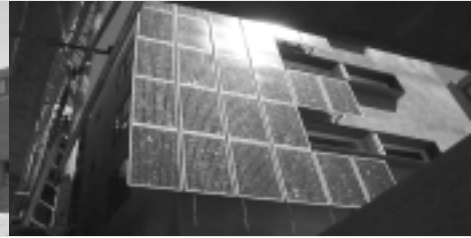

On-Site Energy Generation · Energy Efficiency · Landscaping/Site Planning · Resource Conservation · Indoor Environmental Quality

Colorado Court

502 COLORADO AVENUE, SANTA MONICA, CALIFORNIA

The Colorado Court project sets an ambitious new standard for energy- and resource-efficient affordable housing. An urban infill development, Colorado Court is located in a prominent location at 5th and Colorado in downtown Santa Monica, close to shops, jobs, civic buildings, and public transit lines.

The impetus to make the project a showcase of green technologies and design came from the City's involvement with the Regional Energy Efficiency Initiative, a program that supports municipal energy-efficiency demonstration projects. The City of Santa Monica Environmental Programs Division worked in cooperation with the City Housing Division, the Community Corporation of Santa Monica, and the project architects to identify and implement the green features.

PROJECT INFORMATION

Project Size:

29,900 s.f., 5 floors, 44 studio units

Construction Cost:

\$4.3 million

Completion Date:

April 2002

Owner/Developer:

Community Corp. of Santa Monica

Architect:

Pugh Scarpa Kodama

Energy Consultant:

Helios International, Inc.

Mechanical/Electrical Engineer:

Storms & Lowe

Structural Engineer:

Nabih Youssef & Associates

Contractor:

Ruiz Brothers Construction Co.

Construction Manager:

Guccione and Associates

Landscape Architect:

Dry Design, Inc.

GREEN FEATURES

Numerous environmental considerations were incorporated in the early planning and design stages of the project. The architects and energy consultant collaborated from the outset to minimize energy use and best utilize natural features such as the sun and prevailing winds.

The orientation and shape of the building and the placement of windows maximize natural daylighting and natural ventilation and provide shading where needed. Because of these passive design strategies, it was only necessary to provide air conditioning in one small area of office space.

The building's design and technologies allow it to achieve a level of energy efficiency that exceeds both the State of California Title 24 Energy Code and the local standards set by the City of Santa Monica's Green Building Design and Construction Guidelines.

The project's energy consultants expect that the building will exceed Title 24 efficiency standards by 50%, resulting in savings of almost \$10,000/year (as of June 2001 energy rates). The consultants also estimate that almost 100% of the power needed by the building's occupants can be generated on the site by solar photovoltaic panels and an on-site gas turbine. Over the course of a year, the site will probably produce more electricity than it consumes.

During and after construction, the energy consultants are conducting tests to ensure that the building's systems and equipment were procured as specified and are working as intended—a process known as commissioning. The commissioning evaluation will continue throughout the first year of the building's operation.

(Continued on Next Page)



In addition to the energy-efficient measures, the project includes design features, materials, and systems that address the building's impact on the site, water use, resource use, and tenant health and well-being (see list of features, below).

The building was designed to meet many of the rigorous criteria of the LEED (Leadership in Energy and Environmental Design) rating system, developed by the U.S. Green Building Council. The project has been registered for LEED certification and its owner and designers hope that it will attain the Gold rating.

On-Site Energy Generation

- Photovoltaic (PV) panels are integrated into the building facade and are on the rooftop. The 25-30 kW system will produce more electricity during the daytime peak hours than needed by residents. If the building is deemed eligible for net metering (see final paragraph of the case study), the surplus electricity that is generated on site can be sent to the power grid; the building owner will then be credited for that by the utility. During non-daylight hours, when the PV system does not operate, electricity will be generated by the turbine/cogeneration system and taken from the grid. However, the electricity obtained from the grid should be offset by the surplus sent into the grid. Therefore, under a net metering system, the residents' electricity bills should be zero.
- A 28 kW natural-gas-powered turbine with cogeneration (waste heat recovery) system operates in the early morning and evening hours, to meet the remainder of the electricity demand. This system also provides 100% of the building's domestic hot water needs and a substantial portion of the winter space heating requirements. This low-emission system has a conversion efficiency of approximately 70% (while primary energy delivered via the utility grid is only about 30% efficient). Also interesting to note is that, in California, the price of natural gas is discounted for consumers who use cogeneration systems.

Energy Efficiency

- Shading for south-facing windows
- Minimal glazing on the west facade
- Double-pane, low-E, krypton-sealed, high-efficiency glazing
- Compact fluorescent, low-mercury bulbs
- Indoor and outdoor motion sensors for lighting
- R-21 insulation throughout the building (recycled blown-in cellulose in 2x6 framing)
- R-30 insulation in the roof
- Integration of the water heating, space heating, and cogeneration waste heat systems
- Compact, energy-efficient, non-CFC refrigerators
- Energy-efficient heat pump with ozone-friendly refrigerant
- Reflective roof coating

Site Planning/Landscaping

- Existing palm trees kept on site
- Permeable gravel alley and underground stormwater retention system will retain 95% of the site's stormwater runoff (and 100% of the entire block's alley runoff) to allow its gradual absorption into the groundwater
- Drought-tolerant plantings, including native plants and ground cover
- Drip irrigation system with seasonal adjustment
- Parking spaces located underneath building to reduce heat island effect

Resource Conservation

- Construction site waste recycling
- Recycling bin storage area
- Recycled-content carpeting

Indoor Environmental Quality

- Operable windows and transoms for natural cross-ventilation
- Natural daylighting through courtyard design and window placement
- Low-VOC paint, formaldehyde-free MDF for cabinetry, natural linoleum instead of vinyl flooring

Alternative Transportation Provisions

- Bicycle racks and storage area
- Parking spaces for tenant vanpool vehicles
- Under consideration: Alternative fuel dispensing station for two vehicles

FINANCING

All of the project's special energy measures, combined, cost approximately \$500,000. This added cost is being covered, roughly half and half, by the City of Santa Monica and the Regional Energy Efficiency Initiative. The REEI is a joint program of Southern California Edison, the California Energy Coalition, and the Cities of Irvine and Santa Monica. It uses public goods surcharges from utility bills to fund energy-efficiency demonstration projects in those two cities.

Because REEI funds energy *efficiency* features only, the City covered the cost of the energy generation systems (the photovoltaic panels and gas turbine generator). The Community Corporation of Santa Monica expects to receive a buy-down of almost \$65,000 from the California Energy Commission for the photovoltaic

system, which cost approximately \$220,000. And Southern California Gas company is providing a \$17,800 rebate on the \$57,000 natural-gas turbine and cogeneration system (cost includes contractor's prevailing wage for installation); the company will also be doing field testing on the unit to see how it performs. The system is expected to have a payback in fewer than ten years, and the project's efficiency measures should have a payback (and net monetary benefit) in fewer than five years.

The stormwater retention system was paid for by the City of Santa Monica's Public Works Department, as part of the department's program to capture stormwater at key sites within the city, in order to prevent urban pollutant runoff into the bay.

CHALLENGES

As Colorado Court is a demonstration project, it is not surprising that its designers and developers encountered some obstacles in the course of its development. One of the main lessons learned was that the project never could have been accomplished without commitment towards the project goals from all members of the team. The following are some of the challenges that they faced:

Construction Waste Recycling: A new City of Santa Monica construction waste recycling ordinance will take effect in the spring of 2001. Once services are in place to handle such recycling citywide and the practice becomes commonplace, it is expected that contractors and owners will actually save money by recycling construction waste and thereby diverting it from landfills. Colorado Court served as a demonstration project to prepare for this ordinance. Because construction waste recycling is not yet common, and because the site was too small to allow for easy on-site waste separation, the Community Corporation has had to pay a premium (an estimated \$10,000) from its contingency funds to have the site's construction waste recycled.

Flooring: The architects would have preferred to have polished concrete floors with throw rugs in the apartments, rather than carpeting, because hard-surface flooring does not create the health problems that carpeting can, and because it would have saved money. However, it is common practice to include carpeting in affordable housing units, due to perceptions of comfort and to the extra soundproofing that carpeting provides. The architects also suggested natural linoleum flooring in lieu of synthetic vinyl flooring in bathroom and kitchen areas. At first, the higher cost of linoleum was considered prohibitive (even though linoleum is much more durable than vinyl flooring and therefore has a lower cost over its lifetime). In the end, the CCSM was able to negotiate a lower price for the linoleum, because they purchased it and the carpet from the same manufacturer.

Certified Wood: The original intent was to use wood from certified sustainably-harvested forests for framing. However, because the supply of certified wood was low during the course of the project, its price was prohibitively high.

Concrete: Cement used in this project will only contain up to 10% flyash. Flyash is a waste product from coal-burning power plants and trapping it in cement is a good way to use the waste material while also strengthening the concrete. The architects would have preferred to use cement with a higher flyash content. However, the added curing time required for higher flyash-content cement would have delayed the project, which would have made it more costly.

Equipment Downsizing: It took some time to convince the mechanical engineers to downsize the mechanical/electrical/plumbing equipment (hydronic radiators, piping, water pumps, and heat pump). But once the energy efficiency features were incorporated into the load analysis, downsizing and system integration were deemed feasible.

Tax Credits for Affordable Housing: The Colorado Court project was not selected for the highly competitive tax credits for low-income housing under the 2000 criteria. However, the new 2001 criteria issue points for energy efficiency. Had these criteria been in place last year, the project would have been more competitive.

Energy Generation Regulation: The architects, energy consultants, and CCSM have taken a creative and aggressive approach in incorporating the on-site, distributed power generation technologies into the project. Project team members have been involved in extensive coordination with state government officials. The most significant regulatory challenge they have faced concerns electrical net metering rules. Net metering means that when customers generate more electricity than they consume, the electricity can flow back into the grid and the customer's meter will run backward. The customer is credited for up to 100% of their net generation of electricity. Until recently, the state only allowed for the net metering of systems rated at a maximum of 10 kW of renewable power; the Colorado Court PV system can generate up to 30 kW of electricity. The City encouraged the State Assembly to adopt new legislation to accommodate larger systems. Midway through the construction of Colorado Court, the legislation was passed, allowing for net metering of systems rated up to 1 MW (1,000 kW). However, this will not be applicable to Colorado Court because of the way that Southern California Edison interpreted a Public Utilities Commission ruling that seemingly precludes buildings with more than one source of on-site power generation from net metering. This means that the project cannot reap the full benefits of having both the photovoltaic panels and the gas turbine.

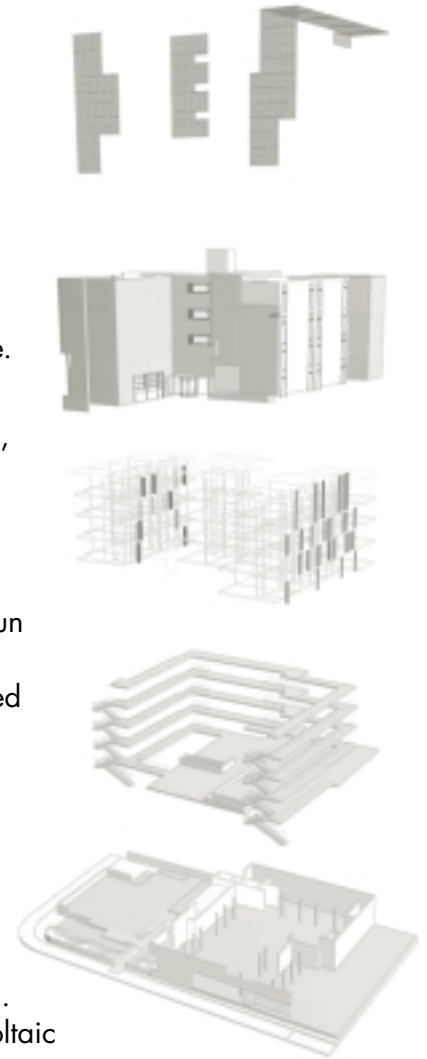

CONTACTS

- **Pugh Scarpa Kodama**
Architects, 310-828-2996, psk@pugh-scarpa.com
- **Helios International, Inc.**
Energy Consultant: Dr. John Ingersoll, 818-884-8782
- **City of Santa Monica—Housing and Redevelopment Division**
Project Manager: Jim Kemper, 310-434-2647
- **City of Santa Monica—Environmental Programs Division**
Energy and Green Building Coordinator: Susan Munves, 310-458-8229
- **Community Corporation of Santa Monica**
Project Manager: Robin Raida, 310-394-8487 x118





GLOBAL GREEN USA CASE STUDY



Site Planning · Alternative Transportation · Energy Efficiency · Renewable Energy · Resource Conservation · Resident Health

Nueva Vista Family Housing

131-136 LEIBRANDT STREET
SANTA CRUZ, CALIFORNIA

Nueva Vista is a cutting-edge example of how a dedicated affordable housing developer can incorporate many green features into a project while working within a limited budget. A 48-unit urban infill project just steps from the Santa Cruz Beach Boardwalk, Nueva Vista reduces car trips by including a child care facility and a city community center on-site, improves the health of residents by using a variety of non-toxic finishes, and lowers operating costs by incorporating solar electricity and other energy efficient measures.

Nueva Vista grew out of a lengthy organizing and community design effort in conjunction with the project's very low and low-income residents who work in the county's tourism and agricultural sectors, and the green aspects of the project helped build political support from the Santa Cruz City Council. The example set by Nueva Vista was instrumental in leading the developer, Mercy Housing California, one of the state's largest developers of affordable housing, to establish green building guidelines for all its future building projects.

PROJECT INFORMATION

Project Size:

Two buildings, 64,802 s.f. total, 48 units with child care facility and community center

Construction Cost:

\$10 million (\$154/s.f.)

Completion Date:

November 2003

Owner/Developer:

Mercy Housing California

Architect:

Van Meter Williams Pollack

Mechanical/Electrical Engineer:

MCT Engineers

General Contractor:

Devcon Construction

Energy Consultant:

Farber Energy Design

Solar Consultant:

EcoEnergies, Inc.

Financial Consultant:

Community Economics

GREEN FEATURES

Nueva Vista was conceived as a green project from the start, an aspect that greatly contributed to its overall success. Both green design and affordable housing experience were used as key criteria in the selection of the design team. The developer also identified potential funding resources early on, taking particular advantage of changes to the allocation criteria for affordable housing tax credits in California that support sustainable design. Because of this upfront commitment and the realization that some extra resources were potentially available, many of the project's green features were not "add-ons" but integral to the design.

In the early design phases, attention was paid to building orientation so that the units could maximize the benefits of both sunlight and ocean breezes. Window-shading and

through units enabled the project to eliminate air conditioning and rely purely on natural ventilation to cool the building. Hard-coat glazing allows for heat gain during the cold winter months but still reflects harmful ultraviolet rays.

Energy efficiency was also stressed. Gas-powered hot water heaters do double duty by providing space heating in each apartment. (See Diagram) Highly efficient refrigerators were also specified for each unit. As a result of these and other measures, the entire complex is expected to exceed the standards of the California Title 24 Energy Code by at least 15%. With all units individually metered for both gas and electricity, much of the energy savings will flow directly to the residents. Meanwhile, the owner will save approximately \$5,000 per year in operating costs by directing the

(Continued on Next Page)

(Green Features Continued)

electricity generated by the 20 kW solar system to the common areas, including all exterior and interior common area lighting, the irrigation system, the elevator, and office machines, computers and appliances in the community room.

Researching, identifying and specifying green building materials, particularly those which have a positive effect on the health of residents, was a major challenge. The architect worked with their own appropriate materials checklist to set design criteria and explore cost implications. Later, a green design charrette, conducted by Global Green USA as construction documents were being prepared, helped narrow the choices and identify creative ways to pursue green building objectives. For example, a system of “bid alternates” was devised so that the contractor would obtain cost information for green materials that were not included in the original budget. This enabled Mercy Housing the flexibility to choose and prioritize which features could affordably be incorporated into the development.

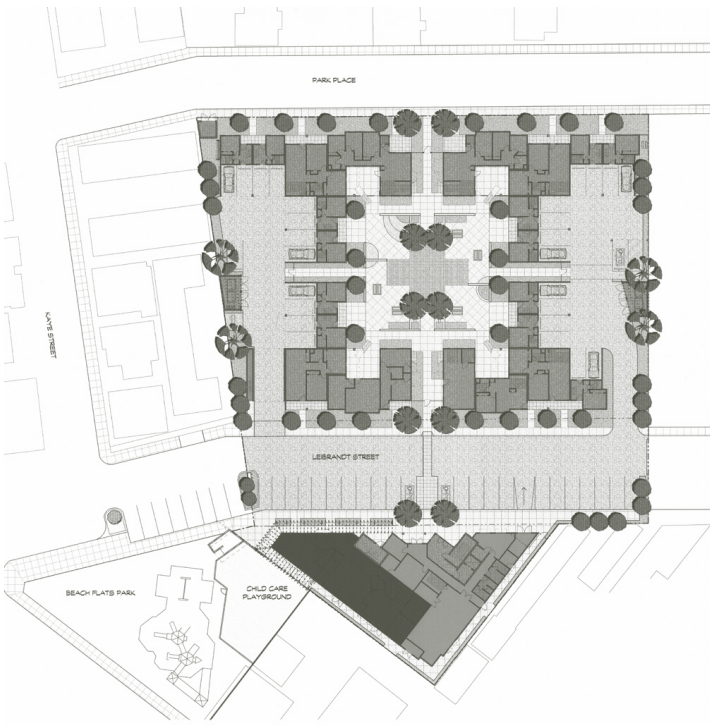

The site plan orients the buildings to maximize the benefits of both sunlight and ocean breezes

Site Planning/Alternative Transportation

- Highly efficient drip irrigation system with scheduled timing
- Native, drought-resistant plants with low water needs
- Reduced parking
- Ample bicycle storage

Energy Efficiency and Renewable Energy

- Individual electrical and gas meters to promote energy conservation
- Hot water heaters also power space heaters (see illustration)
- Energy Star™ appliances
- All fluorescent lighting
- Double paned windows with low-E, hard-coat glazing
- No mechanical cooling
- 10 kW AC solar electric system installed on each building
- 140 roof-mounted solar panels generate approximately 35,000 kilowatt-hours per year
- Digital display of solar generation in each building, displaying \$350/month in operating cost savings

Resource Conservation

- Sustainably harvested plywood, FSC-Certified
- Permanent flow restrictors reduce water use in sinks by two-thirds
- Natural linoleum flooring in kitchens and bathrooms
- Recyclable carpet with high level of recycled content
- Construction waste recycling

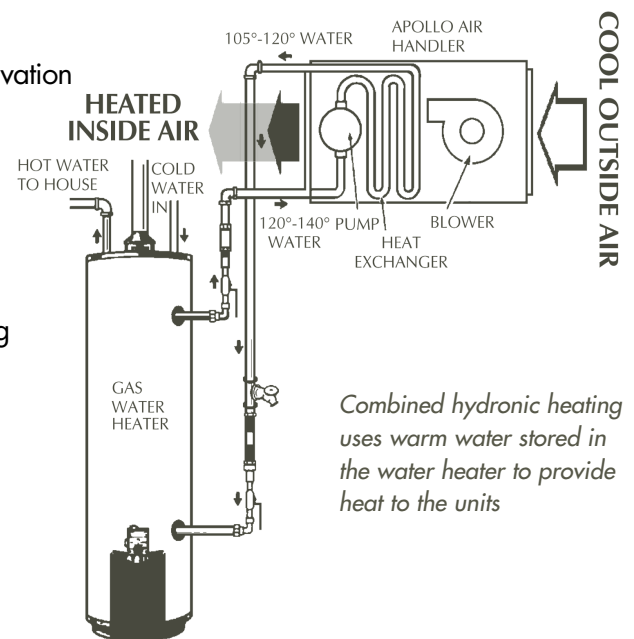

Resident Health

- Fully vented cooking
- High-capacity bathroom fans to reduce spread of mold
- Formaldehyde-free batt insulation
- No-VOC paint
- Formaldehyde-free counter substrates
- Arsenic-free sill plates

FINANCING

Like most affordable housing projects, a variety of public and private sources were used to build the project. These sources included the federal and state tax credit programs for affordable housing, the Federal Home Loan Bank's Affordable Housing Program, the City of Santa Cruz and its Redevelopment Agency, a conventional mortgage from Citibank, and a grant from the David and Lucille Packard Foundation to assist with the costs of the child care facility.

Nueva Vista also benefited from a wide variety of special funds dedicated to green building. The project was awarded tax credits partially due to extra points it was granted in the tax credit allocation scoring system for besting Title 24 energy efficiency standards by 15% and for installing energy efficient appliances, fluorescent light fixtures, and water-efficient landscaping. The total cost of the solar electricity system, \$211,000, was more than offset by special funds available for installing renewable energy systems, including federal and state solar tax credits bought by the project's tax credit investor, AEGON Community Investments.

Green-specific financing included:

| Funding Source | Building Component | Amount |
|---|--|--------------------------|
| PG&E Comfort Home Program | <i>Energy Efficient Building Components</i> | \$ 11,500 |
| Tax Credit Basis Boost (5%) | <i>Solar Electricity Generating System</i> | \$ 289,000 |
| Federal/State Solar Tax Credits | <i>Solar Electricity Generating System</i> | \$ 21,000 (estimated) |
| California Energy Commission Energy Renewables Rebate Program | <i>Solar Electricity Generating System</i> | \$ 98,000 |
| California Public Utilities Commission LiteWash Program | <i>Energy Star™ washers and dryers</i> | \$ 2,100 |
| Packard Foundation | <i>Non-toxic and other high quality building materials</i> | \$ 20,000 |

WHY BUILD GREEN?

Buildings have a profound impact on our health, economy and natural environment, using large amounts of energy and materials, while accounting for 30% of all waste in landfills. By building green, developers can mitigate these regional and global impacts, while saving money for themselves and their tenants.

Benefits to tenants and the building owner include:

- Reduced energy bills
- Reduced water bills
- Reduced maintenance costs
- Better indoor air quality

Regional benefits include:

- Stormwater retention
- Better waste management
- Less pressure on aquifers and other fresh water resources

Global benefits include:

- Forest protection
- Better air quality and reduced emissions
- Slowing down climate change
- Growth in the market for recycled materials

In affordable housing developments, green building can alleviate certain problems particular to low-income residents. The improved indoor air quality resulting from a more rigorous selection of non-toxic building materials helps to lower asthma rates, which are directly correlated to income levels. Meanwhile, lower utility bills have the greatest value to low-income residents, who on average pay 25% of their post-rent income for basic services.

CHALLENGES

Even with a committed developer, experienced design team, and a host of extra funds available to the project, Nueva Vista faced a number of challenges in the process of creating a successful green project.

- ❑ **Construction Management:** Initially the contractor had some difficulty adjusting to the different “green” specifications being considered by the design team and was reluctant to accept changes to standard construction practice. After much discussion, a process familiar to the contractor was devised whereby the contractor was asked to price certain green materials as bid alternates. This required the contractor to make an up-front commitment to providing the materials at a specified cost and allowed the developer to calculate which of various options fit within the budget. While this system of bid alternates was crucial to moving the project forward, it does have some drawbacks. The shortcomings of this approach include: the need for the design team to do a great deal of research to develop the set of alternative specs; the potential that green building materials will forever be seen by contractors as an “alternate” rather than standard practice; and the possibility that many green features will be labeled as additional cost items and ultimately be rejected by a less committed developer.
- ❑ **Carpet Recycling:** In affordable housing developments, carpeting is typically changed every 5 to 7 years. This frequent rate of replacement generates thousands of pounds of landfill waste, an issue of particular concern in Santa Cruz county where existing landfills will reach capacity within 15 years. As a result, attention focused on specifying carpet that was made of recycled material and is recyclable as well. While many carpet manufacturers claim that their carpets are recyclable – with some even offering “take-back” programs – the actual infrastructure for carpet recycling is weak. For example, one option for recyclable carpet that was considered would have required the owner to cut the old carpet into pallet-size pieces and pay to have it delivered to another county. Another manufacturer agreed to take back the carpet after removal but could not guarantee that it would actually be recycled, indicating that it might be incinerated instead. Eventually the decision was made to specify carpet with recycled content and made from nylon-6, a material with recyclable properties, with the hope that the industry and recycling infrastructure will evolve significantly over the next several years.
- ❑ **Kitchen and Bathroom Flooring:** Great effort was put into eliminating vinyl flooring – which is generally not recyclable and generates harmful pollutants when manufactured – by using natural linoleum in both the kitchen and bath. While linoleum had a higher upfront cost (\$5.00/sf versus \$3.50/sf for sheet vinyl), it should last 40 years, compared to only 7 to 10 years for sheet vinyl, thus significantly lowering operating costs over time. Nevertheless, there continues to be concern about the potential for moisture-related problems with the linoleum in the bathroom. Great care was put into installing the linoleum properly, while moisture build-up is minimized by providing high-capacity fans with no manual override (as opposed to automatic humidistat controls) in the bathrooms. Tenants will also be given material explaining the environmental benefits of linoleum versus vinyl and the need for proper maintenance.
- ❑ **Water Metering:** To promote conservation, the developer investigated providing individual water meters to the units in addition to the individual electricity and gas meters. This proved to be more difficult than expected, as each meter would have required a separate and costly hook-up fee. A system of sub-metering, whereby individual flow meters are installed and residents are billed separately by a third party, could not be set up within the time dictated by the construction schedule but remains a promising option.

CONTACTS

- **Mercy Housing California**, *Owner/Developer*
Project Manager: Elisabeth Vogel, 831-471-1910, evogel@mercyhousing.org
- **Van Meter Williams Pollack**, *Architect*
Architect: Fred Pollack, 415-974-5352, fred@vmwp.com
- **Global Green USA**, *Green Building Technical Assistance*
Program Director: Walker Wells, 310-394-7700, wwells@globalgreen.org
- **EcoEnergies**, *Solar Consultant*
Sales Manager: Mike Arenson, 831-427-9070, marenson@ecoenergies.com





GLOBAL GREEN USA CASE STUDY



On-Site Energy Generation · Energy Efficiency · Landscaping/Site Planning · Resource Conservation · Indoor Environmental Quality

20th St. APARTMENTS

1925 & 1933 20th Street, Santa Monica, California

Santa Monica's 20th Street Apartments serve as a pioneering example of an energy-efficient rehabilitation of a low-income housing development. The City and the Community Corporation of Santa Monica expect that future housing rehabilitation projects will incorporate many of the energy efficiency features demonstrated in this project, and will probably include an even broader array of environmental features.

PROJECT INFORMATION

Project Size:

30,000 SF, 2 buildings, 34 one- and two-bedroom units

Construction cost:

\$635,000

Completion date:

Spring 2001

Owner/Developer:

Community Corp. of Santa Monica

Architect:

Ralph Mechur Architects

Energy Consultant:

Syska & Hennessey

Contractor:

The Best Merit Co.

GREEN FEATURES

The 20th Street Apartments, built in the late 1960s, is typical of apartment construction in Santa Monica during this period. The building included an inefficient radiant ceiling heating system, limited insulation, and single-glass glazing on windows and sliding doors.

The City saw the need to replace the radiant heating system as an opportunity to undertake a more extensive energy retrofit. The City hired Syska & Hennessey, engineering consultants, to conduct an energy audit and efficiency feasibility study. Using the TRACE computer energy modeling software for the assessment, they prepared an Energy Efficiency Alternatives Report, which recommended various energy efficiency options, based on criteria such as the financial payback period and funding potential. The energy efficiency upgrades that have been incorporated into the project are as follows:

- Solar-assisted hot water heating system repaired
- Refrigerators in some units replaced with Energy Star refrigerators
- R-30 attic insulation added
- Wall insulation added
- Windows and sliding glass doors replaced with dual-glazed glass
- Compact fluorescent lightbulbs provided for residents
- Thermostats with night setbacks provided
- Skylights (for natural lighting) added to stairwells

The consultants estimate that the upgrades will reduce the building's electric energy usage by 39% and natural gas usage by 22%, resulting in savings of more than \$10,000 per year. The project also includes environmental features including:

- Recycled plastic Trex lumber for the patio fences
- Recycled rubber mat for the playground
- Low-flow showerheads
- Drought-tolerant plantings

FINANCING

This project's energy efficiency upgrades added approximately \$106,000 to the project cost. The upgrades were funded by the City of Santa Monica and by the Regional Energy Efficiency Initiative. The REEI is a joint program of Southern California Edison, the California Energy Coalition, and the Cities of Irvine and Santa Monica. It provides funding for energy-efficiency demonstration projects in those two cities. The Energy Star refrigerators and the compact fluorescent lightbulbs were provided by Southern California Edison. Edison will be monitoring the energy savings afforded by the new refrigerators.

CHALLENGES

Limited Scope of Rehabilitation Projects: It is generally easier to incorporate green approaches into a new building design than into a renovation project. Because the siting, form, and window location were all predetermined at 20th Street, the majority of the work focused on upgrading existing systems. Furthermore, because rehabilitation projects often involve selective rehab work (replacement of materials and finishes in only a few units), such projects do not lend themselves to high-volume economies of scale for procuring alternative materials.

Standards for Green Building: The Community Corporation of Santa Monica (CCSM) has not yet integrated the City of Santa Monica's Green Building Design and Construction Guidelines into the internal standards used by CCSM project managers and facilities managers. However, CCSM's Minimum Standards for Rehabilitation Projects currently do include several items related to green building. There are: installation of setback thermostats, upgrading to R-19 insulation throughout the building, installation of fluorescent fixtures in kitchens and bathrooms, prohibiting the use of particleboard for kitchen cabinets, and requiring contractors to obtain an alternate cost for recycled carpeting, and. These standards are included in all rehab bid packages and implemented at the discretion of the individual project managers. In the 20th Street project, plywood was used instead of particleboard for kitchen cabinets, which greatly reduces but does not eliminate the presence of formaldehyde. In the future, CCSM is looking into specifying a no-formaldehyde fiberboard such as Medite II or Allgreen in future projects. Recycled-content carpeting was not used in this project due to cost, but is also being explored for future projects. CCSM is also researching prices and suppliers of no-VOC paints and natural linoleum flooring. Community Corporation anticipates that more green features will be incorporated into the Standards for Rehabilitation Projects as more products and materials are tested in upcoming projects.

Familiarity with Green Materials and Approaches: Project managers involved with the project expressed the importance of all project team members being familiar with green techniques, technologies, and materials. One of the major reasons that many green materials were not incorporated into this project is that the contractors, specifiers, and project managers were unfamiliar with the materials, their performance installation and maintenance, where they could be purchased.

Added Costs: Green components have a wide variation in costs. Some are less expensive than or equal to conventional methods and materials. Others have higher up-front costs. Sometimes higher initial costs can be offset by long-term paybacks. In the 20th Street project, much of the energy efficiency upgrades were offset by REEI funds. More extensive upgrades could have been completed if additional funds were available. For example the energy consultants found that it was viable to spend approximately \$4,000 to refurbish the old solar water heating system. However, adding new photovoltaic panels was not deemed to be financially viable. Costs for green items should decrease over time, however, as green features become more standardized, the combination of market competition, increased availability, and opportunities for discounted bulk bring prices down.

CONTACT

- **City of Santa Monica—Housing and Redevelopment Division**

Project Manager: Dora Rosiles Kochen, 310-458-2232, dora-rosiles@santa-monica.org

- **Community Corporation of Santa Monica**

Project Manager: Nicole Smith, 310-394-8487 x115, nicole@communitycorp.org

Facilities Manager: Miguel Ceballos, 310-394-8487 x127, mceballos@community.org

GLOBAL GREEN USA
BUILDING BLOCKS





GLOBAL GREEN USA CASE STUDY

GREENING AFFORDABLE HOUSING INITIATIVE



Site Planning · Alternative Transportation · Energy Efficiency · Renewable Energy · Resource Conservation · Resident Health

FIRST COMMUNITY HOUSING 2 NORTH SECOND STREET SAN JOSE, CALIFORNIA

www.FirstHousing.org

First Community Housing, a San Jose, California-based non-profit housing developer is demonstrating how an organization can better serve the housing needs of low-income families by making green building a core part of its overall mission. By designing all its buildings to be energy efficient and by specifying non-toxic building materials, First Community Housing ensures that its tenants benefit from lower utility bills and healthier living environments. Furthermore, First Community Housing encourages the use of alternative transportation by locating all its projects along mass transit routes and providing free monthly transit passes.

Since 1986, First Community Housing has built nearly 800 units of affordable housing, putting the long-term savings generated by energy efficient design and highly durable materials into new developments and into the maintenance of existing projects. By demonstrating that green building techniques can both lower a developer's costs over the long-term and increase overall affordability for tenants, First Community Housing has gained a stellar reputation among the two entities that typically can make or break an affordable housing project - financial institutions and local government officials.

RECENT MAJOR PROJECTS

| Project | Units | Construction Cost |
|--|-----------------------------------|-------------------|
| Craig Gardens Senior Apts (2002) | 90 (1 bedrooms units) | \$123/SF |
| Murphy Ranch - First Phase (2003) | 62 (2, 3, 4 bedroom townhomes) | \$134/SF |
| Betty Ann Gardens (2003) | 76 (1, 2, 3, and 4 bedroom units) | \$145/SF |
| Paseo Studios (2003) | 98 (Furnished SRO) | \$161/SF |

Four older properties have had photovoltaic solar systems installed to cover all common area electrical needs. The swimming pool at the 246-unit Los Esteros family development was converted to solar heating, a retrofit that had a four-year payback and extended the swimming "season" by two months.

THE MAKING OF A GREEN DEVELOPER

Founded in 1986, First Community Housing's transformation into a green affordable housing developer began in 2000 when the FCH Board of Directors determined that FCH should refocus on being a development-driven firm whose sole mission was to build and manage high-quality affordable housing in the Silicon Valley area of California. During this transformation, staff resources were concentrated into areas most closely aligned with the development process - architectural design, construction management, development finance and asset management. With this expertise present within the organization, new Executive Director Jeff Oberdorfer,

an architect with experience in both the private and public sectors, set about to develop green performance and program standards for all of First Community Housing's developments.

These Minimum Standards for Finishes, Systems and Appliances are grouped by construction specification codes and set minimum green requirements in areas such as site work, structural framing, mechanical systems, interior finishes, appliances and lighting. Performance targets are also set, including exceeding the California Title 24 Energy Code by 15%, recycling 75% of

(Continued on Next Page)

Betty Ann Gardens

76 ONE TO FOUR BEDROOM UNITS
SAN JOSE, CALIFORNIA

GREEN FEATURES



- Rehabilitation of adjacent transit stop: free mass transit passes for all residents
- Riparian restoration and protection
- Existing heritage trees incorporated into site plan
- Low-flow water fixtures
- Exceeds California Title 24 Energy Code by 25%
- Double-glazed windows and sliding doors
- All gas appliances
- Hydronic heating and cooling
- All fluorescent light fixtures
- Natural linoleum and recycled-content carpet floors
- Hardiboard fiber-cement siding
- Recycled-content interior trim and baseboard
- Engineered structural lumber
- "Eco-Star" recycled content roof on Community Building
- Sustainably harvested teak benches and lobby furniture
- Wheat composite office furniture
- 99% recyclable office chairs
- Formaldehyde-free counter substrates
- No VOC and formaldehyde-free cabinets with water-based varnish
- Formaldehyde-free batt insulation
- Low VOC Paint

(Continued from previous page)

construction waste, and powering 100% common area lighting with renewable energy. Many of these requirements coincide with the green incentives in the California tax credit criteria that Global Green USA helped design. (See summaries of Betty Ann Gardens, Murphy Ranch, and Paseo Studios for examples of how these standards have been applied in recent FCH projects.)

To ensure that the green practices are implemented, First Community Housing develops all its projects using a Design/Build system with a pre-selected General Contractor. In this process, the General Contractor and all the major sub-contractors, are involved with FCH and the project architect from schematic design onward. This avoids a "low-bid" system that could potentially eliminate some green building features from a project. FCH has also established a reputation for holding fast to its green building materials specifications, which enables it to negotiate substantial discounts on materials from product representatives who know that the specified materials will actually be purchased.

Even with these discounts, however, some of the green materials and systems used in First Community's projects have higher first costs compared to standard construction practice. From a life-cycle perspective, though, these options add long-term value to the projects. Because First Community is required to own its properties for 40 years or more, items with a long-term payback are justified. Another budgeting strategy is to use contingency funds that remain as a project nears completion for an established "wish list" of green upgrades on finish materials.

First Community Housing's reputation as an award-winning developer and green builder has helped negate the myth that affordable housing will create a negative impact on its "host" neighborhood and gives it a competitive edge when negotiating with local governments over potential future projects. As lenders start to evaluate the durability and long-term savings provided by green building materials such as linoleum, formaldehyde-free cabinets and photovoltaic panels, FCH will be well placed to take advantage of lower interest costs and lower replacement reserve requirements.

FIRST COMMUNITY HOUSING Minimum Standards for Finishes, Systems and Appliances STANDARDS FOR ARCHITECTS

INTRODUCTION. These performance standards are for all First Community Housing developments. Since they are not project-specific, they may be modified with written consent from FCH to suit the specific needs of each development. The goal is to utilize as many energy efficient systems, sustainable features and green building materials as budget allows. At the initiation of Concept Design, FCH will determine whether to pursue LEED Certification. The A/E Team should use LEED Reference Package Version L-1 as a General Guide.

DIVISION 1 - GENERAL REQUIREMENTS

1. **Project Construction Site:** Graphics and Design provided by Owner for horizontal and plywood sign.
2. **Job Site Waste:** Recycle minimum 75% of inert, unpainted dimensional lumber, metal, plastics and cardboard.
3. **LEED Certification:** A/E Contract and GC Design/Build Contract will incorporate LEED Certification where appropriate.

DIVISION 2 - SITEWORK (Refer to LEED Credit 7.1—Heat Island Effect)

1. **Grass and Surface:** Investigate the use of permeable surfaces wherever feasible. Asphalt Paving to be 2-1/2" over 6" AB. Use Slurry Seal or "Open Coat" but not Fog Seal.
2. **Substrate:** Per City Standards. 4" over lime treated soil, or 4" rock over compacted soil.
3. **Concrete Finishes:** Standard Broom Finish Grey (no colored paving or stamped concrete).
4. **General Lighting:** All light photometrics and balling by a FCH approved Lighting Consultant, under contract with the Executive Architect.
5. **Ballast Lighting:** Minimize, and use building mounted light fixtures. Fixture approval by FCH. All site lighting near perimeter of site to incorporate cut off shields.

The overall goal of FCH's design standards is "to utilize as many energy efficient systems, sustainable features and green building materials as budget allows."

FAQ: HOW TO BECOME A GREEN AFFORDABLE HOUSING DEVELOPER

Q: What is the first step towards becoming a green affordable housing developer?

A: Create organizational green design standards. Many green strategies and specifications can be common to different types of developments. Standardization works particularly well with interior and exterior finishes, roofing and insulation materials, flooring, appliances, and furnishings. Standardizing building materials also allows for the negotiation of volume discounts from suppliers.

Q: But every project is different. Are green design standards flexible enough?

A: Standardizing frees up time to focus on the individual challenges of each project. By standardizing certain elements, design costs can be concentrated on evaluating options for items that vary by project, including site preparation, building orientation, mechanical systems, and the type and scope of renewable energy systems.

Q: I am working on a limited budget and people always say that green building costs more. How can I get the right advice on cost-effective designs and materials?

A: Work with architects and contractors experienced in green building. Green building expertise is uneven across the design and building industry and for some professionals new to green techniques and strategies, the learning curve can be steep. By working with individuals and firms with prior green building experience – or at a minimum with those firms eager to do research and learn – developers can share the burden of paying attention to the right details while avoiding unnecessary and potentially costly experimentation.

Q: I've got some basic green design standards. How can I ensure that they are being met?

A: Do construction management in-house. In-house construction management allows the developer to both set the green standards and ensure that they are implemented. A developer who has strong construction management expertise in-house is at a distinct advantage when trying to green its projects. Without active design document and construction oversight, many building professionals, particularly subcontractors, revert to traditional (and wasteful) techniques and specifications.

Q: What can I do to realize the full benefits of being a green affordable housing developer?

A: Track and measure performance. Green building brings a number of benefits to developers and residents, including lower operating and maintenance costs, improved resident health, and less environmental impact on the surrounding community. But, as of yet, these benefits are difficult to fully capture in terms of lower financing costs or increased political support for affordable housing. Measuring performance and demonstrating actual improvements or savings in a clear and concise manner will help build credibility among financiers and government officials and ensure support for future green projects.

Murphy Ranch 62 FAMILY TOWNHOMES, MORGAN HILL, CALIFORNIA

GREEN FEATURES

- Free mass transit passes for all residents
- Low-flow water fixtures
- Exceeds California Title 24 Energy Code by 27%
- Solar electricity generation for all common areas
- Solar-heated swimming pool
- Hydronic heating and cooling
- Blown-in cellulose insulation
- Double-glazed windows and sliding doors
- All gas appliances
- All fluorescent light fixtures
- Recycled-content carpet floors
- Hardiboard fiber-cement siding
- Recycled-content interior trim and baseboard
- Engineered structural lumber
- Sustainably harvested teak pool and recreation area furniture



- Wheat composite office furniture
- 99% recyclable office chairs
- Formaldehyde-free batt insulation
- Low-VOC Paint

CHALLENGES

Via its Minimum Standards for Finishes, Systems and Appliances, First Community Housing now has a base set of green criteria that is incorporated into the planning and design of each of its projects. But this document is constantly evolving. Looking forward, FCH hopes to address a number of other environmental challenges.

- ❑ **Renewable Energy:** First Community Housing has so far used solar generated electricity to power site lighting and common areas and solar hot water to heat swimming pools and pool shower facilities. The developer would like to expand the use of solar electricity to meet at least part of the demand load of the units. FCH is considering using spaces like carports as generating facilities, with the long-term goal of selling electricity back to the local utility.
- ❑ **Sustainable Sites:** Most affordable housing developments are dense urban infill projects. Constrained site conditions make certain sustainable strategies such as stormwater management, permeable paving and natural greywater treatment challenging to implement. FCH sees this as a major area for innovation, perhaps by linking several projects in close proximity or combining future projects with larger community land preservation and smart growth strategies.
- ❑ **Carpet Recycling:** In affordable housing developments, carpeting is typically changed every 5 to 7 years. This frequent rate of replacement generates tons of landfill waste annually. FCH uses carpet tiles that have a high level of recycled content. While the carpet manufacturer guarantees that used carpet will not end up in landfill – by recycling, upcycling, or downcycling – the cost of shipping the used carpet is a potential barrier.
- ❑ **Indoor Air Quality:** Ensuring high quality air circulation and the proper number of air changes without oversizing the mechanical system or installing noisy components is a major challenge. This is particularly the case in kitchens and bathrooms, where moisture and other contaminants are present in high concentrations. FCH has been able to overcome these challenges on a project-by-project basis but would like to find ways to standardize this building element.

CONTACTS

- **First Community Housing, Developer**
Executive Director: Jeff Oberdorfer, AIA, 408-291-8650, JeffO@FirstHousing.org
- **Global Green USA, Green Building Technical Assistance**
Program Director: Walker Wells, 310-394-7700, wwells@globalgreen.org

Paseo Studios

98 SRO UNITS
SAN JOSE, CALIFORNIA

GREEN FEATURES

- Adjacent to transit and shopping: free mass transit passes for all residents
- Low-flow water fixtures
- Double-glazed windows and sliding doors
- "Cool Roof" (white finish topping on built up roof)
- All fluorescent light fixtures
- Natural linoleum and recycled content carpet
- Recycled-content interior trim and baseboard
- Engineered structural lumber
- Recycled-content metal siding and balcony slats
- Sustainably harvested maple beds
- Sustainably harvested teak courtyard furniture
- Wheat composite office furniture
- 99% recyclable office chairs
- No VOC and formaldehyde-free cabinets with water-based varnish
- Formaldehyde-free counter substrates
- Formaldehyde-free batt insulation
- Low VOC Paint



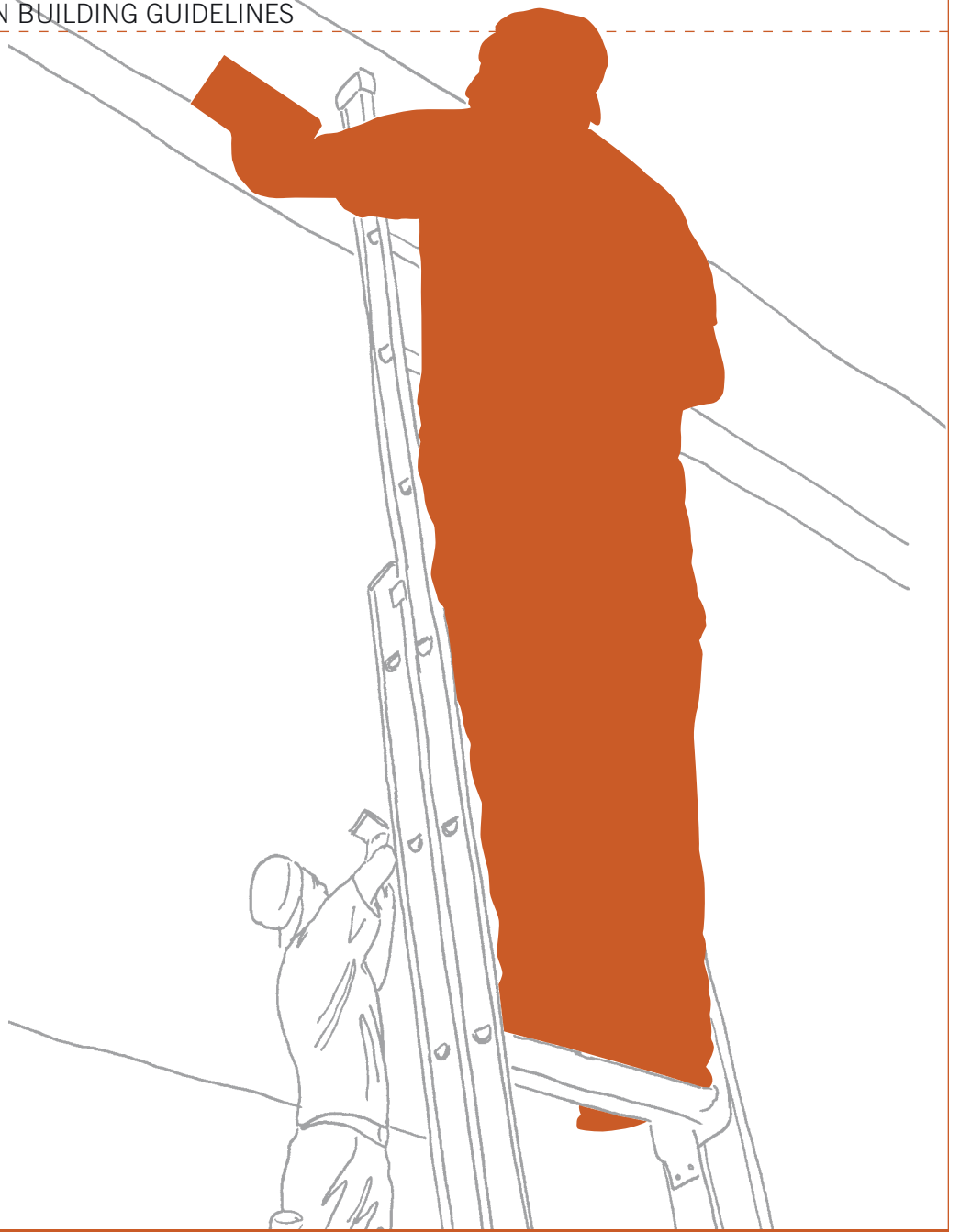

RESOURCES

RESOURCES

Fold TAB here

Tuck here

RESOURCES



MATERIALS DATABASE

ACWMA maintains an online database of building materials that correspond with our Multifamily Green Building Guidelines. You can access it at:

www.multifamilygreen.org

The Materials Database is searchable by product categories, product names, and measure numbers. It is constantly being revised based on local availability of products and the development of new materials. A PDF file of multifamily green building products organized by measure number is also available at www.multifamilygreen.org.

Listing in the Materials Database should not be construed as a recommendation or endorsement by the Alameda County Waste Management Authority or the Alameda County Source Reduction and Recycling Board, which is providing the information as a public service to promote the use of sustainable building materials and reduce the amount of materials landfilled.

OTHER ACWMA RESOURCES

The following documents referenced in these guidelines are also available at www.multifamilygreen.org:

Construction & Demolition / Green Building

- » Construction and demolition (C&D) waste management model ordinance
- » List of cities that have C&D ordinances
- » Section 01505: C&D Waste Management
- » *Builders' Guide to Reuse and Recycling*
- » Fact Sheet on Financial Incentives for Photovoltaics in Multifamily Housing

Landscaping

- » *Bay-Friendly Landscaping Guidelines*

Waste Management & Recycling

- » *Alameda County Recycling Guide*
- » Information on recycling and composting

Recycled Products

- » Information about buying recycled products
- » Fact Sheet with Pointers on Using Recycled-Content Plastic Lumber
- » Fact Sheet on Recycled Content Park and Recreation Products in Alameda County
- » *Guide to Recycled Content Janitorial Paper Products in Alameda County*

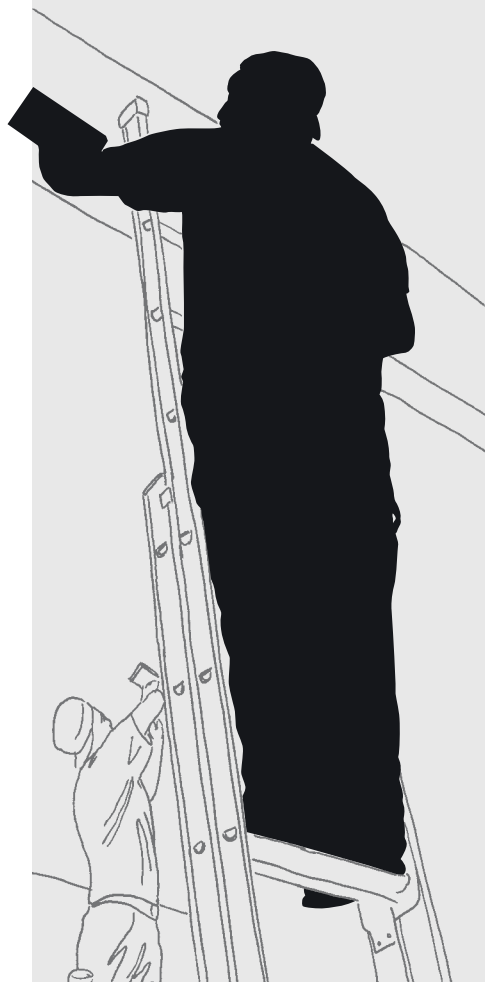



User Evaluation Form

Please take a few moments to help us improve our materials.

Multifamily Green Building Guidelines...

... is well organized.

... is easy to understand.

... provides practical recommendations.

... has helped me to implement green building strategies.

... is useful enough to recommend to others.

| | Agree Strongly | Agree | Neutral | Disagree | Disagree Strongly |
|---|----------------|-------|---------|----------|-------------------|
| ... is well organized. | | | | | |
| ... is easy to understand. | | | | | |
| ... provides practical recommendations. | | | | | |
| ... has helped me to implement green building strategies. | | | | | |
| ... is useful enough to recommend to others. | | | | | |

What is your profession?

- Project Manager Architect Contractor
 City Staff Elected Official Other

How will you use this guide?

(check all boxes that apply)

- To educate myself. To educate others in my company.
 To educate clients. To educate colleagues.
 Policy development. Land use planning.

If you would like to be included on a mailing list for information about Green Building workshops and other events, please provide your complete mailing address and/or email address:

Other feedback or corrections: (continue on back)

Please **mail** this form back to us at:
 ACWMA, Multifamily Green Building Guidelines
 777 Davis Street, Ste. 100, San Leandro, CA 94577
 or **fax** it to 510-614-1698

To order additional copies of the Multifamily Green Building Guidelines, or for a free **online** version, please visit www.multifamilygreen.org

Feedback (continued)

[Empty feedback area]