

City of Albany

DESIGN GUIDELINES FOR SINGLE-FAMILY RESIDENTIAL ADDITIONS, ACCESSORY DWELLING UNITS AND NEW HOMES



Community Development Department

1000 San Pablo Avenue

Albany, CA 94706

(510) 528-5760

www.albanyca.org



FINAL ADOPTED GUIDELINES

Albany City Council

2/20/2018

ACKNOWLEDGMENTS

Albany City Council

Michael Barnes
Peter Maass
Peggy McQuaid
Rochelle Nason
Nick Pilch

Planning and Zoning Commission

Megan Jennings
Chris Kent
Val Menotti
Doug Donaldson, Vice Chair
Erik Giesen-Fields, Chair
Susan Friedland, former Commissioner

Community Development Department Staff

Jeff Bond, Community Development Director
Anne Hersch, Planning Manager
Christopher Tan, Associate Planner

CONTENTS

INTRODUCTION

1. Background
2. Purposes and Goals of the Guidelines
3. Utilizing the Guidelines
4. Design Review by the Planning and Zoning Commission
5. Quality Architectural Plans

THE 7 PRINCIPLES

1 LANDSCAPE DESIGN

- The front yard area is the home's contribution to the community
- Pedestrian emphasis

2 OUTDOOR SPACE

- Rear Yard Decks
- Roof Decks
- Balconies
- Indoor/Outdoor Flow

3 ARCHITECTURAL DESIGN

- Front porches and covered entries are strongly encouraged
- Architectural relief is an important aesthetic element
- Trim and details give a house warmth and character
- Paint Color
- Building materials
- Window details

4 LIVABILITY

- Modernizing interior space for better function and long-term occupancy
- Interior Ceiling Heights
- Universal Design
- Expansion types

5 CONTEXT

- Compatibility with adjacent homes
- Privacy considerations

6 ACCESSORY DWELLING UNITS

- The City encourages the creation of Accessory Dwelling Units
- Accessory Dwelling Units should have a defined entrance/entry separate from the main dwelling

7 PARKING

- Garages and parking are important considerations on Albany's Small lots
- Electric Vehicle Charging Stations
- Garage Doors
- Driveway Materials

ARCHITECTURAL CHARACTER FROM 1910-1950

CONTEMPORARY DESIGN

BEFORE AND AFTER PHOTOS

EXCEPTIONAL DESIGN

INTRODUCTION

Background

Albany is the northernmost city in Alameda County and is physically defined by creeks on its northern (Cerrito Creek) and southern (Codornices Creek) borders. Land uses, building types, and densities are similar to those in the adjacent cities. The land area encompasses 1.79 square miles with a population of roughly 18,500 residents. There is a density of 10,368 persons per square mile making Albany one of the highest-density cities in the Bay Area. Most of Albany's neighborhoods are developed along a rectilinear street grid, although the grid shifts slightly in orientation in the eastern third of the City. There are roughly 25 north-south streets and fewer than ten major east-west streets, forming blocks that are generally 200 feet wide and 400 to 600 feet long. Most of this area was subdivided in the first three decades of the 20th Century, with rectangular lots of 25 to 50 feet in width and 100 feet in depth (2,500-5,000 sq. ft. lots).

The City's housing stock was largely built in the 1920's with smaller homes reflecting a diverse range of architectural styles. Architectural styles present in the City include Spanish Revival, Craftsman, Tudor, Minimal Traditional, and Modern/contemporary. Charles MacGregor was the predominant developer of the community in the late 1920s through the 1940s. His company built over 1,500 homes in the City and maintained their main offices on Solano Ave. The homes are often referred to as "MacGregors" and were built as two bedroom, one bathroom dwelling units, approximately 800 sq. ft. in area. Majority of Macgregor homes were constructed as split level, as seen in the photos below.



1. Purpose and Goals of the Guidelines

The Residential Design Guidelines were established to assist applicants, neighbors, staff, and commissioners in understanding and applying Albany's Planning and Zoning Code while also communicating the City's design goals through explanations and examples of high quality solutions. The intent of the Guidelines is to provide specific design principles that encourage thoughtful development, a cohesive building form, and a sense of community in an urban environment.

2. Design Review by the Planning & Zoning Commission

Albany Municipal Code Section 20.24.020 provides the development standards for all residential zoning districts, which include all setbacks, height, FAR, and other requirements. Compliance with the Code's development standards is mandatory.



The Guidelines are meant to enhance and not restrict architectural creativity in a city where there is no one dominant architectural style. It is acknowledged that there are a variety of budgets, needs and desires by residents which all need to be balanced to provide high quality homes that are a pleasure to live in as well as live among. Thoughtful application of the Guidelines and a sensitive design that is well detailed, using quality materials, reduces the potential for conflict. Applicants are highly encouraged to talk to neighbors about their development needs, options, and design proposal.

3. Quality Architectural Plans

High quality architectural plans which fully detail the architectural elements and project scope have a greater chance for successful Commission review. Project plans which provide a high level of detail are more likely to be successfully reviewed in a timely manner. Plans should include all of the

required details specified on the Planning Application checklist as well as specify a detailed project scope, materials, articulation, context, window details, etc. Plans which are lacking in detail and design that fail to meet the Residential Design Guidelines, and are poorly architecturally integrated into

the existing building form will take more time to process. Applicants are encouraged to work with licensed architects or experienced designers to plan their projects.

EXAMPLE SITE PLAN

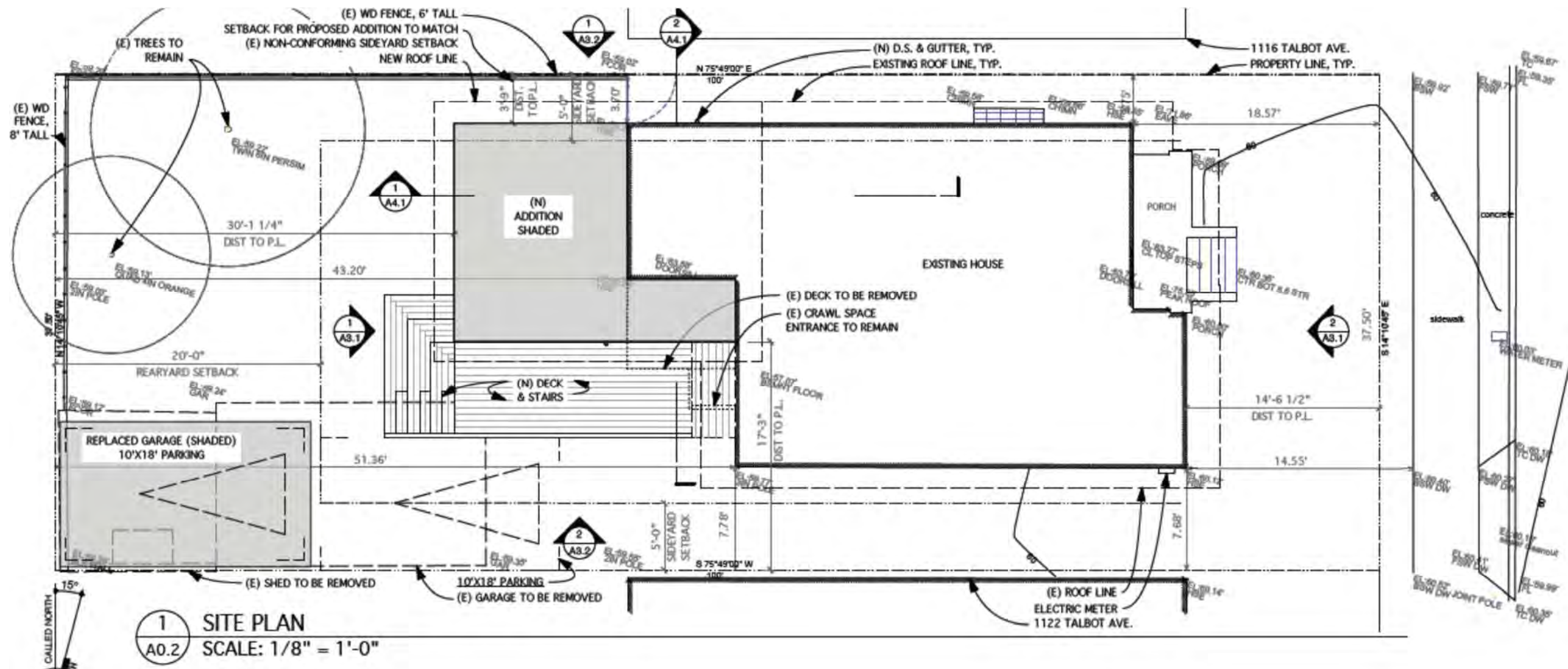

This site plan is dimensioned, scaled, has a North Arrow, differentiates between existing and new construction, show property setbacks, shows property lines, proposed parking as well as existing utilities and trees on site.

EXAMPLE ELEVATIONS

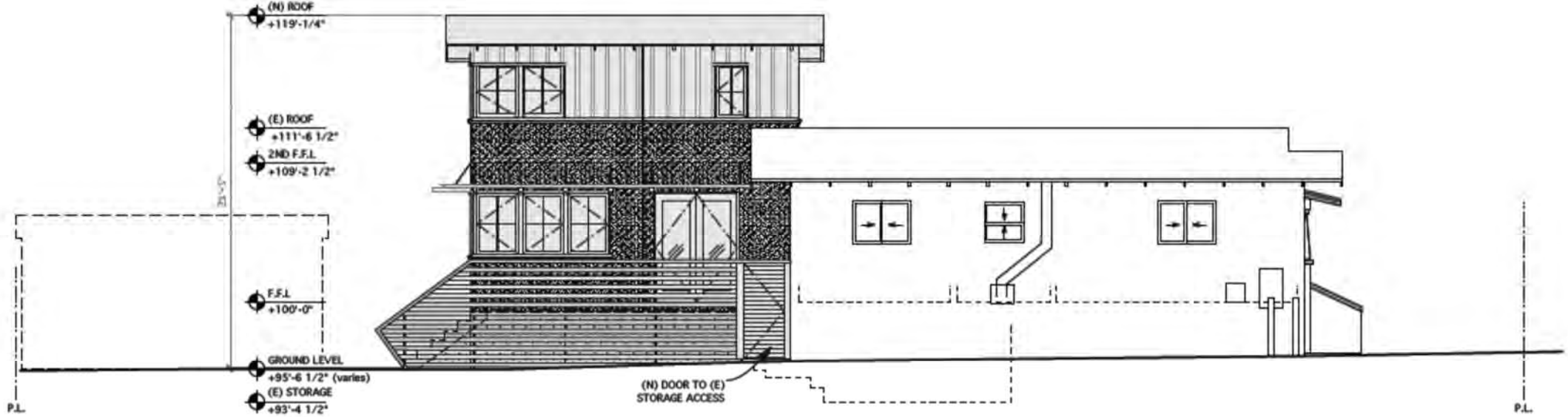

2 SOUTH ELEVATION
A3.2 SCALE: 1/8" = 1'-0"

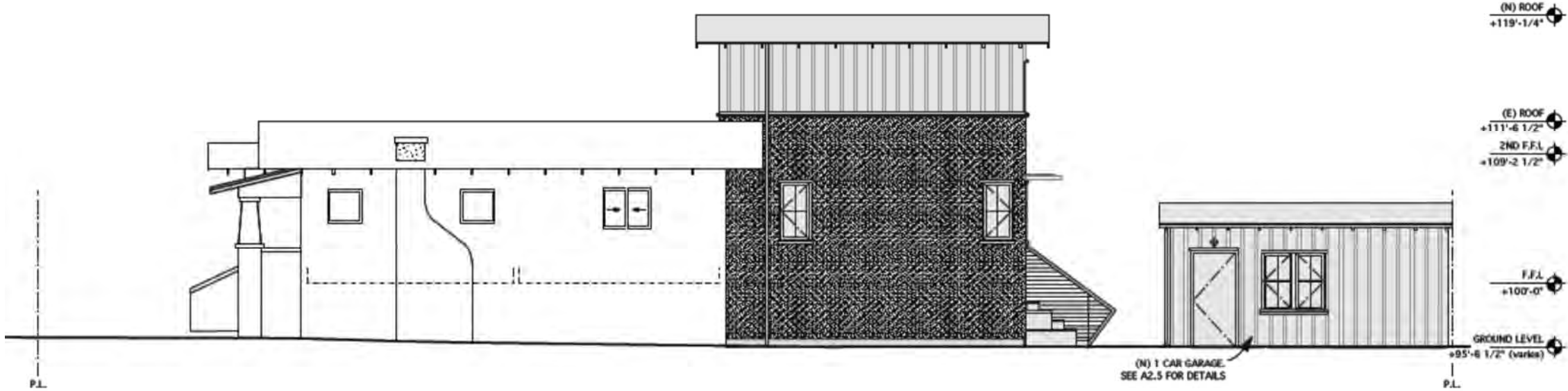

1 NORTH ELEVATION
A3.2 SCALE: 1/8" = 1'-0"

The proposed renderings are clearly labeled and show the existing and proposed building forms, site slope, finished floor, exterior materials, architectural details, and proposed garage.

THE 7 PRINCIPLES

The following Principles have been deemed important elements of residential design in the City of Albany. Within each principle are guiding criteria which identify design components for a successful project. Planning & Zoning Commissioners consider the prescribed criteria as they review proposed residential projects. This does not mean that every one of these is directly applicable to every project and site, but some attention paid to the spirit of each principle is strongly recommended. Flexibility may be granted for projects located in the Hillside Overlay District and Residential Hillside Development District.

1. Landscape Design
2. Outdoor Space
3. Architectural Design
4. Livability
5. Context
6. Accessory Dwelling Units
7. Parking

1 LANDSCAPE DESIGN

The front yard landscapes are the home's contribution to the community, playing an important aesthetic and functional role in home design.

The front yard provides a first impression of the property from the street. When designing a home addition, consideration should be given to landscape and hardscape improvements as well as street trees to enhance property appearance.

Good site design, efficient irrigation, careful plant selection and consistent maintenance can have a positive effect on your home's appearance as well as helping your community meet substantial goals.

- Projects which exceed a .45 Floor Area Ratio (FAR) are encouraged to prepare and submit a landscape plan showing proposed landscape

upgrades as part of the Planning application submittal.

- Landscape plans should include the plant species, respective location, and any proposed hardscape improvements.
- Conform to Bay Friendly landscaping practices
- The landscape design should demonstrate a relationship with the home.
- Landscaping is required to be installed prior to final Planning Inspection.
- Subject sites which do not have street trees are required to plant street trees as a Condition of Approval. (See Urban forester for permitted tree species.)

Landscaping Recommendations

- Shrubs and groundcovers should generally be spaced to create massing rather than

individual plants. (Canopies should touch each other at maturity.)

- While landscaping can be used to help provide a visual buffer or privacy screening to adjacent properties, it should not be relied on to mask, screen, or hide problematic architectural design.
- Landscape can reduce home energy costs and improve comfort by absorbing solar thermal load from the sun.
- Consider plants that are beneficial for insects and birds.
- Plants play a significant role in cleaning urban air by collecting dust and pollutants. Therefore, it is important for each home to contribute by adding living plants where feasible.
- Landscaping should follow Bay-Friendly landscape guidelines.
- Place trees, shrubs, and vines to reduce long term maintenance and property damage.

LANDSCAPE EXAMPLES



This yard has a low fence and retaining wall which helps to better define the front yard area as well as a trellis with climbing vines which alleviate and soften wall mass.



This yard has different textured plants with varying height and form. The flagstone entry defines the space to the front porch and the street tree provides shade.

PEDESTRIAN EMPHASIS

Defined paths for entry provide a pedestrian scale as well as a welcoming appearance.



This yard features a low fence and arbor entry with native plantings to define the front yard space and clear path of entry to the front porch/door.



This yard has repetition in the plantings as well as boulder wall and flagstone path. The planter strip features street trees and other plantings which make the street presence more attractive.

EXAMPLE LANDSCAPE PLAN

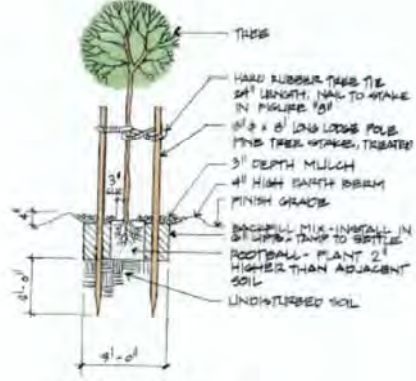
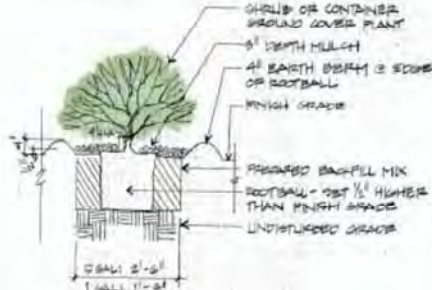
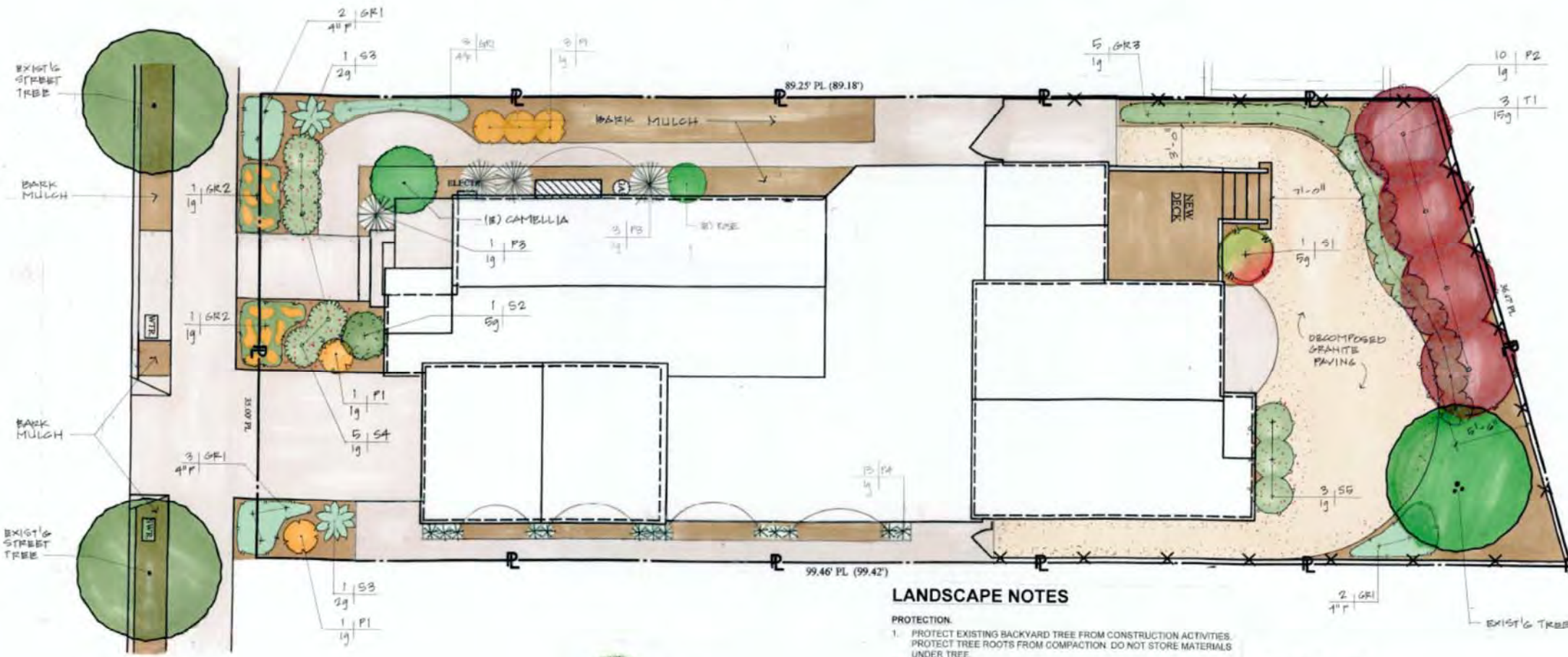

LANDSCAPE NOTES

- PROTECTION.**
1. PROTECT EXISTING BACKYARD TREE FROM CONSTRUCTION ACTIVITIES. PROTECT TREE ROOTS FROM COMPACTION. DO NOT STORE MATERIALS UNDER TREE.
- GENERAL.**
1. PLANTING SHALL BE PERFORMED BY PERSONS FAMILIAR WITH THIS TYPE OF WORK AND UNDER THE SUPERVISION OF A QUALIFIED FOREMAN.
 2. PLANTS STORED ON SITE SHALL BE WATERED DAILY.
 3. PLANT AND WATER WITHIN 30 MINUTES OF REMOVAL FROM FLATS OR CONTAINERS.
 4. PLANT TREES AND SHRUBS FIRST, THEN GROUND COVER PLANTS.
 5. HAND WATER INDIVIDUAL PLANTS DEEPLY AND THOROUGHLY IMMEDIATELY AFTER PLANTING.
- MULCH.**
1. AFTER PLANTING IS COMPLETE, MULCH ALL PLANTED AREAS IN A 3" LAYER OF BLACK ECO-MULCH.
- SITE CLEAN-UP.**
1. REMOVE ALL SURPLUS MATERIAL AND DEBRIS FROM THE SITE UPON COMPLETION OF THE WORK.

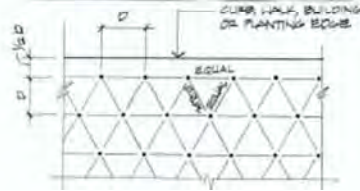

PLANT LIST

TREES	SHRUBS	PERENNIALS	GROUND COVER
T1 4-15 g	S1 1-5 g	P1 5-1 g	GR1 10-4' p
T2 1-5 g	S2 1-5 g	P2 10-1 g	GR2 2-1 g
S3 2-2 g	S3 2-2 g	P3 4-1 g	GR3 5-1 g
S4 5-1 g	S4 5-1 g	M4 13-1 g	
S5 3-1 g			

DODONAEA VISCOSA PURPUREA (STANDARD)	LEUCADENDRON RISING SUN	COREOPSIS GRANDIFLORA FLYING SAUCERS	SENECIO SERPENS	PURPLE HOPSEED BUSH	RIISING SUN CONEBUSH	TICKSEED	BLUE CHALKSTICKS
	CHOISYA TERNATA	SALVA CHAMAEDRIOIDES	LANTANA MONTEVIDENSIS GOLD RUSH	MOCK ORANGE	FOXTAIL AGAVE	GERMANDER SAGE	LANTANA
	AGAVE ATTENUATA	PENNISETUM ORIENTALE KARLEY ROSE	ANEMONE HYBRIDA	FOXTAIL AGAVE	KARLEY ROSE FOUNTAIN GRASS	KARLEY ROSE FOUNTAIN GRASS	JAPANESE ANEMONE
	SALVA MICROPHYLLA 'BERZERKLEY'	ALPAPANIHUS 'PETER PAN'		SAGE	DWARF LILY OF THE NILE	DWARF LILY OF THE NILE	
	SALVA MICROPHYLLA 'HOT LIPS'			SAGE			

2 OUTDOOR SPACE

Decks and balconies create usable outdoor space attached to the home and when properly architecturally integrated into the home, enhance the building appearance.

REAR YARD DECKS

Decks which are attached at the rear of the home and are more than 36 inches above grade are subject to administrative Design Review. When designing decks, consideration should be given to:

- Materials compliment home's architecture
- Guardrail/handrail design are consistent with overall home design
- Privacy considerations are taken into account
- Placement and massing of exterior stairs are aesthetically pleasing and functional
- Lighting fixtures are of high quality and compliment the home

ROOF DECKS

When proposed, roof decks are evaluated on a case by case basis by the Planning & Zoning Commission. Typically, the Commission evaluates the deck for privacy considerations, access and aesthetics. As part of the proposed roof deck design, the following considerations should be made:

- Integrated into of the architectural style of the home
- Stepped back from the building edge above the second floor
- Oriented away from neighbors' yards as much as possible
- Use appropriate screening measures to reduce privacy invasion (i.e. solid railing walls, latticework, and landscaping vegetation)

BALCONIES

When proposed, balconies should be architecturally integrated into the building form and have minimal impacts on neighboring properties. As part of the proposed balcony design, the following considerations should be made:

- Integrated into of the architectural style of the home
- Oriented away from neighbors' yards as much as possible;
- Decks and balconies should be no more than 6-8 feet in depth
- Consider the use of brackets for both aesthetic effect and structural support

3 ARCHITECTURAL DESIGN

Overall architectural design should aesthetically enhance existing structures and improve the building form and function. Qualities and features which are unique to the home serve to strengthen the overall visual appearance and character. When designing an addition, the following prescriptive criteria should be considered:

- Front Porches & Covered Entries
- Architectural Relief
- Trim & Details
- Paint Color
- Building Materials
- Window Details

FRONT PORCHES & COVERED ENTRIES

Porches create the transition between the public street and private home. Details such as the porch materials, railing, architectural style, etc., contribute to the aesthetics of the front façade and create an inviting appearance. A successful porch design has high quality materials and contributes aesthetically to the building façade.

Covered entries define the entrance to the home and define the relationship to the street. Entries may be located at the front or the side of the home, as is the case for many Macgregor homes. Porches may encroach up to 6 ft. in the front yard setback. It is important to note that when a porch has 3 sides (two walls and roof constitute an enclosure) it is included in the floor-area-ratio calculations.



Both of these homes feature a covered entry which is architecturally consistent with the main home. The roof lines and trim match the existing home. The design provides visual relief as it projects out from the main building. This style of porch/entry does not count towards Floor Area Ratio (FAR) as it is open on three sides.



PORCH ENTRY EXAMPLES



This porch is enclosed on more than two sides and counts towards the Floor Area Ratio.



This porch spans the width of the front façade and creates an inviting entry.

ARCHITECTURAL RELIEF

The mass of a building, its three-dimensional form, is evaluated for scale, bulkiness and relationship to exterior spaces. Architectural relief helps to reduce mass, creates variation in the building and wall plane form and adds varied visual interest to the home design. Relief can be created through different design details including off-set wall placement, different roof forms, canopy covers, different exterior finishing materials, trellis details, etc.



ORIGINAL DESIGN:

Continuous wall planes with blank features and minimal detailing are discouraged.

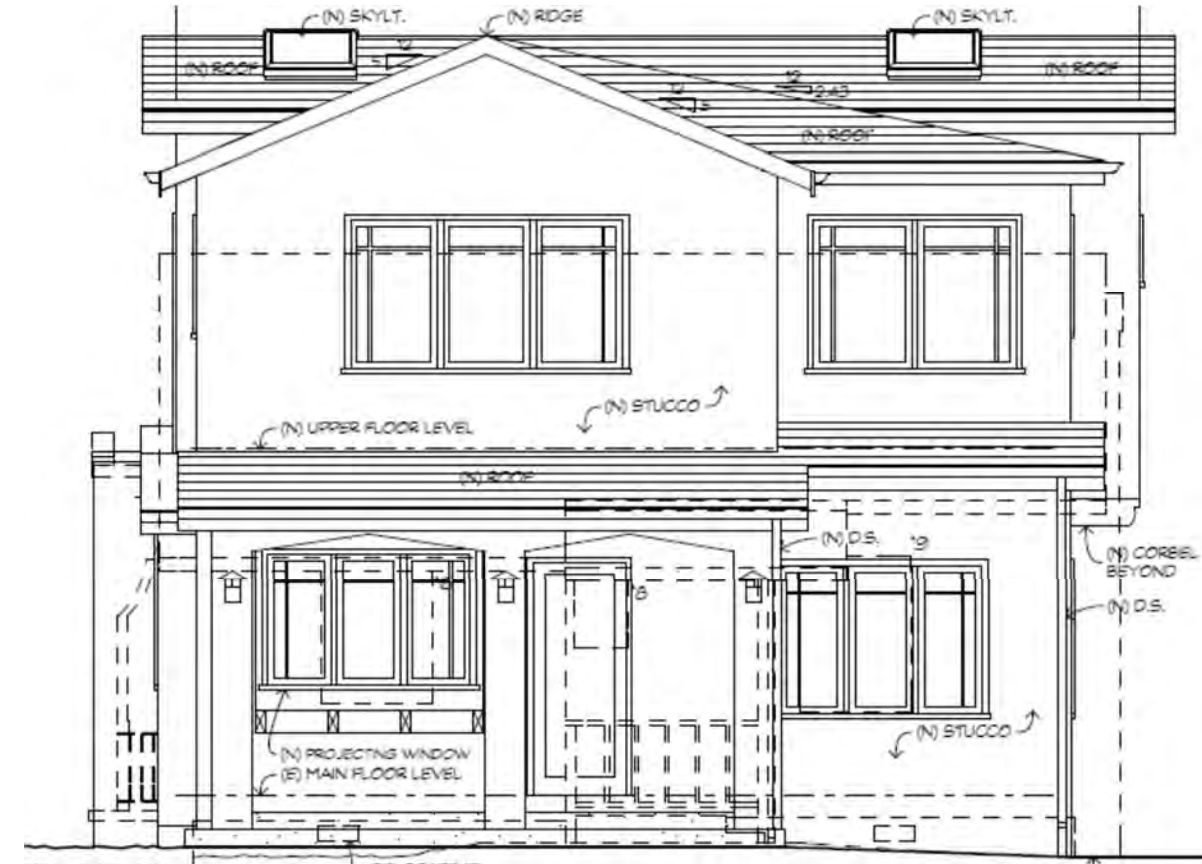

REVISED DESIGN:

Varied rooflines, consistent window details, and relief in the wall plane add visual interest and satisfy the Residential Design Guidelines.

ORIGINAL DESIGN

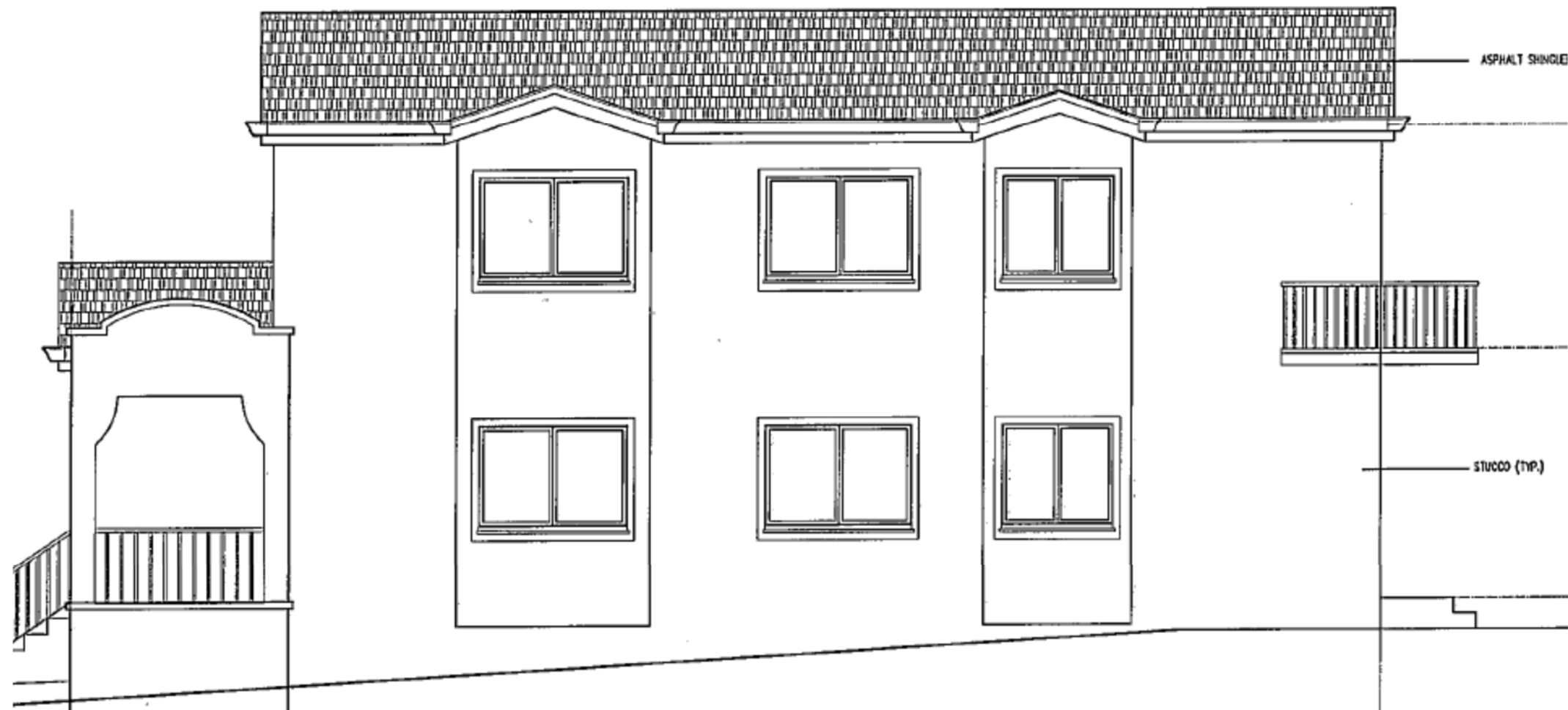

This rendering lacks details both visually and in plan notation. Minimal relief is provided with projecting bays.

REVISED DESIGN

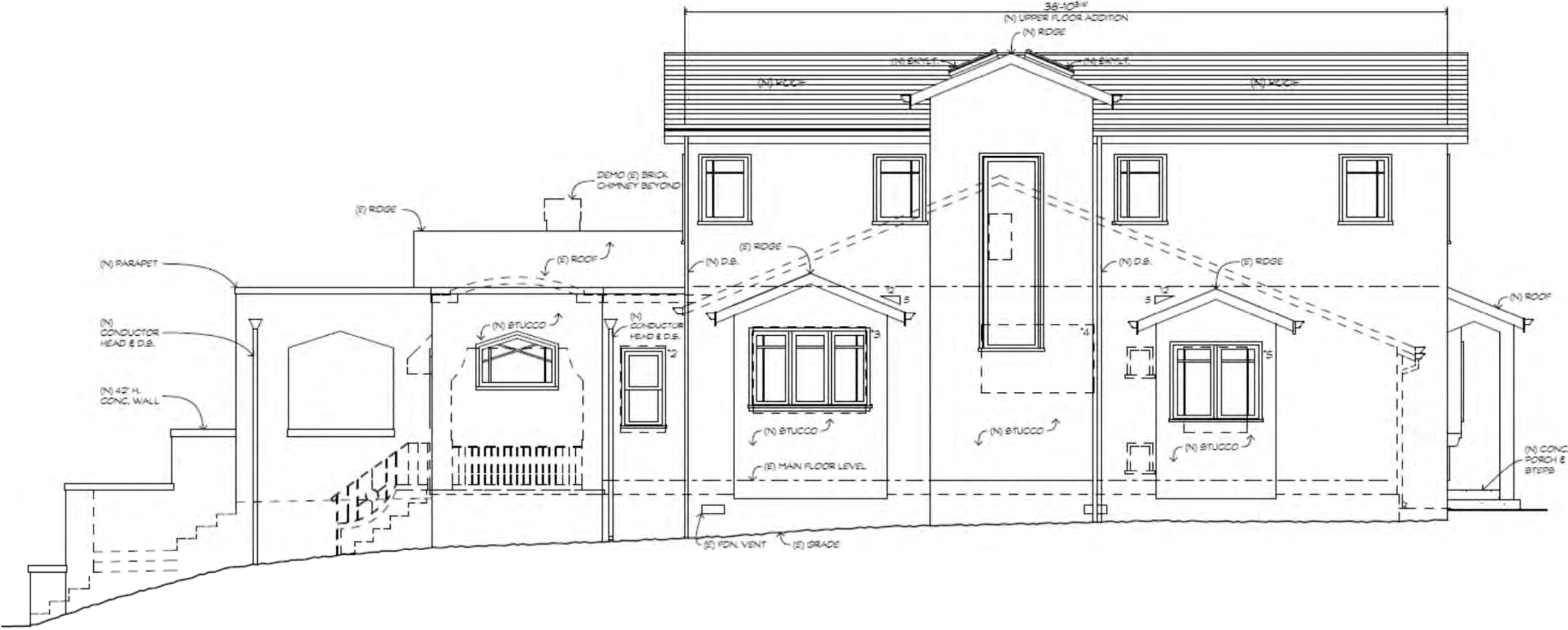

This rendering notes extensive details including building/roof materials, vents, roof pitch, new concrete, stucco, and windows proportional to the wall plane.

TRIM & DETAILS

Architectural details add visual appeal to a home and can help maintain architectural style and cohesiveness. Consistent use of small details is effective at adding visual interest and alleviating mass. The selected size should be proportional to the mass of the home. Details are encouraged to highlight the home entrance. Below are pictures of successful implementation of architectural details on homes in Albany. Architectural details include:



This home tapered columns, rafter tails, and true divided light windows. This design features brackets and a decorative vent under the gable. Corbel details & period specific light fixtures enhance the exterior.

OTHER CONSIDERATIONS

- **Utilities Placement.** To the extent possible, utilities including gas meters and electrical service drops should be located on the side of the home and not the front elevation.
- **Sprinkler Valves.** Landscape sprinkler valves should be concealed where feasible.
- **Trash Receptacle Storage.** Where feasible, trash receptacles should be stored away from street facing elevation.



A projecting bay with shed roof, decorative brackets, true divided lights, design appropriate light fixtures, and hardi-board siding on the bay, contribute to a successful design.



The consistent rafter tails, roof pitches, window trim, and exterior siding provides a great deal of visual interest in this home. Painting with regards to the various architectural details helps make this house.

PAINT COLOR

Paint color selection is not regulated by the City of Albany. However, applicants are encouraged to choose a color palette in collaboration with their architects, designers, as well as local paint stores that provide free paint color consultation. The pictures below illustrate exceptional usage of exterior paint color. It is important to note that trim colors are carried through on the window details and stucco relief treatments. Additionally, front doors which are painted a distinct color further define entry to the home.



PAINTED FRONT DOORS



Both of these homes have striking front doors and window trim colors to contrast with the paint of the main home. The home on the left has accentuated decorative tile and corbel details with paint.

BUILDING MATERIALS

Building materials and architectural finishes should possess physical properties and allow for appropriate maintenance procedures that ensure a long lifespan for the selected material. The specified building materials or architectural finishes should be appropriate to the architectural style of the residence and influence the overall aesthetic of the home. Homes built with high quality materials are more aesthetically pleasing and durable against the elements. Juxtaposing two or more different materials can be quite successful in producing strong aesthetic and can bring more visual diversity to the home/neighborhood.

When designing a home addition **consider** using:

- Wood
- Anodized aluminum
- Steel
- Brick
- Stucco
- Concrete bamboo
- Natural stone

When designing a home addition **avoid** using:

- Vinyl
- Plastic
- Foam trim



This rendering shows a contrast in exterior building materials including hardi-board and lap siding carried throughout the exterior of the home. Windows are symmetrical and proportional to the wall. The projecting bay adds visual interest while providing a natural light source to the stairwell.

WINDOWS

Window and door placement have a huge impact on the aesthetics of building facades. Window form adds interest to the building face and creates details that carried through the home cohesively. The surface of the glass should be recessed at least 2" from the wall plane to provide an adequate shade and shadow, unless approved otherwise by the Planning Commission in Design Review. Vinyl windows are strongly discouraged. If using divided lights, they must be "true divided" meaning the mullion details must be on the exterior of the glass. Attention should be paid to window color and trim color. A window schedule and plan detail is required for all Design Review applications.



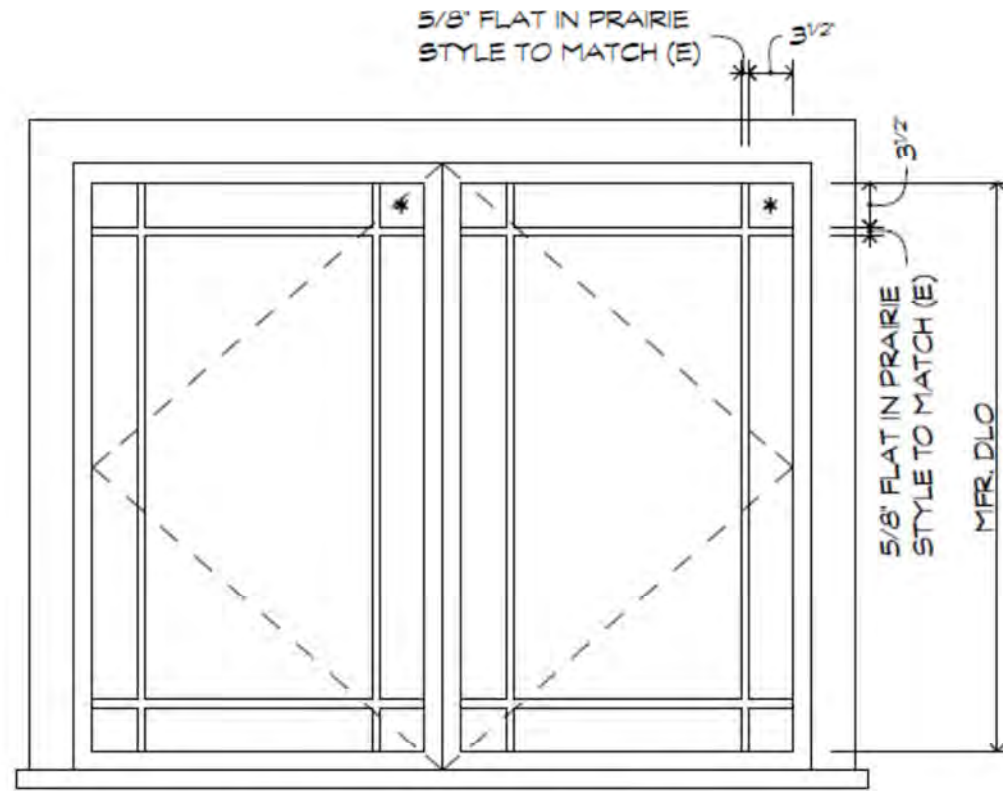
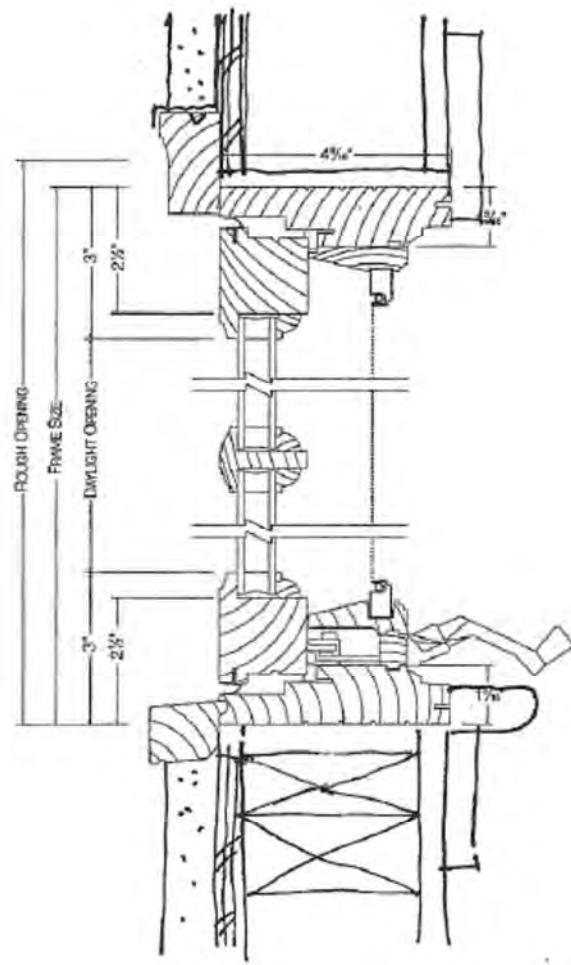

TYPICAL PAIR OF WINDOWS
VIEWED FROM EXTERIOR
* NEW DLO 3 1/2"W x 3 1/2"H

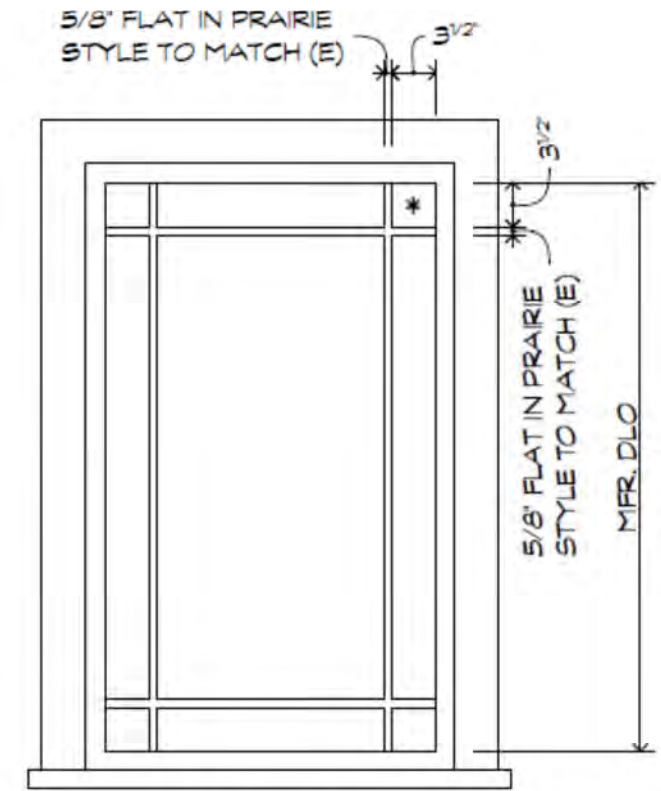

TYPICAL WINDOW
VIEWED FROM EXTERIOR
* NEW DLO 3 1/2"W x 3 1/2"H

A typical window submittal shall include a plan detail and rendering of the typical window with notation on the opening and manufacturer.

Other things to consider:

- Stucco foam border treatments are not acceptable.
- Faux divided light windows are not acceptable.
- Where proposed, shutters should be sized to match the size of the window.

4 LIVABILITY

Additions should be well integrated into the existing home, such that it looks like it was part of the original structure, or is a well-designed, well-proportioned and complementary addition. Extra care should be taken when approaching floor-area-ratio limits. Projects that exceed a 0.45 floor-area-ratio are subject to exceptional design as part of Design Review before the Planning & Zoning Commission. A home is built to last well into the future and house future occupants.

Interior Ceiling Heights

Interior plate heights drive building form as well as overall volume. When designing additions, consideration should be given to minimizing building volume which can be achieved through modest interior plate heights. In Albany's housing stock most plate heights range from 8 ft-9 ft. which helps to create nice interior space without increasing overall building mass.

Universal Design

Universal design in housing strives to make day-to-day living and home tasks possible and safer for everyone, allowing a person to remain independent for as long as possible. The design principles employ interior programming which accommodates occupants of all ages and abilities to live comfortably. The principles of universal design to all spaces, features, and aspects of houses and creates homes which are functional and allow occupants to age in place.

Expansion Types

- House Lift
- Attic Conversion
- Second Story Addition
- Lower Level Conversion

Sustainable Design

When proposing modification to a home, consider integrating solar panels or rain chains. Sustainability is important to think about with home improvements.



HOUSE LIFT



BEFORE



AFTER

This house was lifted and a new lower level space was created. By lifting and converting the lower level space, the total addition area was 213 sq. ft. The roof forms were also modified for greater consistency.

ATTIC CONVERSION



For attic spaces within sidewalls, low-plate heights and sloping ceilings can achieve interior volumes without adding excessive height and bulk to an addition. Additional habitable space was achieved in both homes with an attic conversion.

SECOND STORY ADDITION



BEFORE



AFTER

The architect preserved the existing building form, integrating the gable roof details in the second story addition. The rooflines have been setback from the building face to provide visual relief. The porch columns are preserved, new decorative brackets, thinner profile fascia trim, and consistent window details provide a detailed and cohesive appearance. New landscaping and a wider entry path create an inviting presence from the street.

LOWER LEVEL CONVERSION

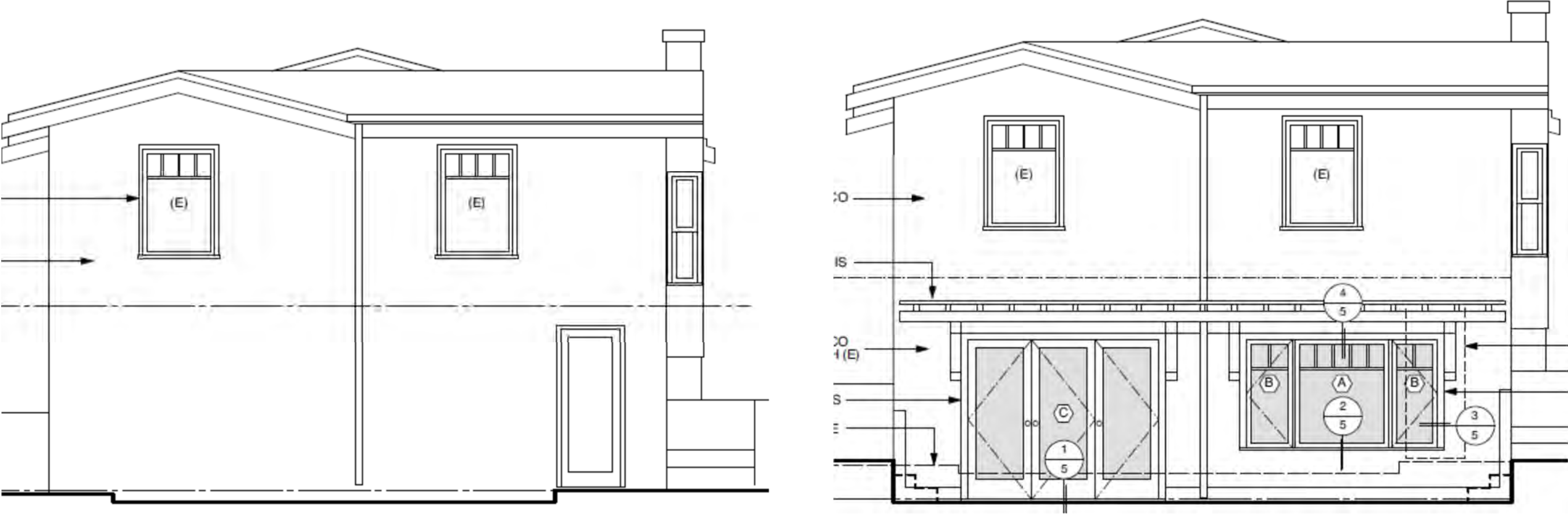

This home was expanded by approximately 540 sq. ft. on the lower level by excavating within the existing footprint of the home to create legal ceiling height on the lower level. The building footprint did not expand and the home height did not change.

5 CONTEXT

The façade of a building is the impression that a home offers to the outside world, demarcating the transition between the public and the private. Compatibility with adjacent homes creates a cohesiveness in the streetscape and a contextual relationship with adjacent properties and the surrounding urban fabric of the City.

There are a variety of existing site conditions to consider when designing a new house, addition, or proposing an aesthetic change to the façade of a home. Linking your proposal to the existing architecture, terrain/grading, adjacent properties, and even climate conditions can not only help justify a

design proposal before a Commission, but can also create a home that is context aware and suited for that specific lot. Even when desiring to change the existing architectural style of your home, consider the time context in which you are designing in. Utilizing current architectural and building trends/practices can help create a design that is contemporary, thus linking the home to the period in which it is being created and extending the life of the home for many years. Creating positive spaces that encourage engagement with the outdoors as well as the social interaction with the public, can help foster community through design. Design within a void is not design; good design is context aware as well as functional.





Privacy Considerations

When designing additions, consideration should be given to privacy impacts on adjacent properties. Wall placement, window placement and type, as well sight lines should be considered when designing an addition.

- Opaque glass may help to capture sunlight while preserving privacy
- When feasible, the south side of the home should be designed to capture sunlight
- Public rooms should be placed in front of the home facing the street

6 ACCESSORY DWELLING UNITS

An Accessory Dwelling Unit (ADU) is a separate dwelling unit that contains independent kitchen, sleeping and bathroom facilities and is located on a lot with a residential use and is subordinate to main dwelling. Many ADUs in Albany are utilized as rental units. It is important to provide a visual indicator at the street front so that postal carriers can ensure delivery. An Accessory Dwelling Unit permit is required through the Planning Department. This review is administrative and does not require a public hearing notice. Once the permit is approved, the applicant may apply for the Building Permit, which is a separate process. Residential lots zoned R-1, R-2, R-3, RHD in Albany may

have an Accessory Dwelling Unit (ADU). Accessory Dwelling Unit regulations were amended in 2014 to be consistent with State law and to facilitate the creation of new units. Accessory Dwelling Units are encouraged, and whether detached or attached, should complement the home and be integrated into the overall design.

*Please see Albany's Municipal Code sections 20.20.080 and 20.28.030 for more details regarding ADU regulations.



A recently completed architect designed Accessory Dwelling Unit, approximately 320 sq. ft. in area.



A pre-fabricated Accessory Dwelling Unit approximately 320 sq. ft. in area.

7 PARKING

Garages and Parking Are Important Considerations on Albany's Small Lots

Where front yard parking is permitted, it should make an aesthetic contribution to the street and mitigate visual impacts of a vehicle parked in the front yard. Attached garages should not exceed more than 40% of the building width. Single-car garages are preferred, but if a two-car garage is proposed, applicants are encouraged to include separate garage doors. The style of the garage door should be consistent with the home. Various types of materials such as steel, glass, sculpted wood, etc. are acceptable. Driveways and curb cuts should be minimal in width while still satisfying Code requirements for driveway width and off-street parking. This helps preserve on-street parking spaces as well as the overall property frontage aesthetics. Off-street vehicle parking should not project into the public right-of-way limiting pedestrian access.

Permitted Off-Street Parking Configurations Include:

- Uncovered Side-By-Side
- Uncovered Tandem
- Covered, two car garage
- Covered Tandem

Electric Vehicle Charging Stations

The popularity of electric vehicles has increased in recent years. With the popularity increase, more homeowners have applied to install electric vehicle (EV) chargers in the home. EV chargers may be installed by a licensed electrician with a City issued electrical permit. The property owner should verify that the car and all cords and equipment will be clear of sidewalks and not obstruct public right-of-way.

Garage Door Examples



Both these garage doors are a custom wood carriage style door.

Driveway Materials/Styles:



Flagstone



Concrete with decorative pavers



Hollywood strips with gravel

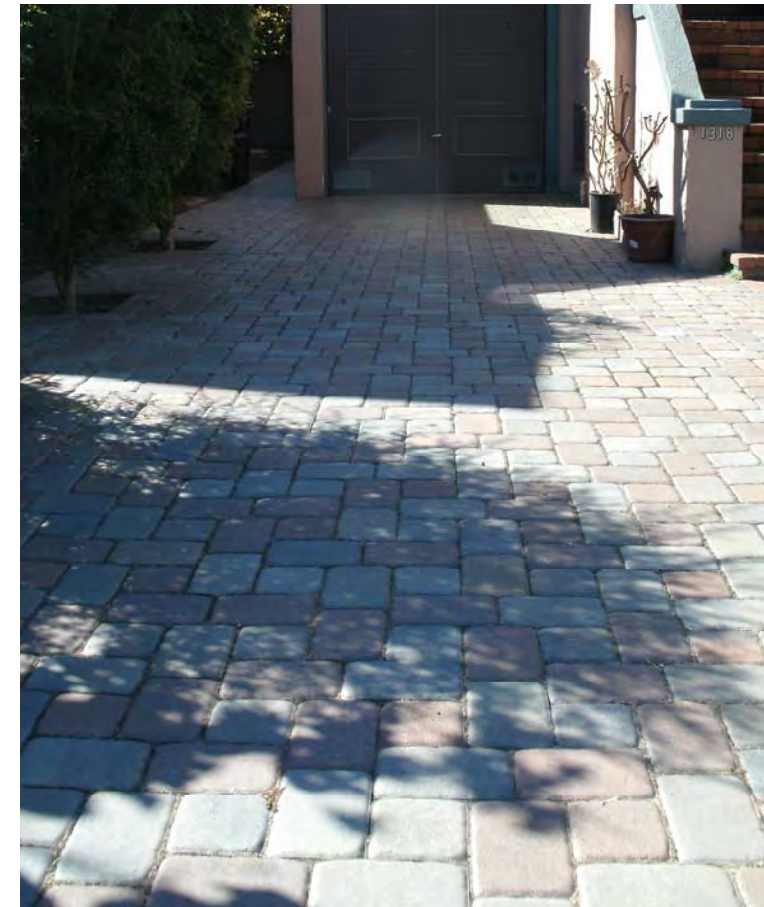

Pervious Pavers

ARCHITECTURAL CHARACTER 1910-1950



Both of these large and expanded homes represent Spanish Revival architecture.

The City of Albany was incorporated in 1908 and the majority of the housing stock encompasses architectural styles from 1910-1950. Architectural styles represented in Albany include but are not limited to:

- Spanish Revival
- Tudor
- Craftsman
- Minimal Traditional

The original design elements and form which reflect architectural styles of the past are considered an asset to the community and adds character to the City of Albany. Recognizing and carrying over existing architectural elements/details is important when proposing an addition or remodel to an older home. Maintaining and integrating original design elements can make for a remodeled home that is true to its original architecture style.



This home represents the Tudor architectural style with steeply sloped rooflines and cross gable details.



This home represents the Craftsman architectural style with decorative brackets, rafter tails, gable covered entry and cross gable roofline.



Both of these homes represent the Minimal Traditional architectural style.



BEFORE

This traditional MacGregor home's visibility was compromised, and the home was in poor condition.



AFTER

This project is a successful execution of a 2nd story addition that carries over the existing architectural design of a traditional MacGregor home.



BEFORE



AFTER

This Macgregor home was remodeled and included a modest second story addition integrated into the existing building form. Original details including the clay tile roof, decorative vent pipes, eyebrow roof, and picture window were preserved. The applicant carried mullion details from the picture window into the new window schedule and replaced the garage door with a custom wood door.



BEFORE



AFTER

The second story addition was designed to match the existing Tudor architecture and nicely integrated into the existing home. Steep pitched roof details as well as trim and gutters are incorporated into the new design. Vinyl window inserts were replaced with true divided light windows with wood frames. The bay is accentuated with paint to match the roof and gutter trim.

CONTEMPORARY ARCHITECTURE



Contemporary architecture can create a streetscape that is just as dynamic as traditional homes. Contemporary homes in Albany add to the city's visual interest as well as provide another architectural type that can be reflective of the residents who live here. These examples of modern homes in Albany illustrate successful execution of contemporary architectural design. New construction projects may consider this architectural style when submitting for design review. In conjunction with general applicable design principles, features of contemporary homes include but are not limited to:

- High placed and larger window openings
- Building materials including aluminum, corrugated metal siding and horizontal wood siding
- Butterfly, shed or flat roof forms
- Aluminum and glass garage doors
- Cable suspended overhangs, awnings, and/or three-dimensional element to break up a flat wall plane.



This house incorporates a blend of traditional architecture with the roof forms and contemporary details such as the horizontal wood paneling and metal garage door with frosted glass.



This contemporary home embraces both flat and sloped roof forms along with a mostly monochrome color palette in addition to different materials for siding.



This contemporary home, though not yet constructed, has been approved by the Planning and Zoning Commission. The home has vertical redwood slats on the exterior, ceiling-floor windows, and a vibrant front entry door.



This home has a contemporary building form, modern garage door with an aluminum frame and frosted glazing, and a roof deck.



The use of shed roof, board and batten siding, and a striking color palette contribute to the modern aesthetic.



A flat roof, large window openings, horizontal slat cedar siding to accentuate projecting bays, and a modern color palette highlight the modern design.

BEFORE & AFTER



BEFORE



AFTER

An expanded, architecturally appropriate front porch, removal of vinyl siding, new cedar siding, new landscaping and street trees, and appropriate trim and details enhance the curb appeal of this home.



BEFORE



AFTER

Fresh paint, new landscaping, new windows, exterior light fixtures and second story addition integrated into the existing building form remarkably improve the appearance of the home. The natural wood finish on the front door and side gate match, improving the contrast to the front elevation. The painted garage door also adds visual interest.



BEFORE



AFTER

A new roof with period appropriate design, new paint, windows, landscaping, and defined entrance path make the home inviting to passersby. Window trim has been painted to contrast with the color of the home and better define the window opening.



BEFORE



AFTER

Before the renovation, the only visible portion of the home facing the street was the garage. A Hollywood Juniper tree was removed and the addition was located above the existing single-car garage, creating a new architectural form and establishing a relationship with the street. Trim under the new gable roof with decorative vents adds nice architectural treatment. A new pervious paver driveway was also added, defining the uncovered parking and creating a new garden area and path to the front door.



BEFORE



AFTER

The architect preserved the existing Craftsman form and enhanced the building with larger window openings, contrasting materials (hardi-board), decorative brackets and a complimentary paint scheme.



BEFORE



AFTER

Before the addition, the home possessed a Craftsman appearance with modest detailing and minimal landscaping. The second story addition maintains the same gable and rafter tails with modern details including wood windows, a cable guardrail, hardi-board siding on the second story, new street trees and new landscaping.

EXCEPTIONAL DESIGN

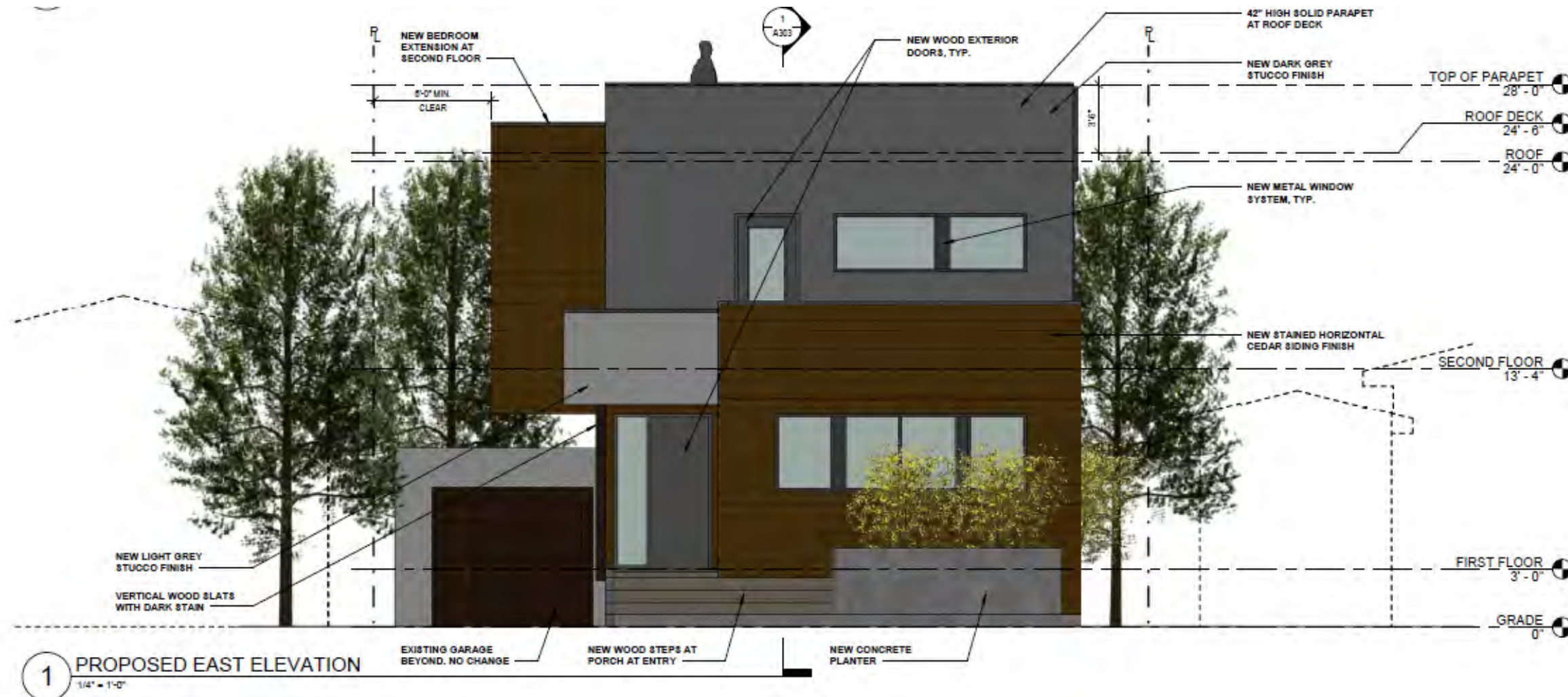

Projects which exceed a **.45 floor-area-ratio** are subject to exceptional design as reviewed by the Planning & Zoning Commission. Exceptional design includes, but is not limited to high quality exterior finishes, variation in exterior materials, variation in wall plane depths and projections, consistent window language, complimentary landscaping, and consideration to off-street parking.