

GENERAL NOTES:

- ALL WORK SHALL CONFORM TO THE 2010 EDITION OF THE STATE OF CALIFORNIA DEPARTMENT OF TRANSPORTATION (CALTRANS) STANDARD PLANS AND SPECIFICATIONS AND SPECIAL PROVISIONS, AND THE 2012 CALIFORNIA MANUAL ON UNIFORM TRAFFIC CONTROL DEVICES (CA MUTCD).
- ALL PAVEMENT STRIPING AND MARKINGS SHALL BE THERMOPLASTIC, MINIMUM 0.15" THICK.
- EXISTING STRIPING AND PAVEMENT MARKINGS THAT ARE IN CONFLICT WITH PROPOSED STRIPING AND PAVEMENT MARKINGS SHALL BE REMOVED AND DISPOSED OF PER SECTIONS 15-2.02 (B&C) AND 15-2.03 OF THE STATE STANDARD SPECIFICATIONS.
- ALL SIGNING, STRIPING, AND PAVEMENT MARKINGS SHALL BE CAT-TRACKED AND APPROVED BY THE CITY ENGINEER OR AUTHORIZED REPRESENTATIVE PRIOR TO FINAL INSTALLATION.
- ALL EXISTING SIGNS TO REMAIN UNLESS NOTED OTHERWISE.
- CLEARANCE FROM THE GROUND TO THE BASE OF ALL SIGNS SHALL BE 7' MINIMUM.

LEGEND:

- + INSTALL NEW ON STREET PARKING STALL MARKING.
- ▲ BEGIN STRIPING TRANSITION
- ✚ CHANGE IN STRIPING DETAIL
- REMOVE ROADSIDE SIGN
- ▲ RELOCATE EXISTING ROADSIDE SIGN ON NEW POST
- ROADSIDE SIGN TO REMAIN
- ➔ EXISTING TYPE II (L)/(R) PAVEMENT ARROW
- ➔ EXISTING TYPE III (L)/(R) PAVEMENT ARROW
- ➔ EXISTING TYPE IV (L)/(R) PAVEMENT ARROW
- ➔ REMOVE EXISTING PAVEMENT STRIPE, ARROW OR LEGEND (BY GRINDING)
- ➔ EXISTING TYPE VI PAVEMENT ARROW
- XXX EXISTING PAVEMENT DELINEATION DETAIL NUMBER
- XW REMOVE CROSSWALK
- LL REMOVE LIMIT LINE
- ◻ EXISTING ROADSIDE SIGN
- ◻ EXISTING ROADSIDE SIGN
- LL INSTALL NEW LIMIT LINE
- XW INSTALL NEW CROSSWALK
- XXX INSTALL NEW PAVEMENT DELINEATION DETAIL NUMBER
- ◻ INSTALL NEW ROADSIDE SIGN
- ➔ INSTALL NEW TYPE I ARROW
- ➔ INSTALL NEW TYPE II (L)/(R) ARROW
- ➔ INSTALL NEW TYPE III (L)/(R) ARROW

LEGEND (CONTINUED):

- ➔ INSTALL NEW TYPE IV (L)/(R) ARROW
- ➔ INSTALL NEW TYPE VI PAVEMENT ARROW
- ➔ INSTALL NEW TYPE VII (L)/(R) ARROW
- ➔ INSTALL NEW TYPE VIII (L)/(R) ARROW
- ➔ BIKE LANE ARROW AND BIKE LANE SYMBOL PER CALTRANS STD PLANS A24A AND A24C
- ➔ INSTALL NEW SHARED ROADWAY BICYCLE MARKING (SHARROW) PER DETAIL ON THIS SHEET.
- INSTALL NEW STOP LEGEND.

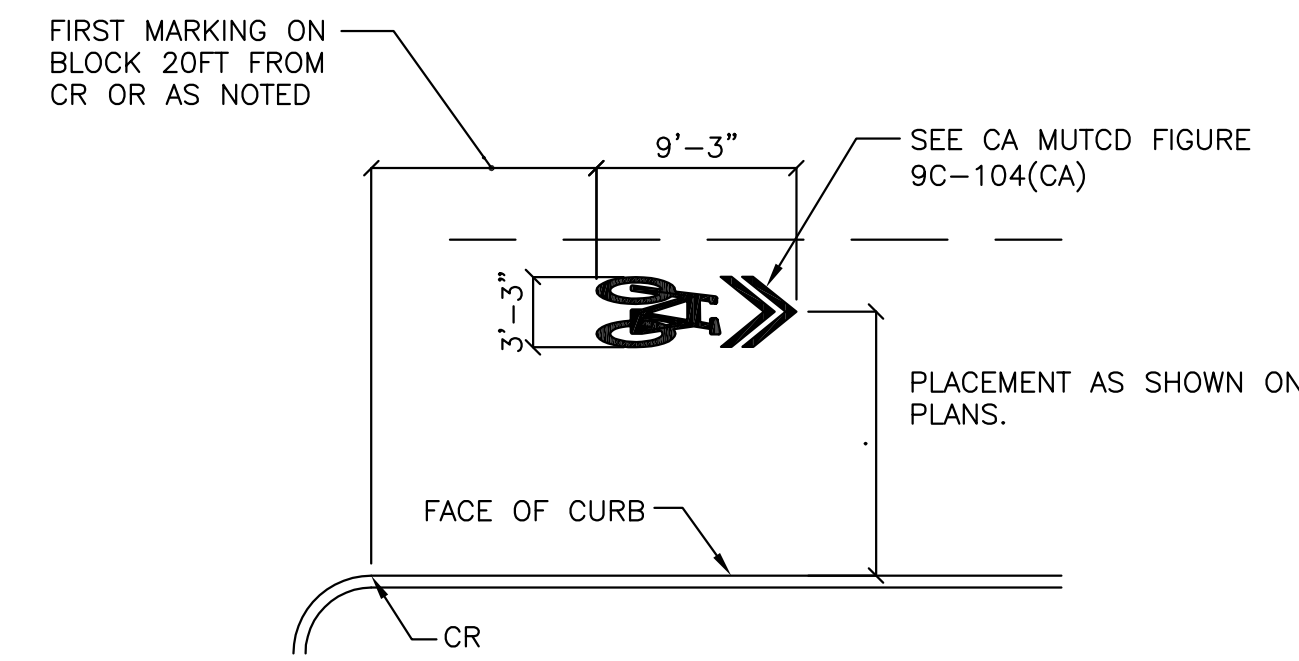

DETAIL 'A'
SHARED ROADWAY BICYCLE MARKING
N.T.S.

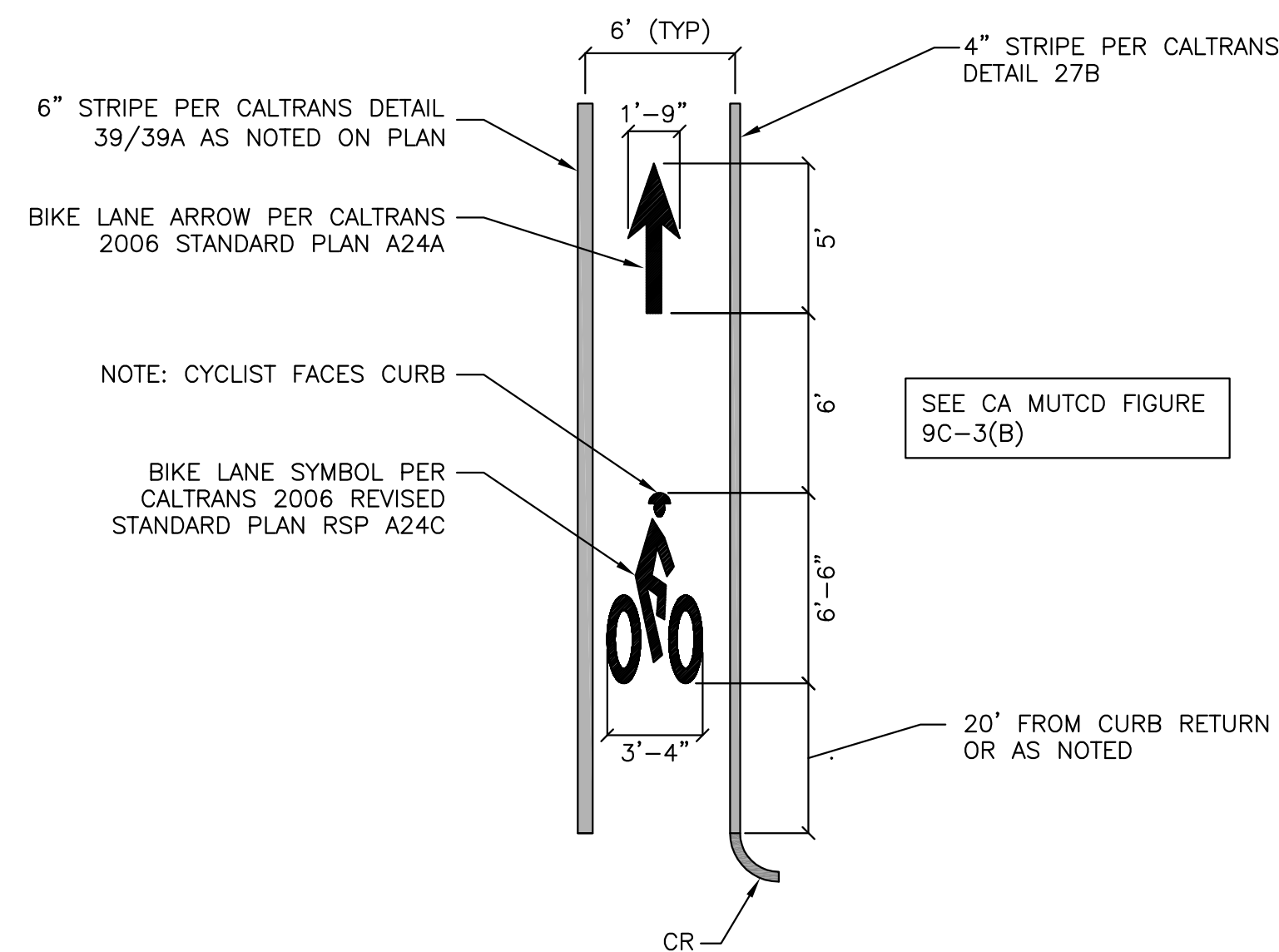

DETAIL 'B'
BIKE LANE DETAIL
N.T.S.

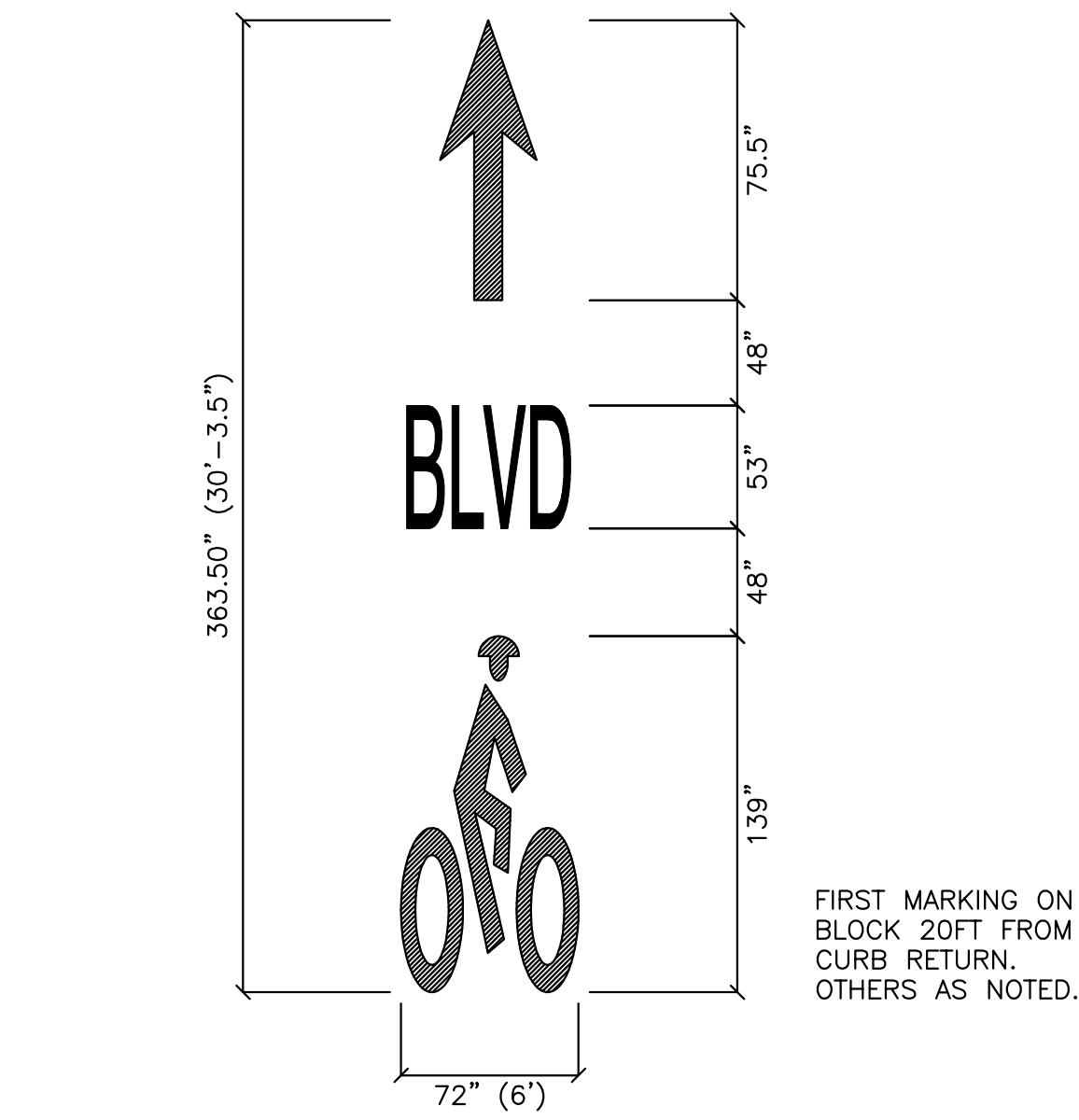

DETAIL 'C'
BIKE BOULEVARD MARKING DETAIL
N.T.S.

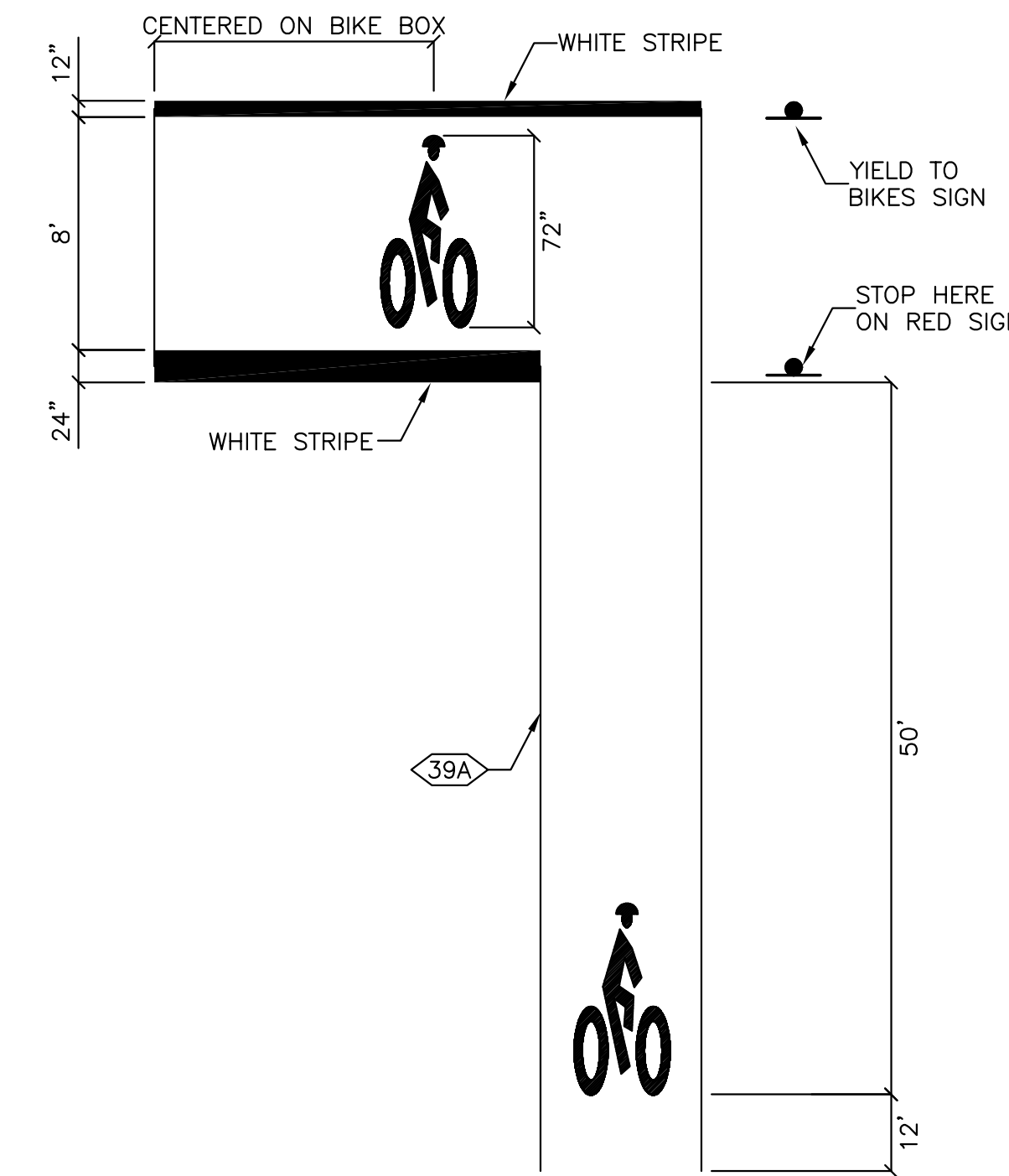

DETAIL 'D'
BICYCLE BOX
N.T.S.

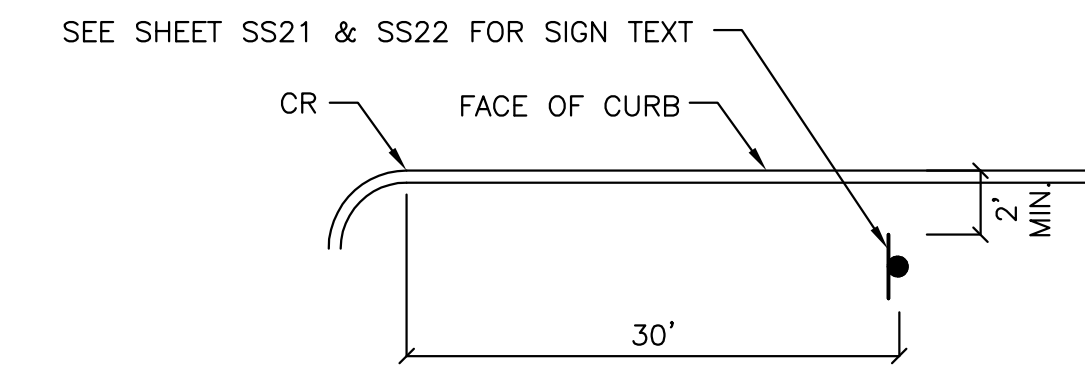

DETAIL 'E'
TYPICAL GUIDE SIGN
INSTALLATION LAYOUT
N.T.S.

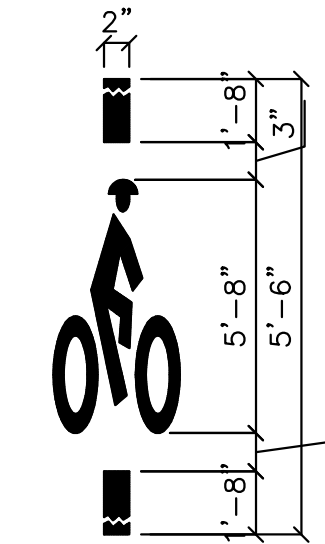

DETAIL 'F'
BICYCLE LOOP
DETECTOR SYMBOL
N.T.S.

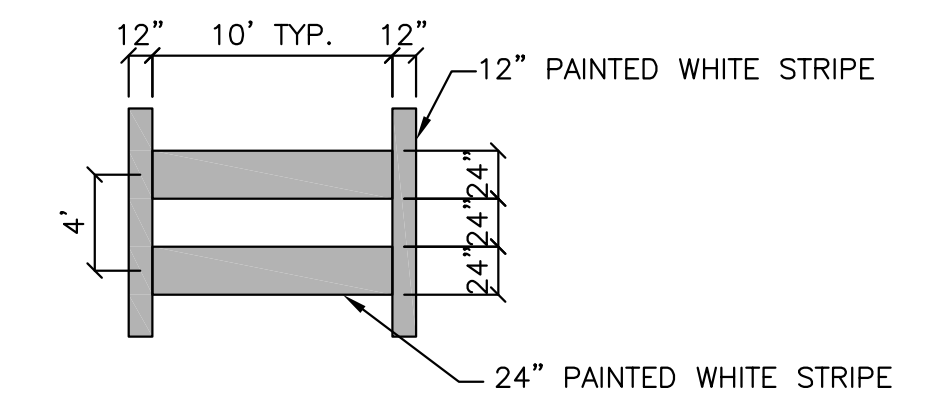

DETAIL 'G'
CROSSWALK DETAIL
N.T.S.

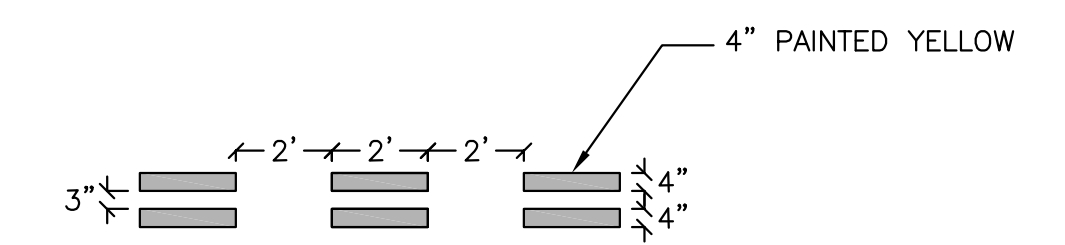

DETAIL 'H'
MODIFIED DETAIL 21
N.T.S.

BEFORE EXCAVATING
CALL U.S.A.
UNDERGROUND SERVICE ALERT
811/800-227-2600
48 HOURS BEFORE ALL
PLANNED WORK OPERATIONS

NO.	DESCRIPTION	DATE	BY

FEHR & PEERS

100 Pringle Avenue Walnut Creek, CA 94596
Suite 600 (925) 930-7100

Walnut Creek, CA San Diego, CA
 Roseville, CA Oakland, CA
 San Jose, CA Salt Lake City, UT
 San Francisco, CA Reno, NV
 Orange County, CA Denver, CO
 Los Angeles County, CA Seattle, WA



Designed By: PS/RM
 Drawn By: PS/DD
 Checked By: RM
 Drawing No.: WC13-3073
 Date: 11/07/2014

ALBANY ACTIVE TRANSPORTATION PLAN
 SIGNING & STRIPING
 GENERAL NOTES & DETAILS

SHEET
 SS1
 OF
 23

Nov 07, 2014 CADD FILE: \\F:\p\03\w-c-deta\PROJECTS\WC13\WC13-3073-Albany_ATP_Signing-Striping\Signage\CAD\65_Submittal\3073-SS1_L588-ATP_3-15.dwg

Fehr & Peers Associates, its employees, its officers or agents shall not be responsible for the accuracy or completeness of electronic copies of this plan sheet.

PROJECT NOTES (THIS SHEET ONLY):

- 1 INSTALL SHARROW PER DETAIL 'A' ON SHEET SS1.
- 2 INSTALL BIKE LANE STENCIL PER DETAIL 'B' ON SHEET SS1
- 3 INSTALL BICYCLE BOX PER DETAIL 'D' ON SHEET SS1
- 4 INSTALL GUIDE SIGN PER DETAIL 'E' ON SHEET SS1. SEE SHEET SS21 FOR SIGN TEXT.
- 5 INSTALL BIKE BOULEVARD STENCIL PER DETAIL 'C' ON SHEET SS1
- 6 INSTALL MODIFIED DETAIL 21 PER DETAIL 'H' ON SHEET SS1
- 7 INSTALL BIKE LEGEND WITH LEFT TURN ARROW
- 8 INSTALL STOP LEGEND

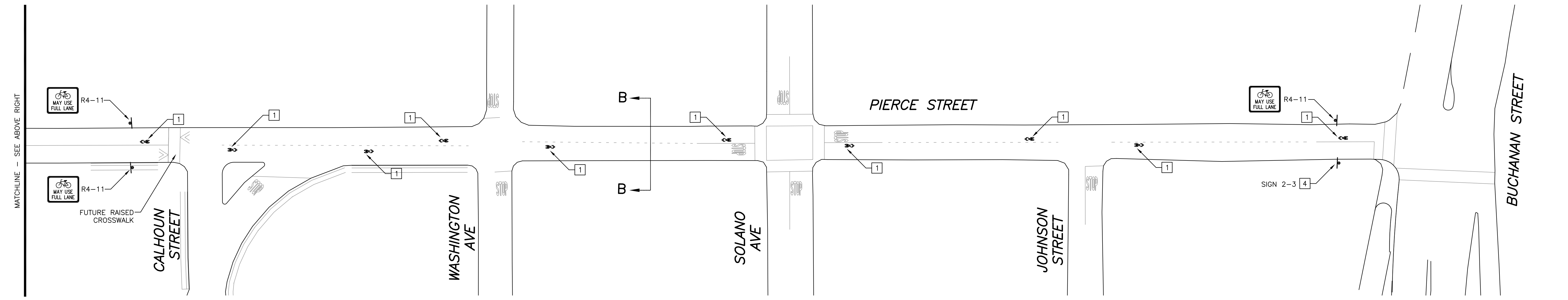
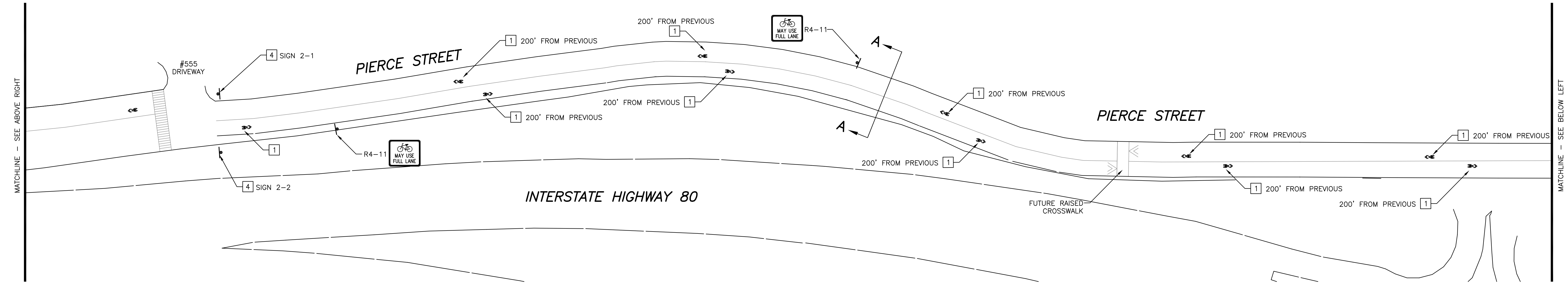
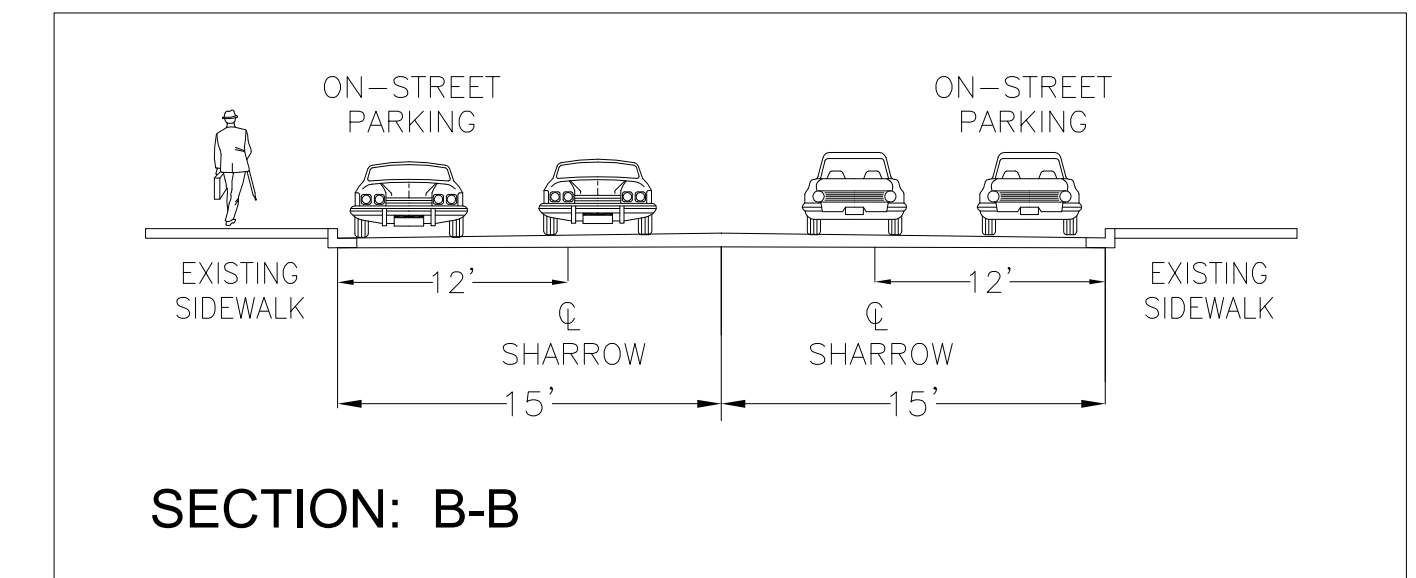
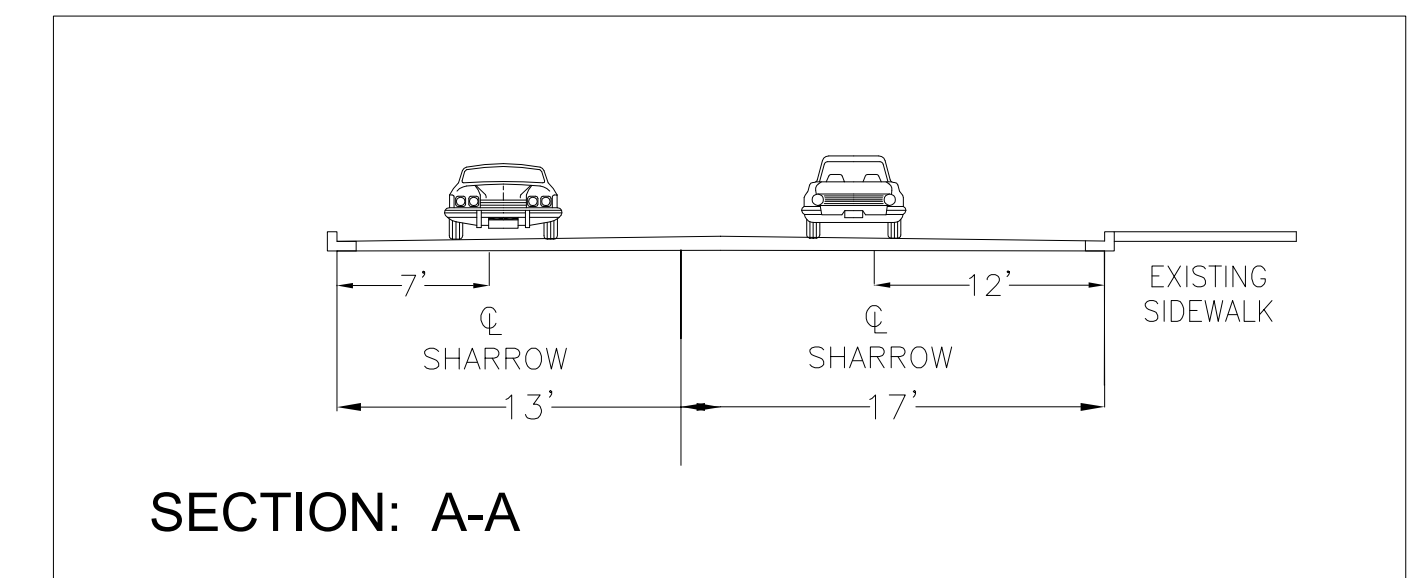
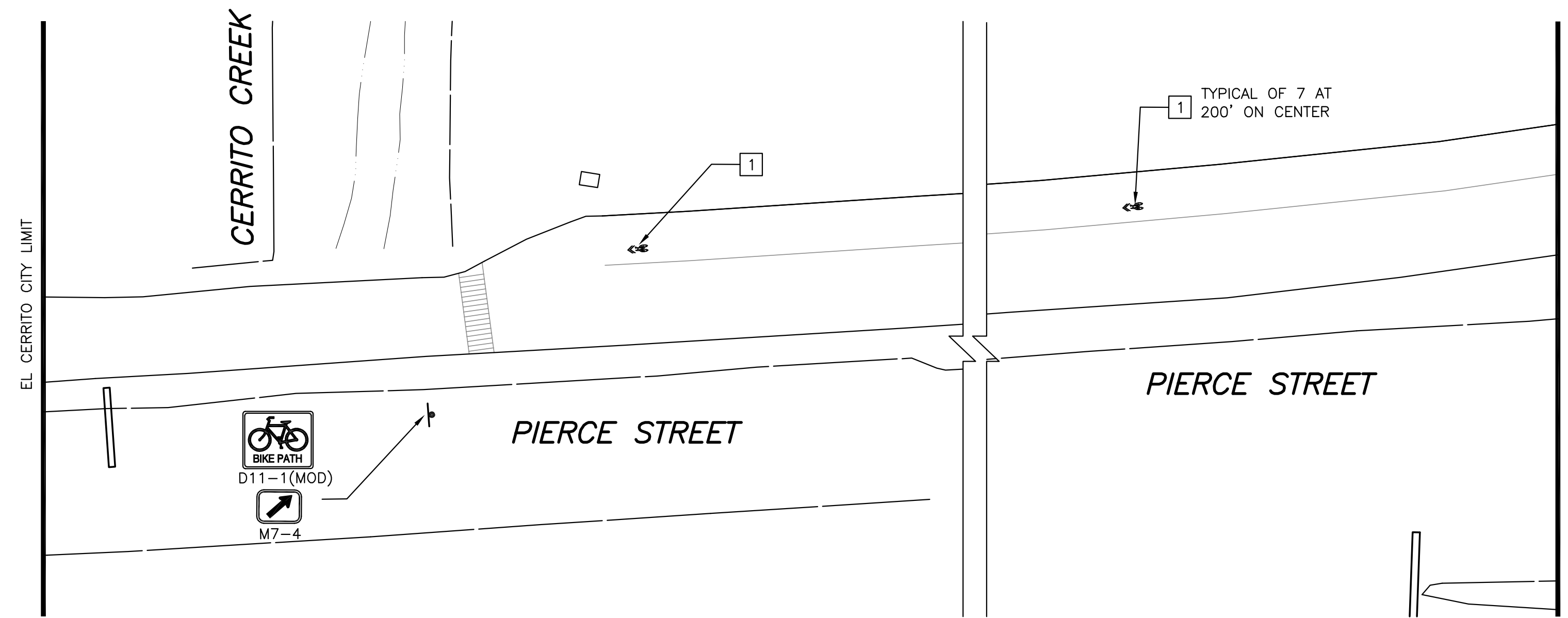
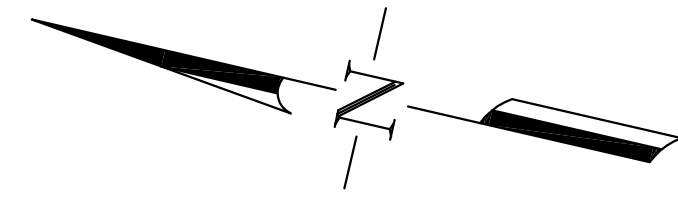

Nov 07, 2014 CADD FILE: N:\PROJECTS\WC13\WC13-3073-Albany_ATP_Signing-Scoping\CAD\65_Submittal\3073-SS1_SS8-ATP_3-15.dwg

NO.	DESCRIPTION	DATE	BY

FEHR & PEERS

100 Pringle Avenue Walnut Creek, CA 94596
(925) 930-7100

Walnut Creek, CA San Diego, CA
 Roseville, CA Oakland, CA
 San Jose, CA Salt Lake City, UT
 San Francisco, CA Reno, NV
 Orange County, CA Denver, CO
 Los Angeles County, CA Seattle, WA



Designed By: PS/RM
 Drawn By: PS/DD
 Checked By: RM
 Drawing No.: WC13-3073
 Date: 11/07/2014

ALBANY ACTIVE TRANSPORTATION PLAN
ATP PROJECT #3 - PIERCE STREET
SIGNING & STRIPING PLAN

SHEET
 SS2
 OF
 23

Fehr & Peers Associates, its employees, its officers or agents shall not be responsible for the accuracy or completeness of electronic copies of this plan sheet.

PROJECT NOTES (THIS SHEET ONLY):

- 1 INSTALL SHARROW PER DETAIL 'A' ON SHEET SS1.
- 2 INSTALL BIKE LANE STENCIL PER DETAIL 'B' ON SHEET SS1
- 3 INSTALL BICYCLE BOX PER DETAIL 'D' ON SHEET SS1
- 4 INSTALL GUIDE SIGN PER DETAIL 'E' ON SHEET SS1. SEE SHEET SS21 FOR SIGN TEXT.
- 5 INSTALL BIKE BOULEVARD STENCIL PER DETAIL 'C' ON SHEET SS1
- 6 INSTALL MODIFIED DETAIL 21 PER DETAIL 'H' ON SHEET SS1
- 7 INSTALL BIKE LEGEND WITH LEFT TURN ARROW
- 8 INSTALL STOP LEGEND

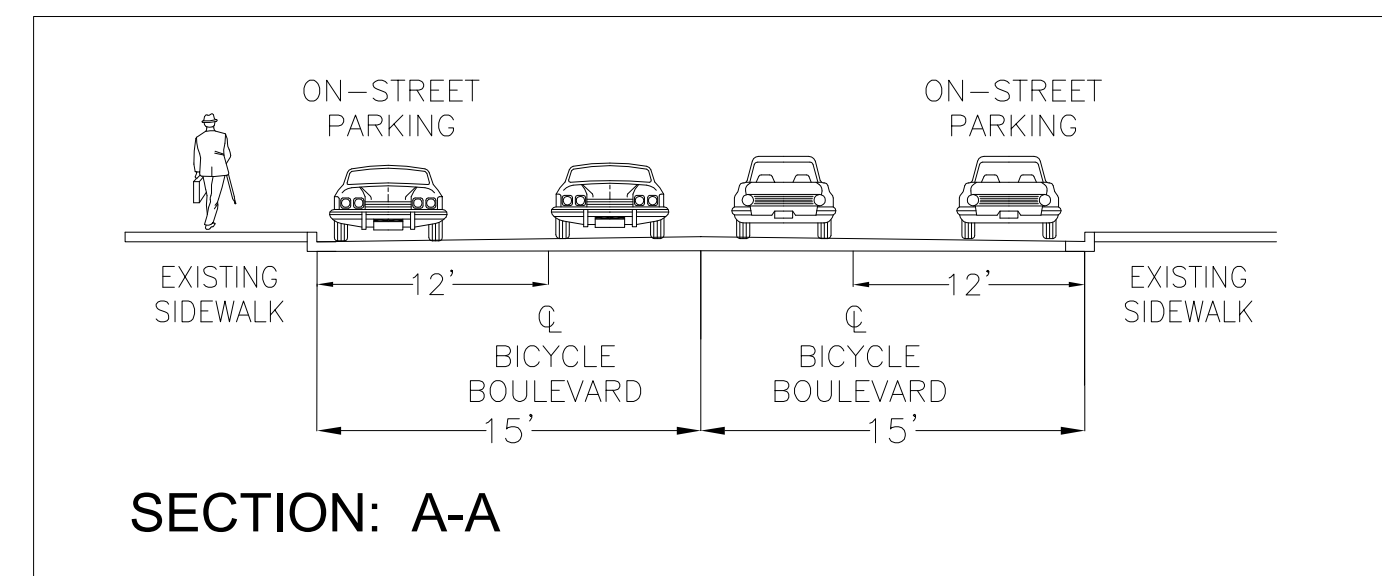
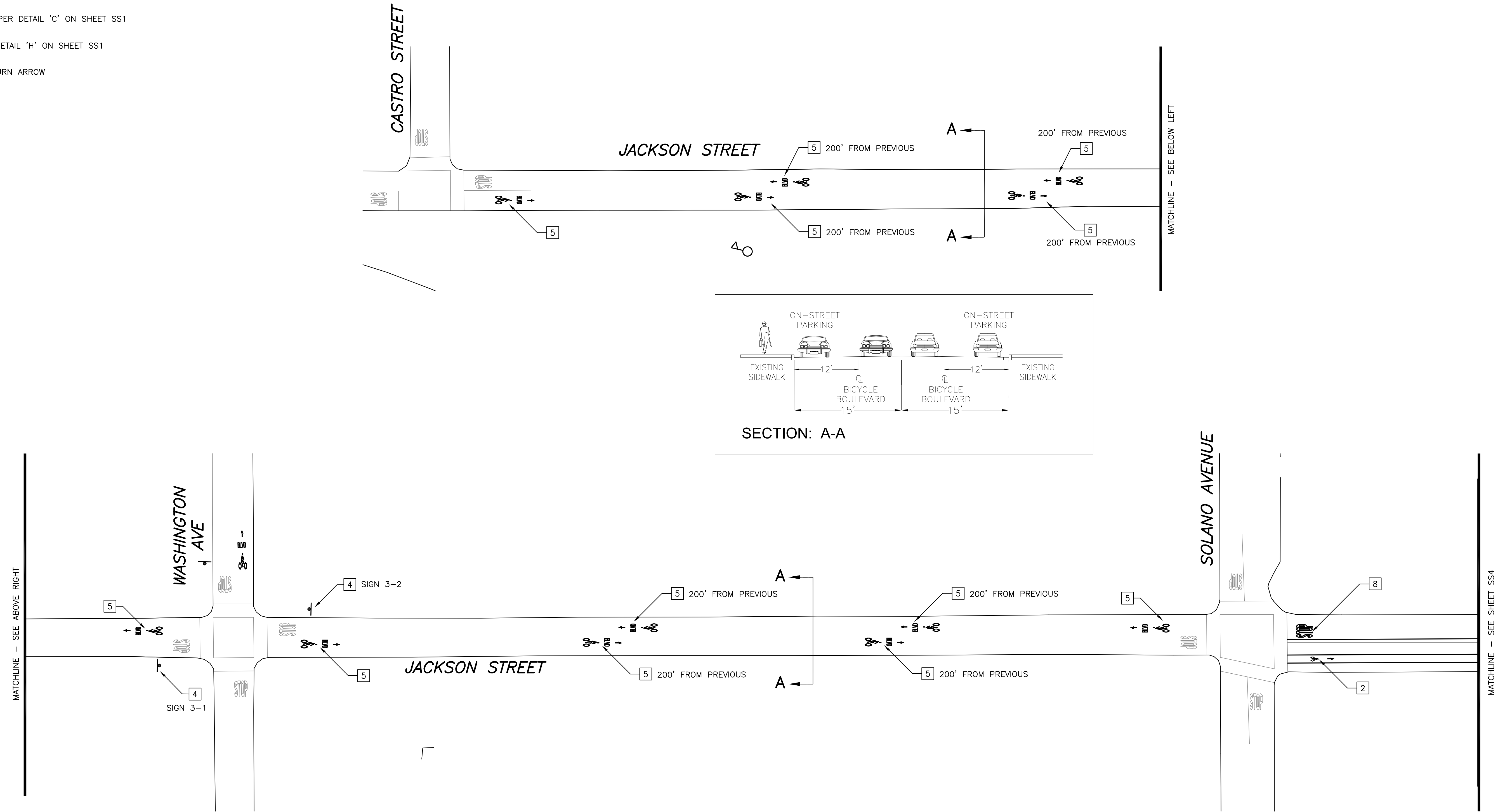
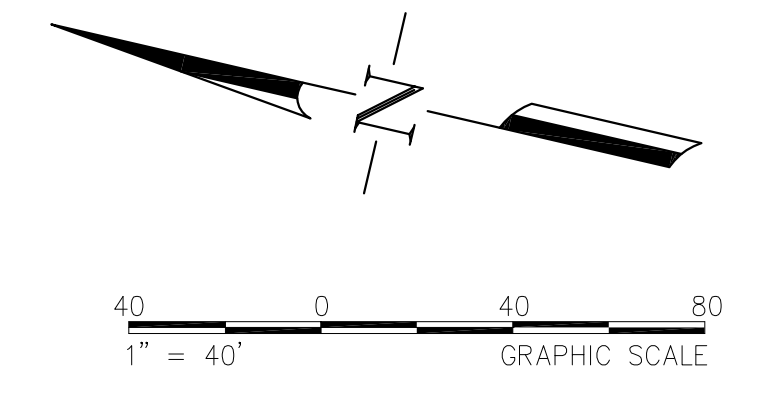

Nov 07, 2014 CADD FILE: N:\PROJECTS\WC13\WC13-3073\Albany_ATP_Signage\Signage\CAD\65_Submit\3073-SS1_SS8-ATP_3-15.dwg

REVISIONS			
NO.	DESCRIPTION	DATE	BY

FEHR PEERS
 100 Pringle Avenue Walnut Creek, CA 94596
 Suite 600 (925) 930-7100

Walnut Creek, CA San Diego, CA
 Roseville, CA Oakland, CA
 San Jose, CA Salt Lake City, UT
 San Francisco, CA Reno, NV
 Orange County, CA Denver, CO
 Los Angeles County, CA Seattle, WA



Designed By: PS/RM
 Drawn By: PS/DD
 Checked By: RM
 Drawing No.: WC13-3073
 Date: 11/07/2014

ALBANY ACTIVE TRANSPORTATION PLAN
 ATP PROJECT #5 - JACKSON STREET
 SIGNING & STRIPING PLAN

SHEET
 SS3
 OF
 23

Fehr & Peers Associates, its employees, its officers or agents shall not be responsible for the accuracy or completeness of electronic copies of this plan sheet.

PROJECT NOTES (THIS SHEET ONLY):

- 1 INSTALL SHARROW PER DETAIL 'A' ON SHEET SS1.
- 2 INSTALL BIKE LANE STENCIL PER DETAIL 'B' ON SHEET SS1
- 3 INSTALL BICYCLE BOX PER DETAIL 'D' ON SHEET SS1
- 4 INSTALL GUIDE SIGN PER DETAIL 'E' ON SHEET SS1. SEE SHEET SS21 FOR SIGN TEXT.
- 5 INSTALL BIKE BOULEVARD STENCIL PER DETAIL 'C' ON SHEET SS1
- 6 INSTALL MODIFIED DETAIL 21 PER DETAIL 'H' ON SHEET SS1
- 7 INSTALL BICYCLE LOOP DETECTOR SYMBOL PER DETAIL 'F' ON SHEET SS1
- 8 INSTALL STOP LEGEND
- 9 CONVERT EXISTING PARKING TO BACK-IN ANGLED PARKING

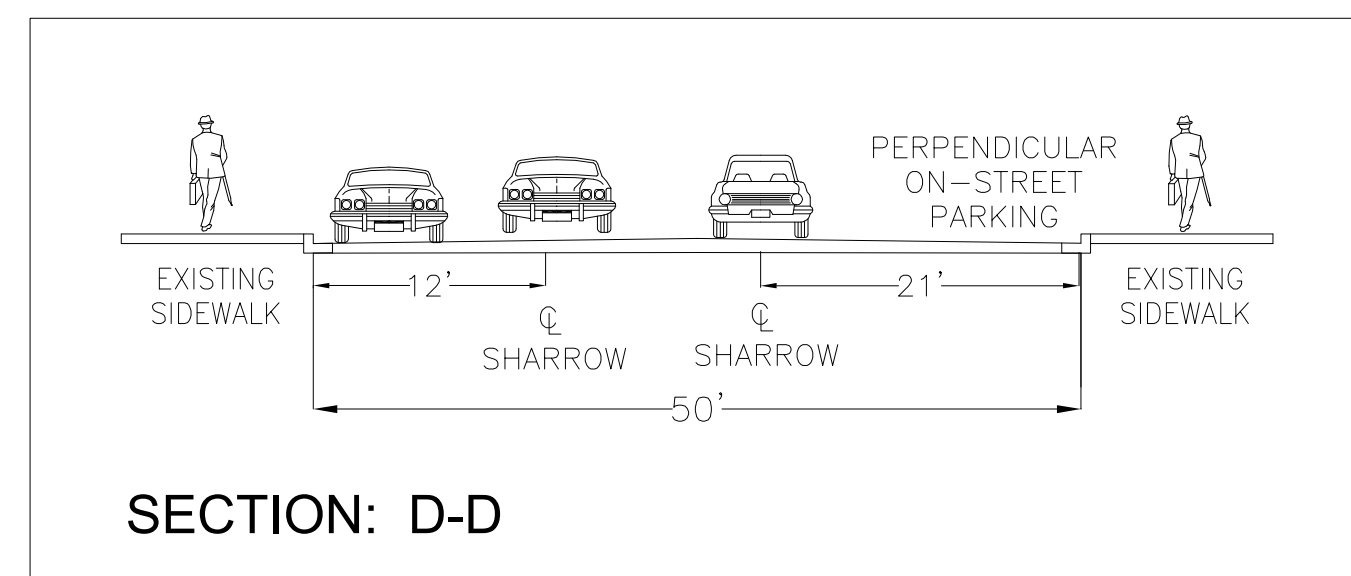
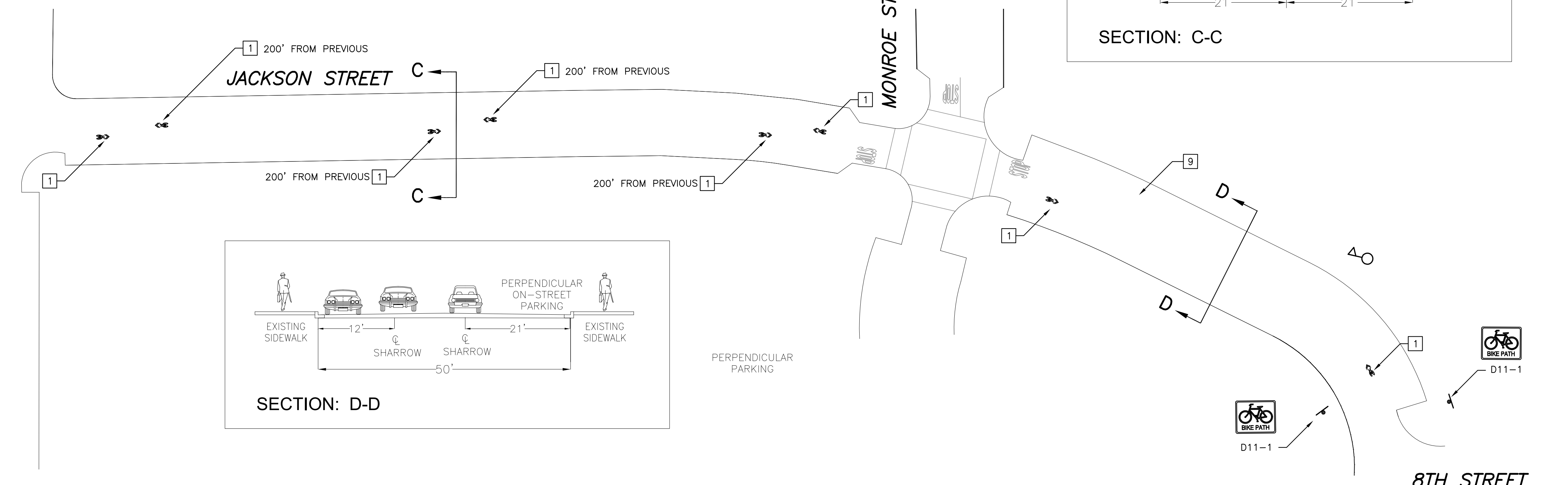
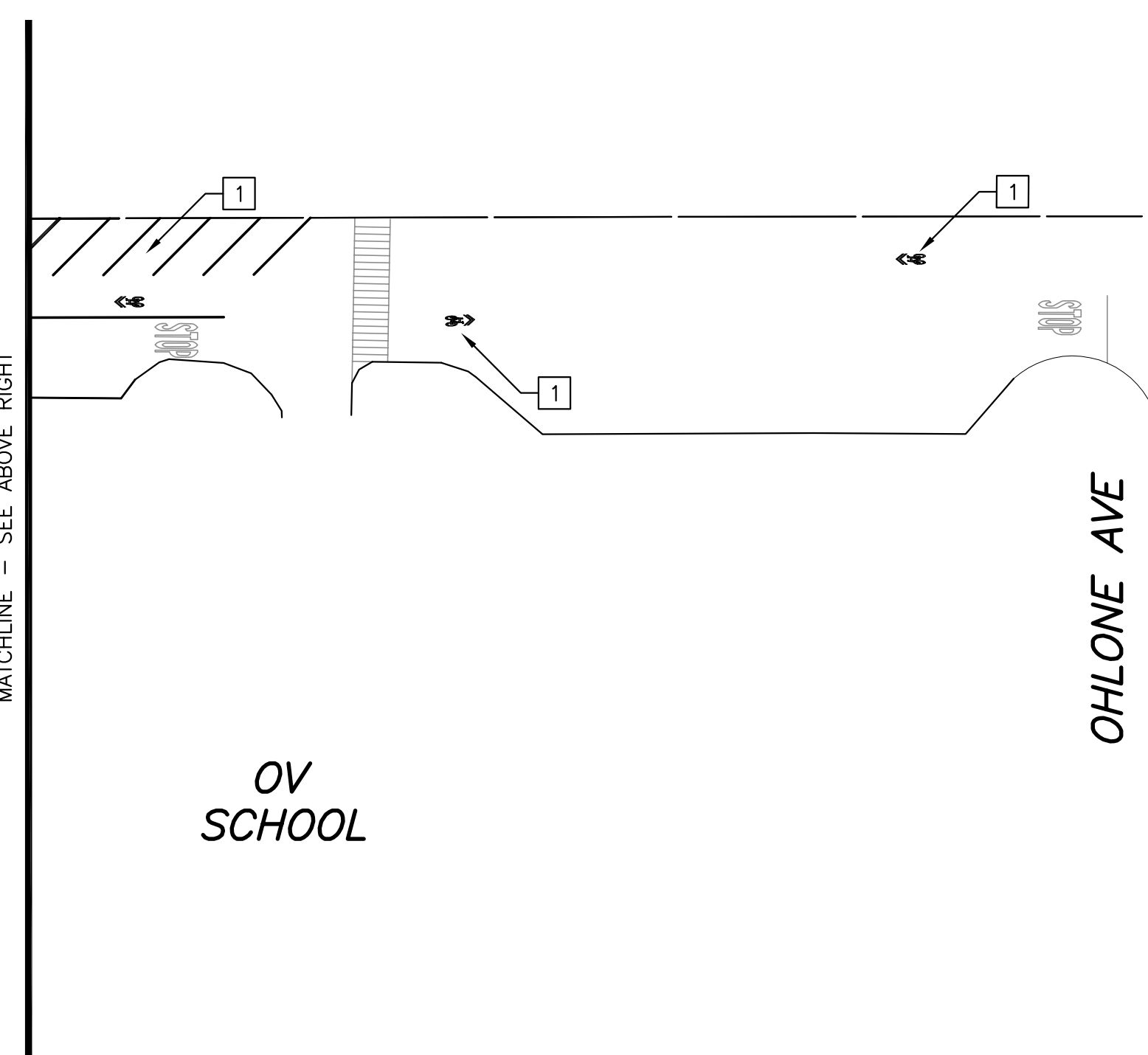
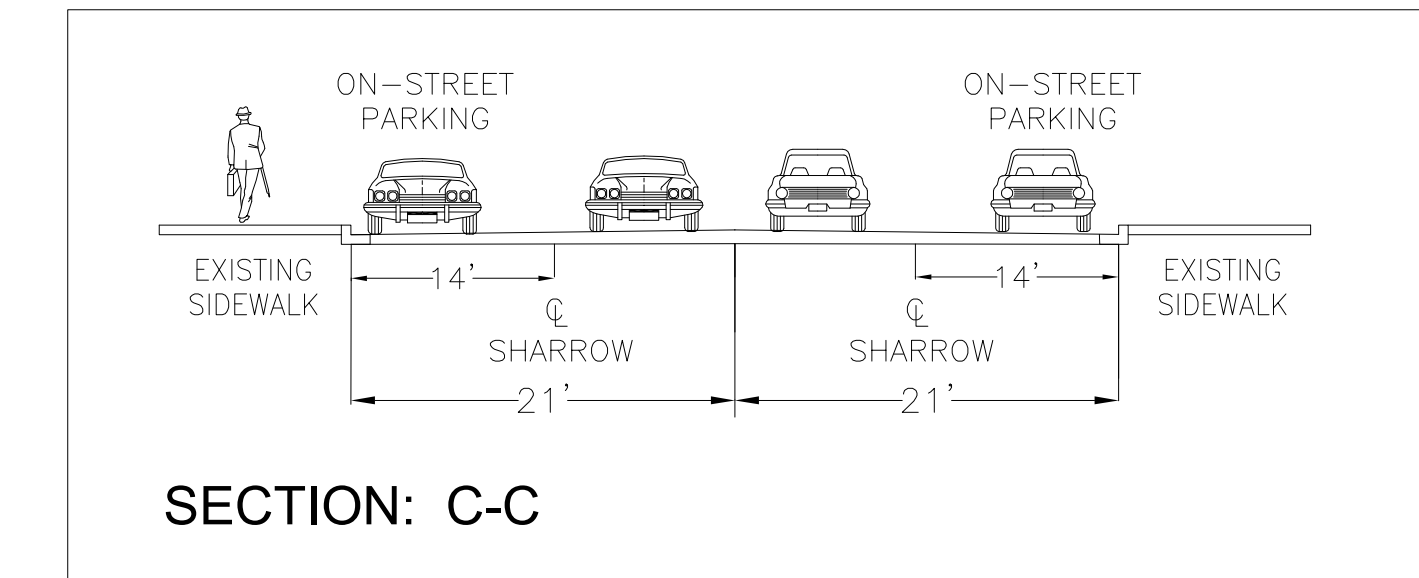
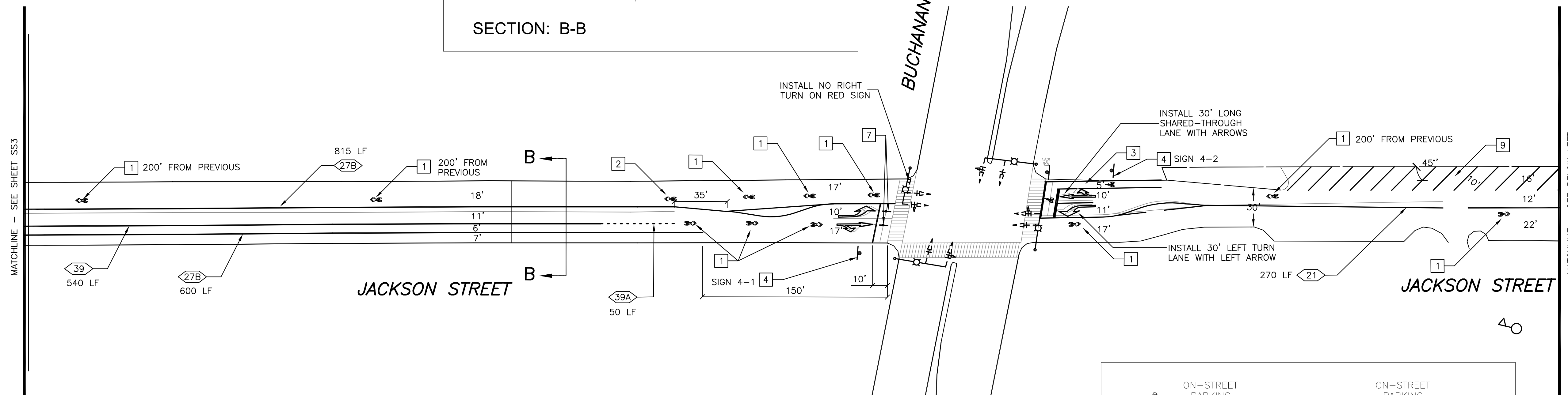
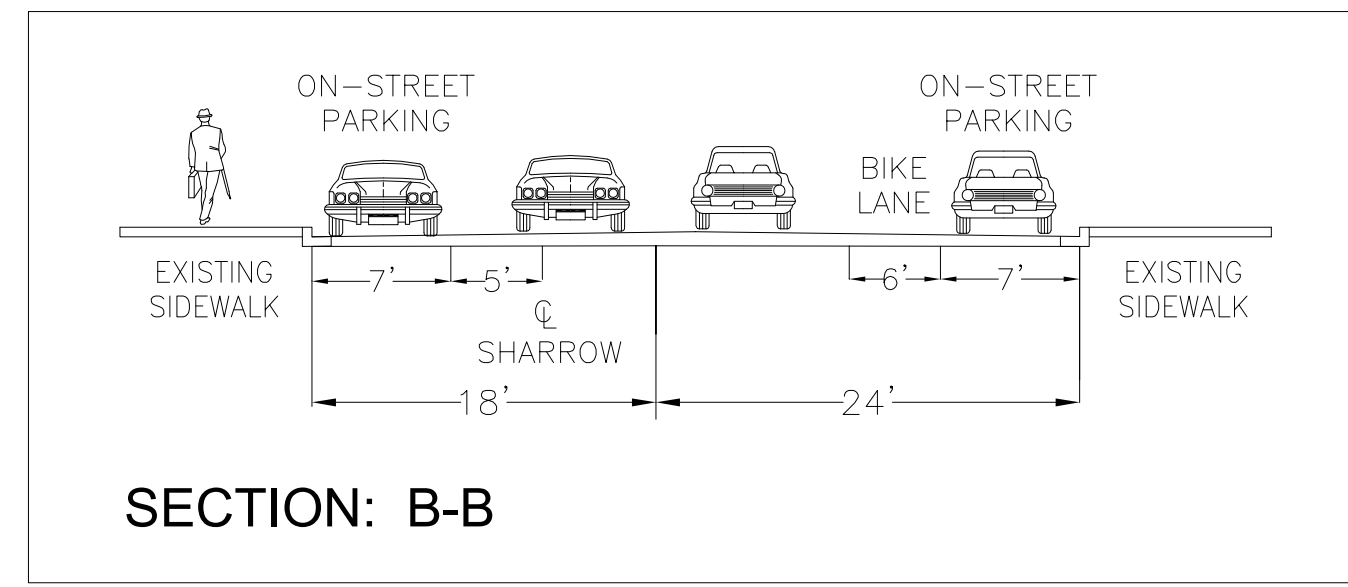
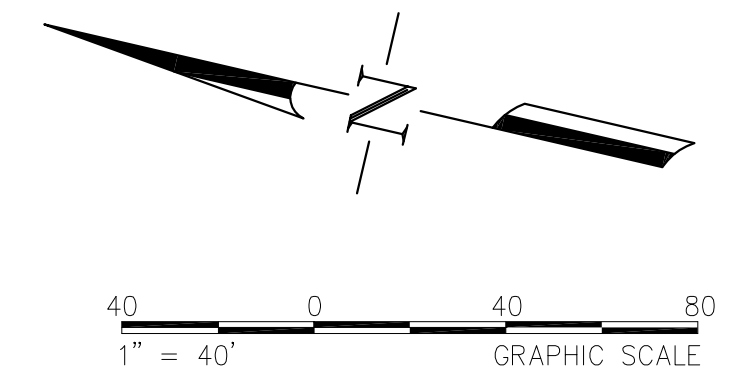

Nov 07, 2014 CADD FILE: N:\PROJECTS\WC13\WC13-3073-Albany_ATP_Signing-Striping-Storage\CAD\65_Submittal\3073-SS1_SS8-ATP_3-15.dwg

REVISIONS			
NO.	DESCRIPTION	DATE	BY

FEHR PEERS

100 Pringle Avenue Walnut Creek, CA 94596
Suite 600 (925) 930-7100

Walnut Creek, CA San Diego, CA
 Roseville, CA Oakland, CA
 San Jose, CA Salt Lake City, UT
 San Francisco, CA Reno, NV
 Orange County, CA Denver, CO
 Los Angeles County, CA Seattle, WA



Designed By: PS/RM
 Drawn By: PS/DD
 Checked By: RM
 Drawing No.: WC13-3073
 Date: 11/07/2014

ALBANY ACTIVE TRANSPORTATION PLAN
 ATP PROJECT #5 - JACKSON STREET
 SIGNING & STRIPING PLAN

SHEET
 SS4
 OF
 23

Fehr & Peers Associates, its employees, its officers or agents shall not be responsible for the accuracy or completeness of electronic copies of this plan sheet.

PROJECT NOTES (THIS SHEET ONLY):

- 1 INSTALL SHARROW PER DETAIL 'A' ON SHEET SS1.
- 2 INSTALL BIKE LANE STENCIL PER DETAIL 'B' ON SHEET SS1
- 3 INSTALL BICYCLE BOX PER DETAIL 'D' ON SHEET SS1
- 4 INSTALL GUIDE SIGN PER DETAIL 'E' ON SHEET SS1. SEE SHEET SS21 FOR SIGN TEXT.
- 5 INSTALL BIKE BOULEVARD STENCIL PER DETAIL 'C' ON SHEET SS1
- 6 INSTALL MODIFIED DETAIL 21 PER DETAIL 'H' ON SHEET SS1
- 7 INSTALL BIKE LEGEND WITH LEFT TURN ARROW
- 8 INSTALL STOP LEGEND

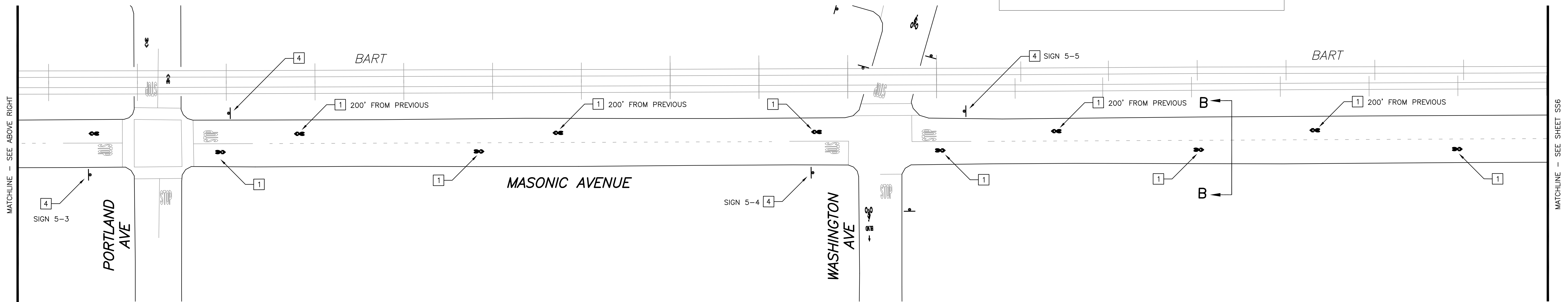
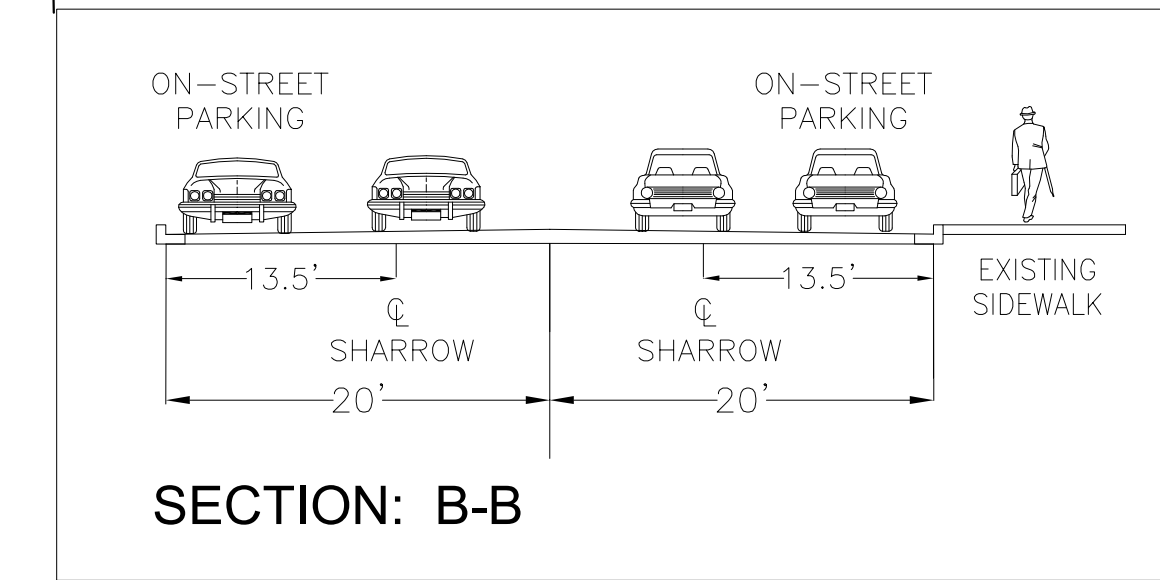
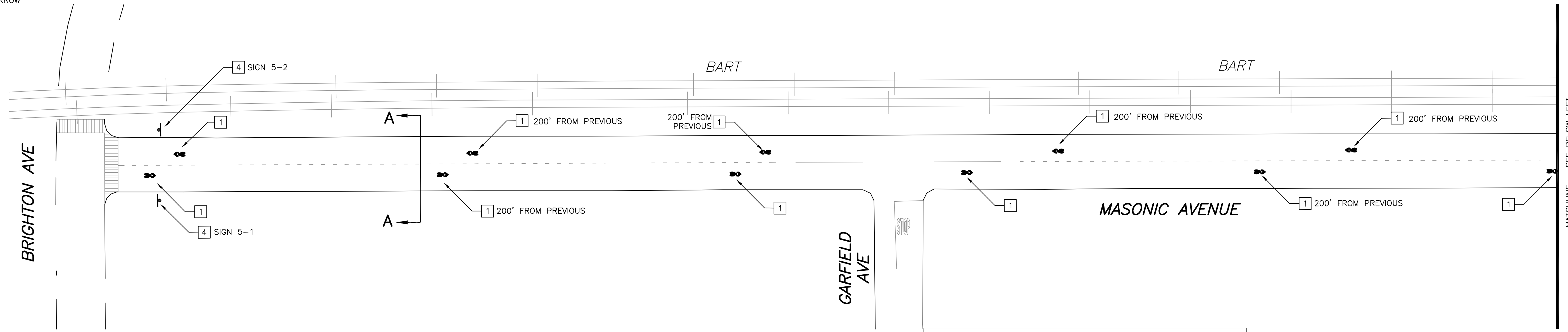
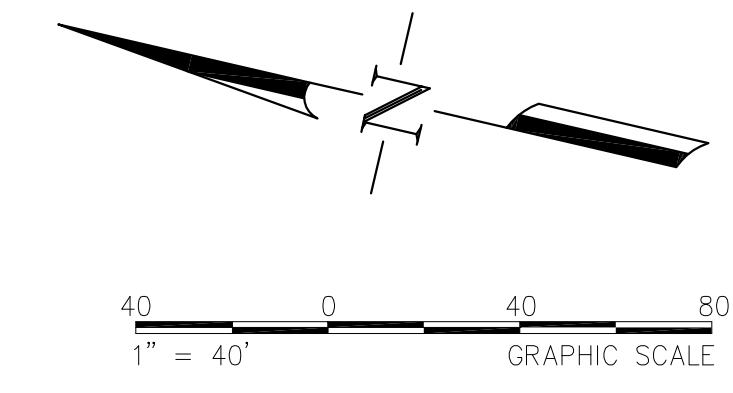
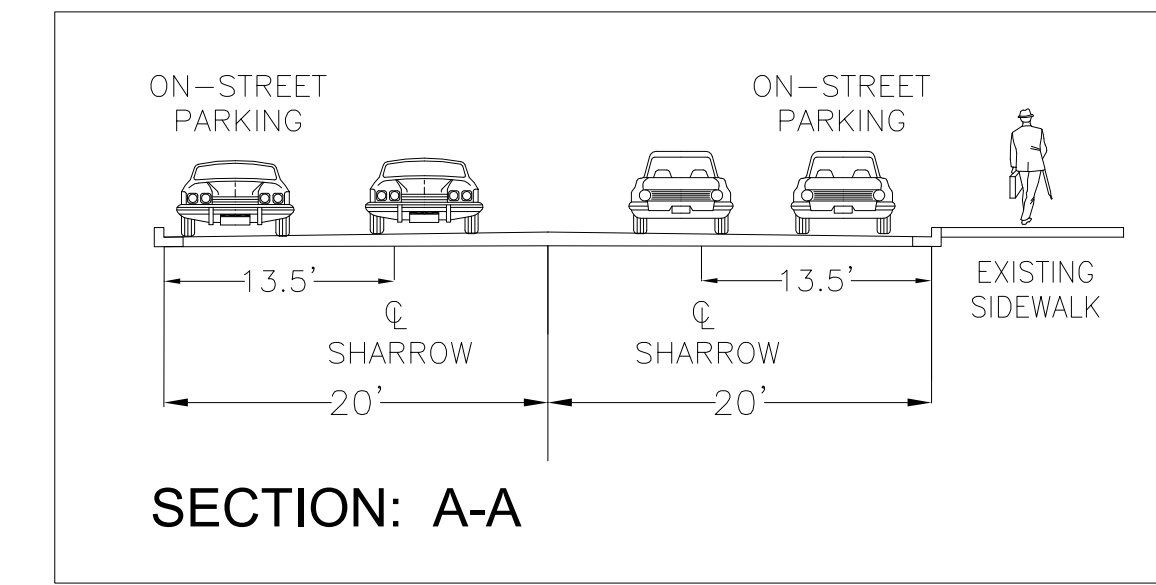

Nov 07, 2014 CADD FILE: N:\PROJECTS\WC13\WC13-3073-Albany_ATP_Signing-Striping-Signage\CAD\65_Submital\3073-SS1_SSB-ATP_3-15.dwg

REVISIONS			
NO.	DESCRIPTION	DATE	BY

FEHR PEERS
 100 Pringle Avenue Walnut Creek, CA 94596
 Suite 600 (925) 930-7100

Walnut Creek, CA San Diego, CA
 Roseville, CA Oakland, CA
 San Jose, CA Salt Lake City, UT
 San Francisco, CA Reno, NV
 Orange County, CA Denver, CO
 Los Angeles County, CA Seattle, WA



Designed By: PS/RM
 Drawn By: PS/DD
 Checked By: RM
 Drawing No.: WC13-3073
 Date: 11/07/2014

ALBANY ACTIVE TRANSPORTATION PLAN
 ATP PROJECT #7 - MASONIC AVENUE
 (BRIGHTON AVE to WASHINGTON AVE)
 SIGNING & STRIPING PLAN

SHEET
 SS5
 OF
 23

Fehr & Peers Associates, its employees, its officers or agents shall not be responsible for the accuracy or completeness of electronic copies of this plan sheet.

PROJECT NOTES (THIS SHEET ONLY):

- 1 INSTALL SHARROW PER DETAIL 'A' ON SHEET SS1.
- 2 INSTALL BIKE LANE STENCIL PER DETAIL 'B' ON SHEET SS1
- 3 INSTALL BICYCLE BOX PER DETAIL 'D' ON SHEET SS1
- 4 INSTALL GUIDE SIGN PER DETAIL 'E' ON SHEET SS1. SEE SHEET SS21 FOR SIGN TEXT.
- 5 INSTALL BIKE BOULEVARD STENCIL PER DETAIL 'C' ON SHEET SS1
- 6 INSTALL MODIFIED DETAIL 21 PER DETAIL 'H' ON SHEET SS1
- 7 INSTALL BICYCLE LOOP DETECTOR SYMBOL PER DETAIL 'F' ON SHEET SS1

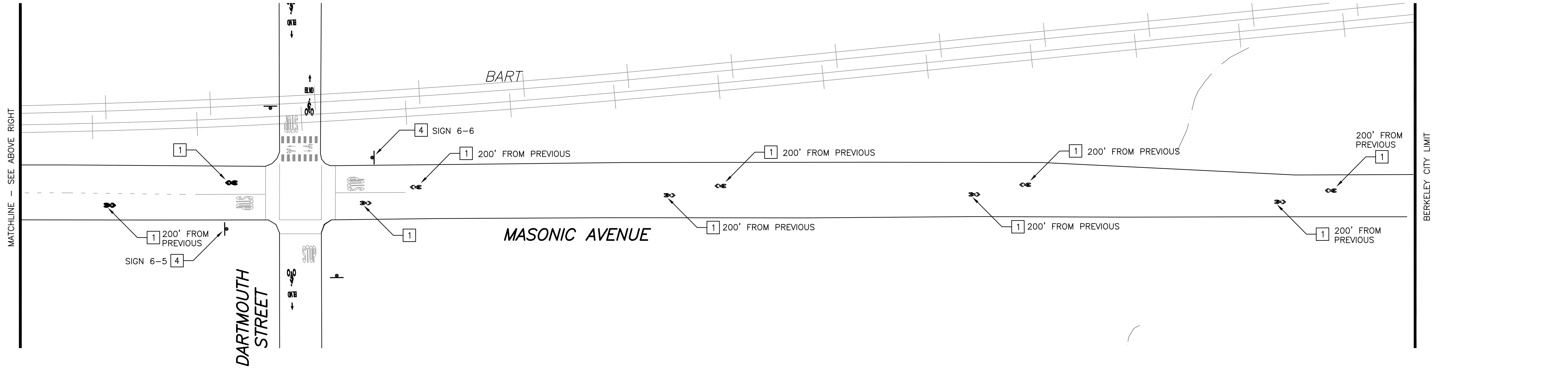
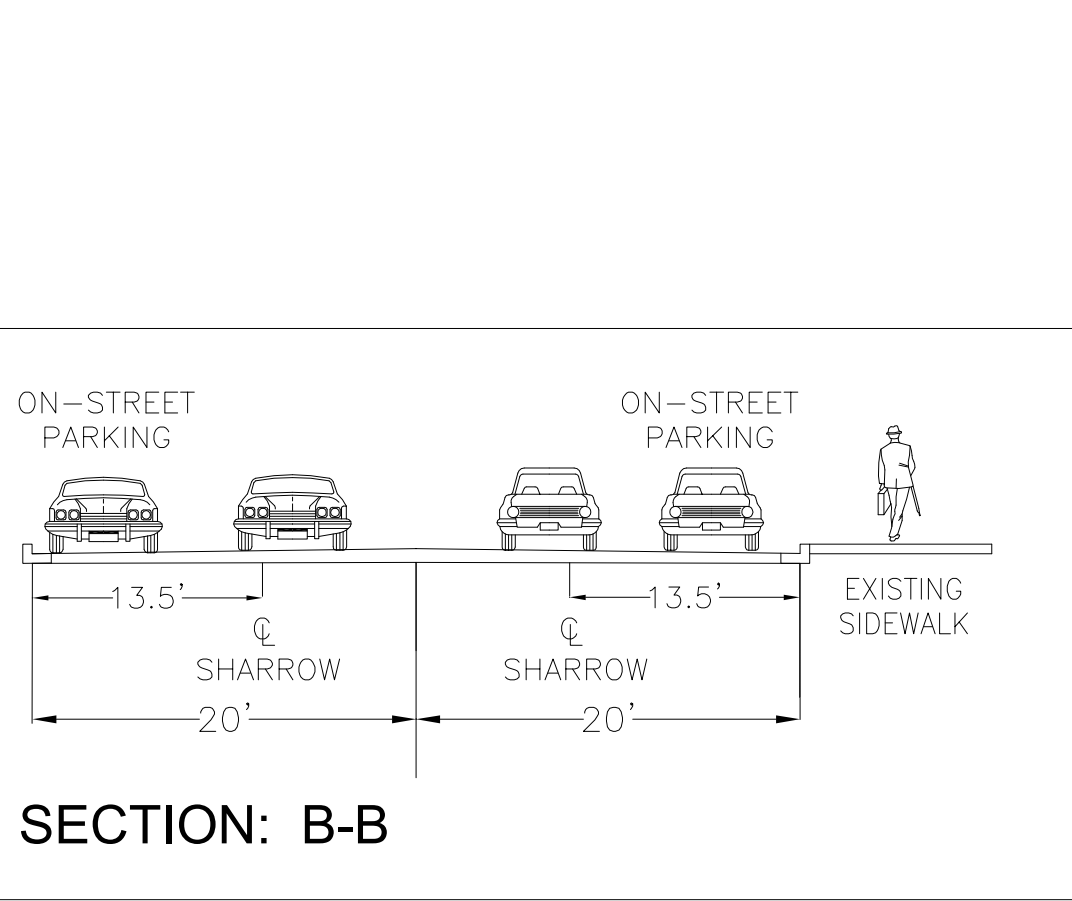
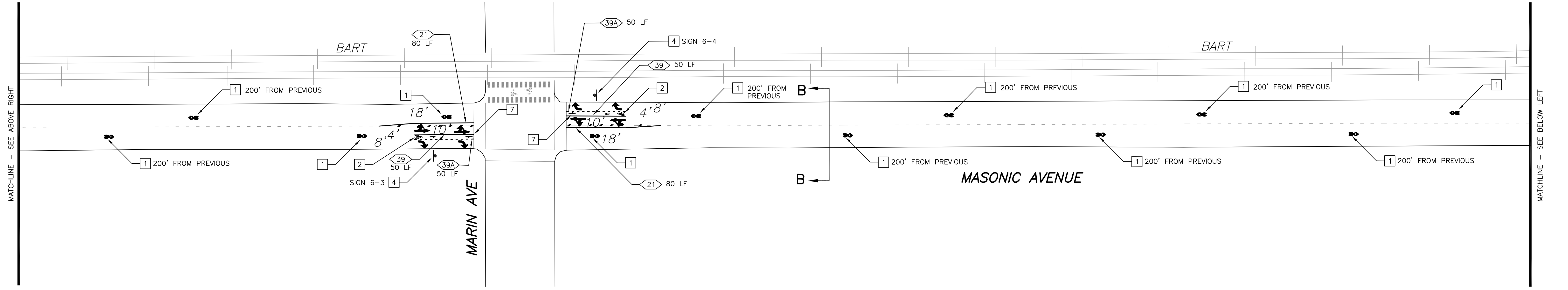
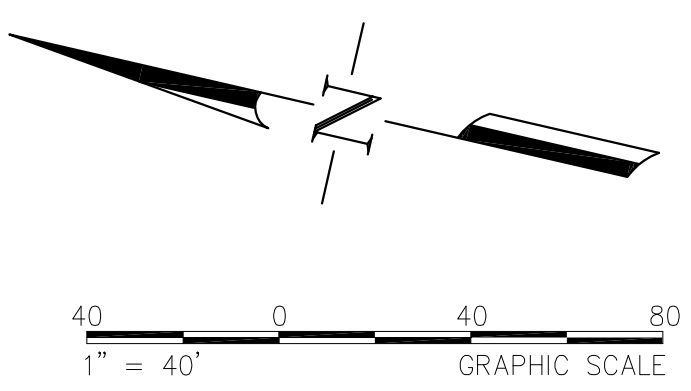
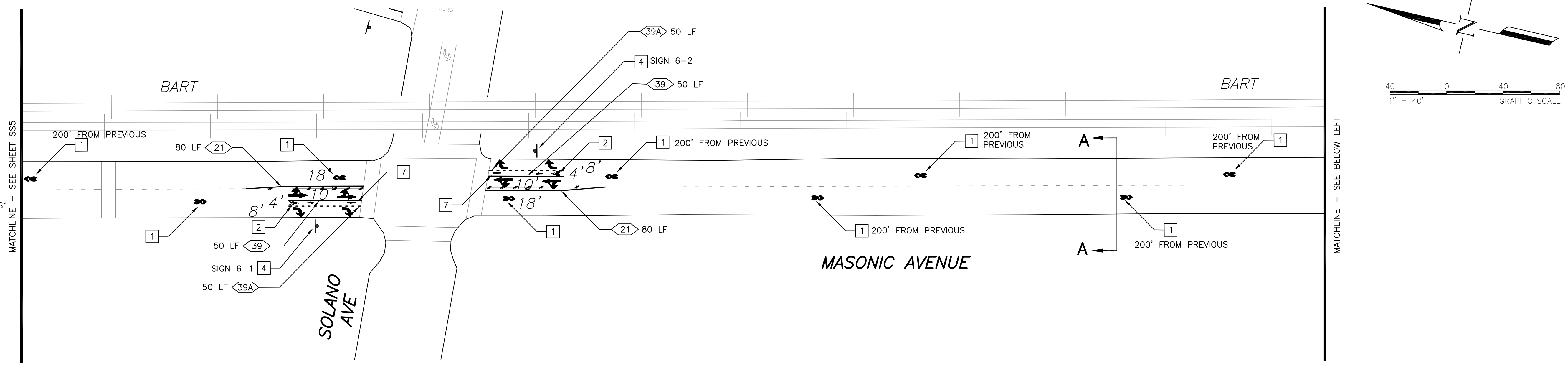
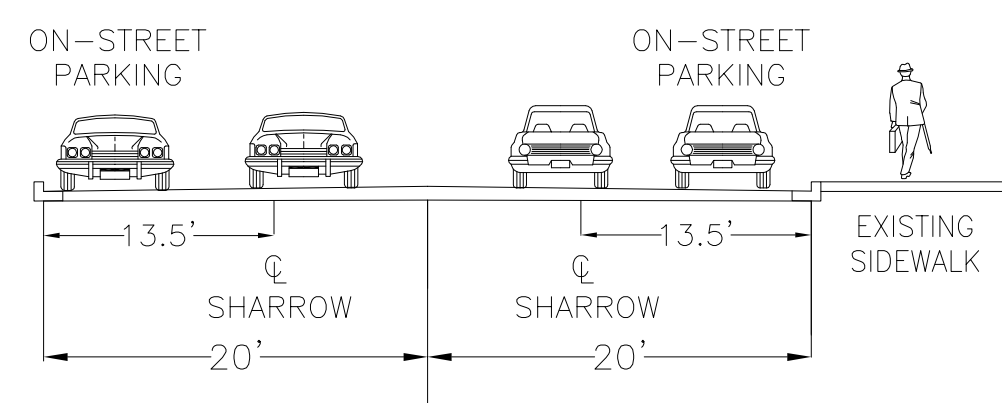

NO.	DESCRIPTION	DATE	BY

FEHR & PEERS
 100 Pringle Avenue Walnut Creek, CA 94596
 Suite 600 (925) 930-7100

Walnut Creek, CA San Diego, CA
 Roseville, CA Oakland, CA
 San Jose, CA Salt Lake City, UT
 San Francisco, CA Reno, NV
 Orange County, CA Denver, CO
 Los Angeles County, CA Seattle, WA



Designed By: PS/RM
 Drawn By: PS/DD
 Checked By: RM
 Drawing No.: WC13-3073
 Date: 11/07/2014

ALBANY ACTIVE TRANSPORTATION PLAN
 ATP PROJECT #7 - MASONIC AVENUE
 (SOLANO AVE to DARTMOUTH ST)
 SIGNING & STRIPING PLAN

SHEET
 SS6
 OF
 23

Nov 07, 2014 CADD FILE: N:\PROJECTS\WC13\WC13-3073\Striping\Signage\CAD\65_Submittal\3073-SS1_SS8-ATP_3-15.dwg

Fehr & Peers Associates, its employees, its officers or agents shall not be responsible for the accuracy or completeness of electronic copies of this plan sheet.

PROJECT NOTES (THIS SHEET ONLY):

- 1 INSTALL SHARROW PER DETAIL 'A' ON SHEET SS1.
- 2 INSTALL BIKE LANE STENCIL PER DETAIL 'B' ON SHEET SS1
- 3 INSTALL BICYCLE BOX PER DETAIL 'D' ON SHEET SS1
- 4 INSTALL GUIDE SIGN PER DETAIL 'E' ON SHEET SS1. SEE SHEET SS21 FOR SIGN TEXT.
- 5 INSTALL BIKE BOULEVARD STENCIL PER DETAIL 'C' ON SHEET SS1
- 6 INSTALL MODIFIED DETAIL 21 PER DETAIL 'H' ON SHEET SS1
- 7 INSTALL WHITE CROSSWALK
- 8 INSTALL STOP LEGEND
- 9 INSTALL DELINEATORS AT 5' ON CENTER

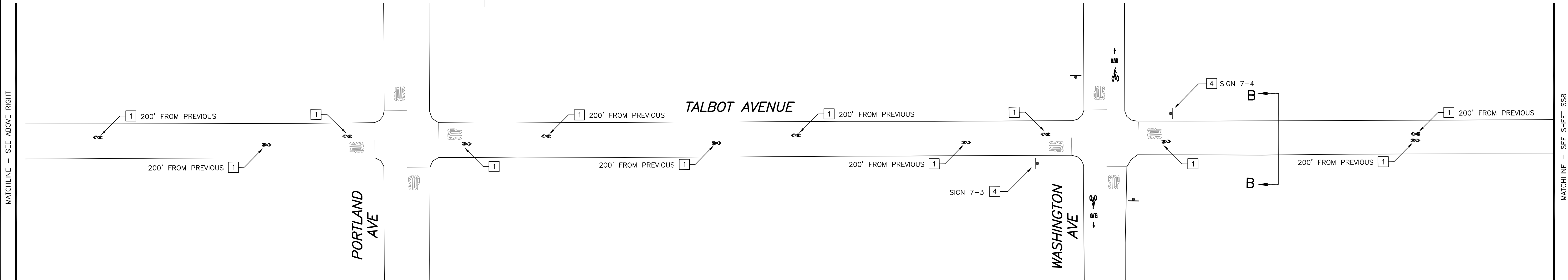
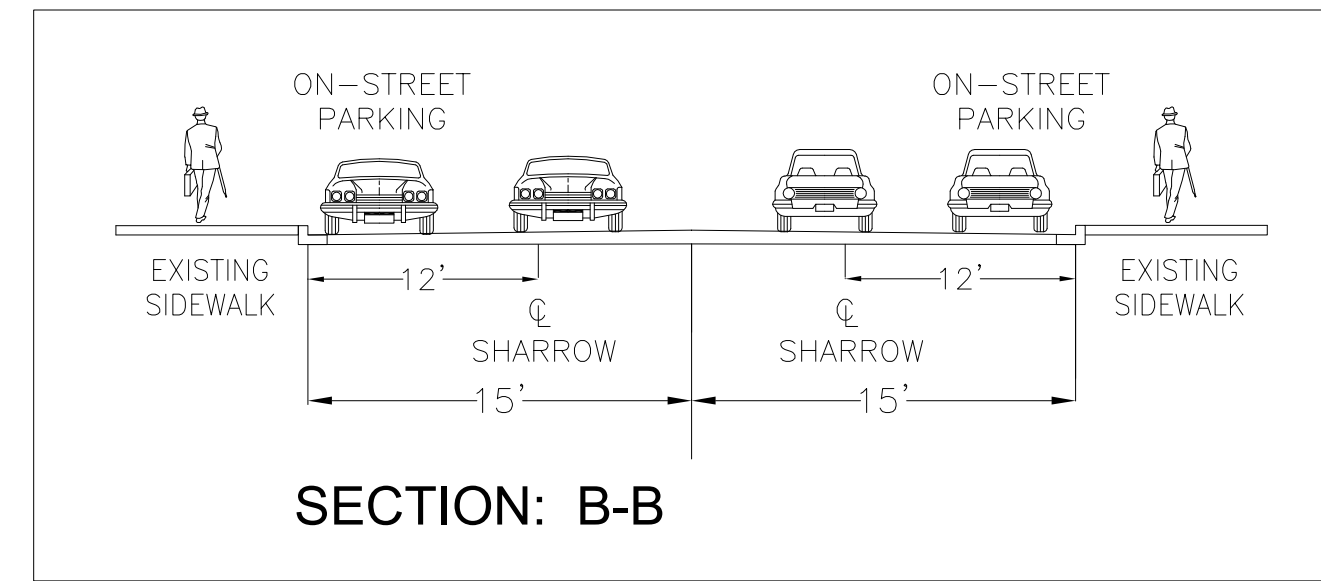
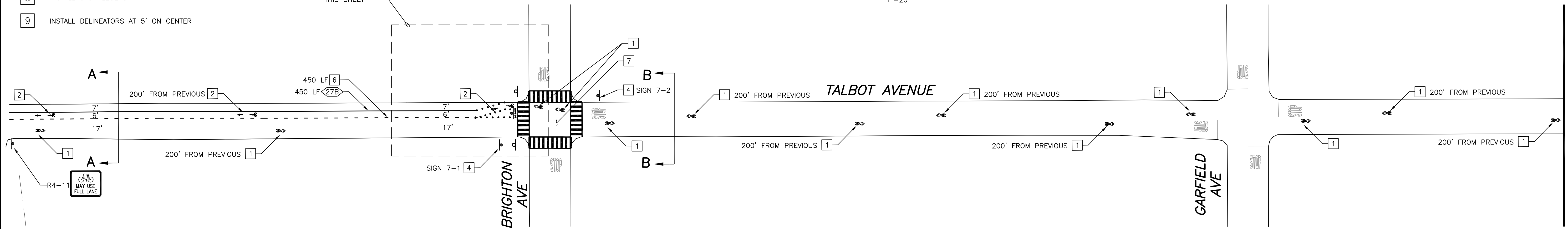
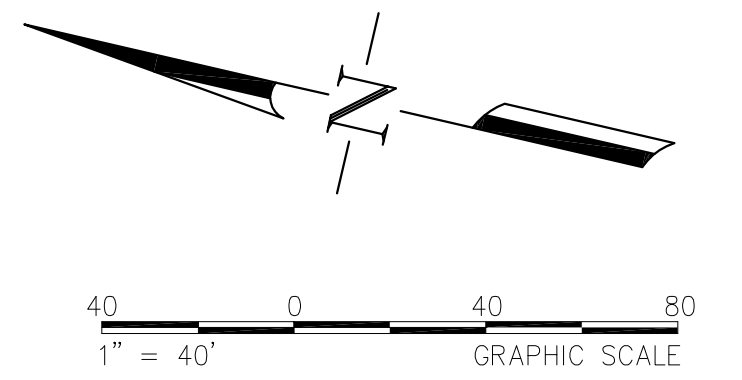
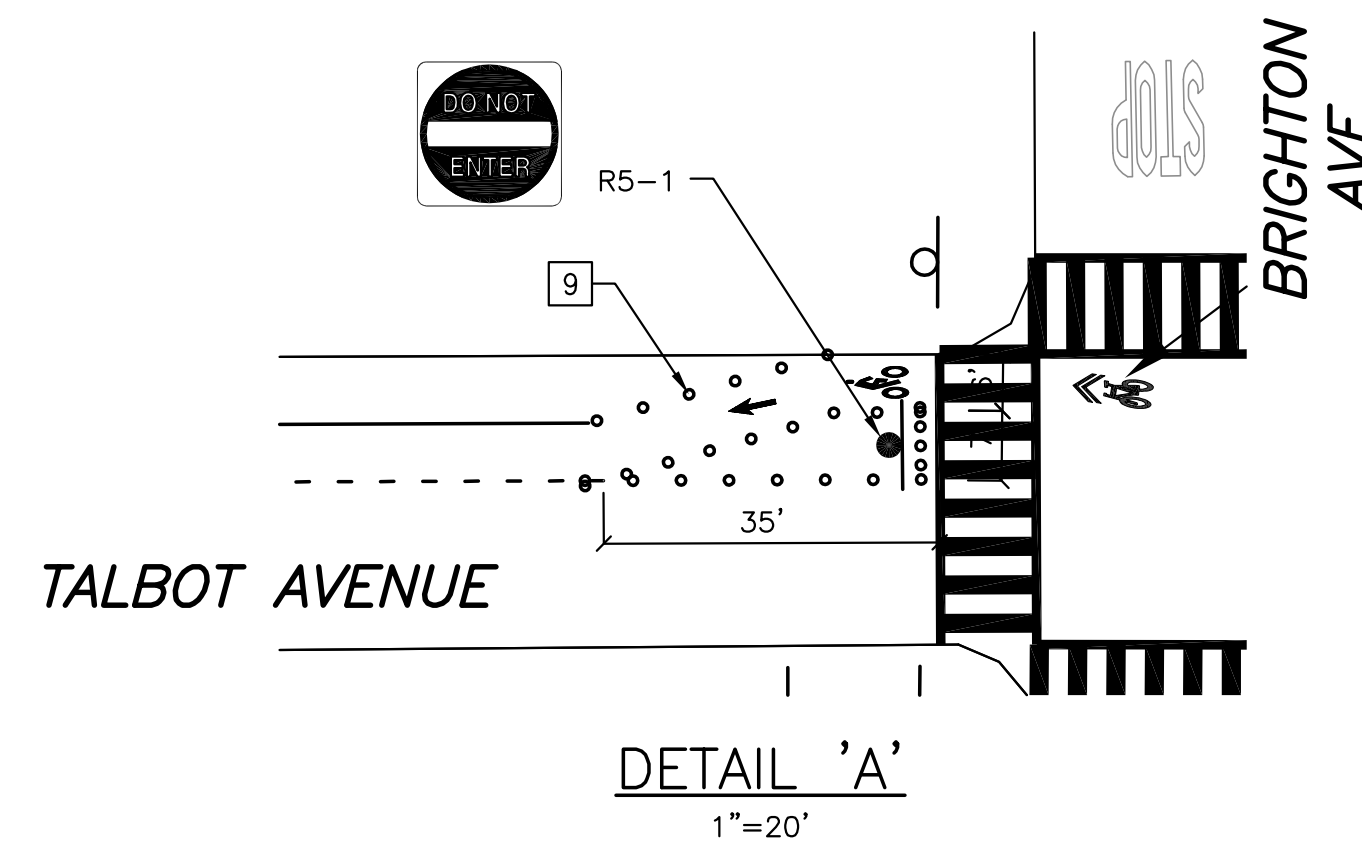
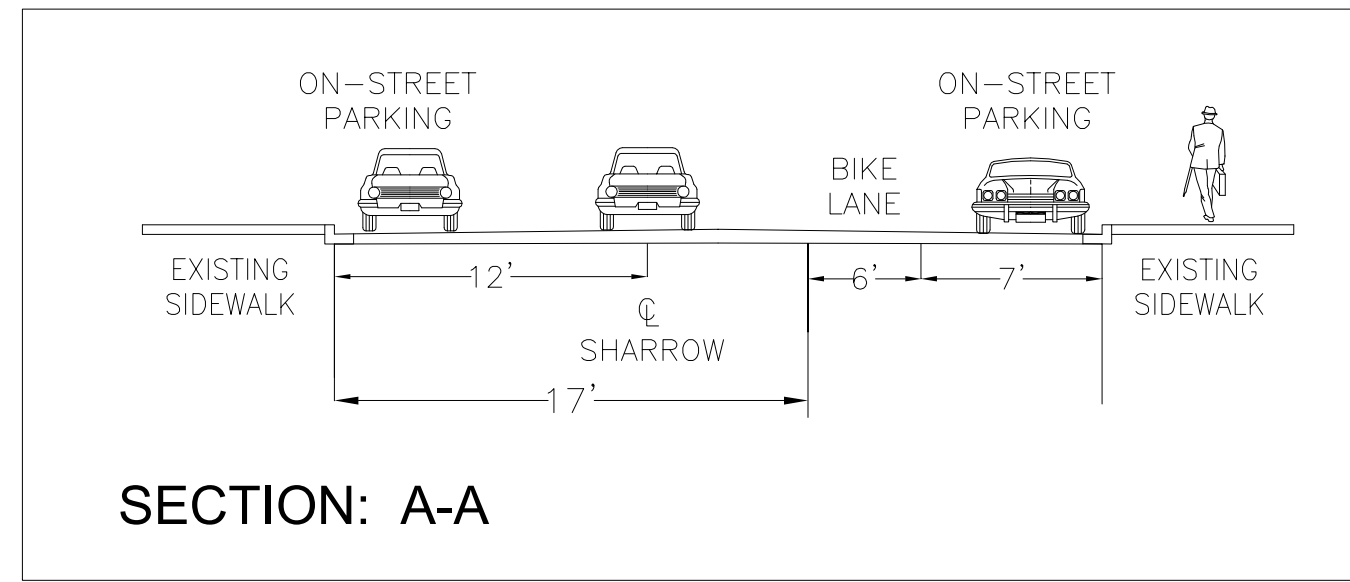

REVISIONS

NO.	DESCRIPTION	DATE	BY

FEHR PEERS
100 Pringle Avenue Walnut Creek, CA 94596
Suite 600 (925) 930-7100

- Walnut Creek, CA
- Roseville, CA
- San Jose, CA
- San Francisco, CA
- Orange County, CA
- Los Angeles County, CA
- San Diego, CA
- Oakland, CA
- Salt Lake City, UT
- Reno, NV
- Denver, CO
- Seattle, WA



Designed By: PS/RM
 Drawn By: PS/DD
 Checked By: RM
 Drawing No.: WC13-3073
 Date: 11/07/2014

ALBANY ACTIVE TRANSPORTATION PLAN

ATP PROJECT #8 - TALBOT AVENUE
(BRIGHTON AVE to WASHINGTON AVE)

SIGNING & STRIPING PLAN

SHEET
SS7
— OF —
23

Nov 07, 2014 CADD FILE: N:\PROJECTS\WC13\WC13-3073\Albany_ATP_Signing-Striping-Signage\CAD\65_Submittal\3073-SS1_SS8-ATP_3-15.dwg

Fehr & Peers Associates, its employees, its officers or agents shall not be responsible for the accuracy or completeness of electronic copies of this plan sheet.

PROJECT NOTES (THIS SHEET ONLY):

- 1 INSTALL SHARROW PER DETAIL 'A' ON SHEET SS1.
- 2 INSTALL BIKE LANE STENCIL PER DETAIL 'B' ON SHEET SS1
- 3 INSTALL BICYCLE BOX PER DETAIL 'D' ON SHEET SS1
- 4 INSTALL GUIDE SIGN PER DETAIL 'E' ON SHEET SS1. SEE SHEET SS21 FOR SIGN TEXT.
- 5 INSTALL BIKE BOULEVARD STENCIL PER DETAIL 'C' ON SHEET SS1

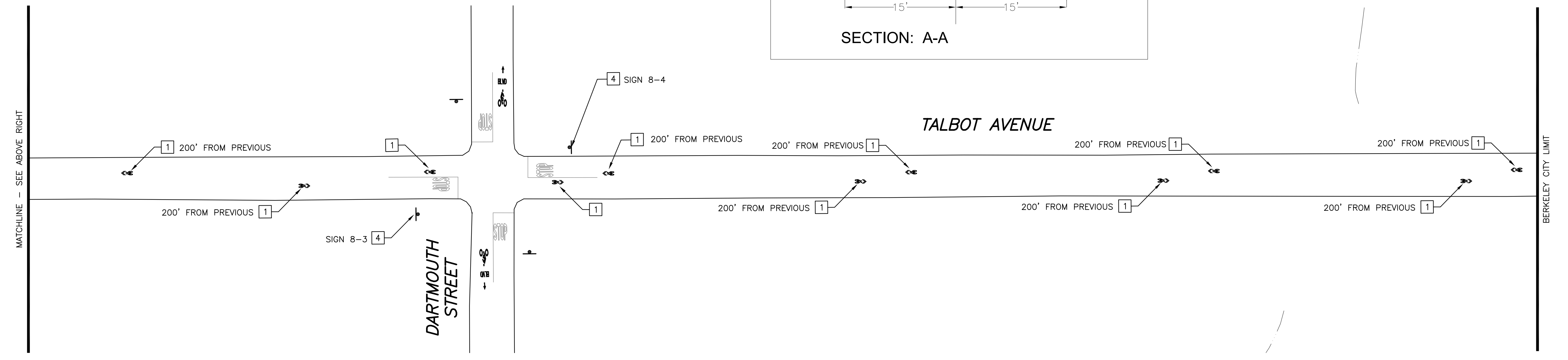
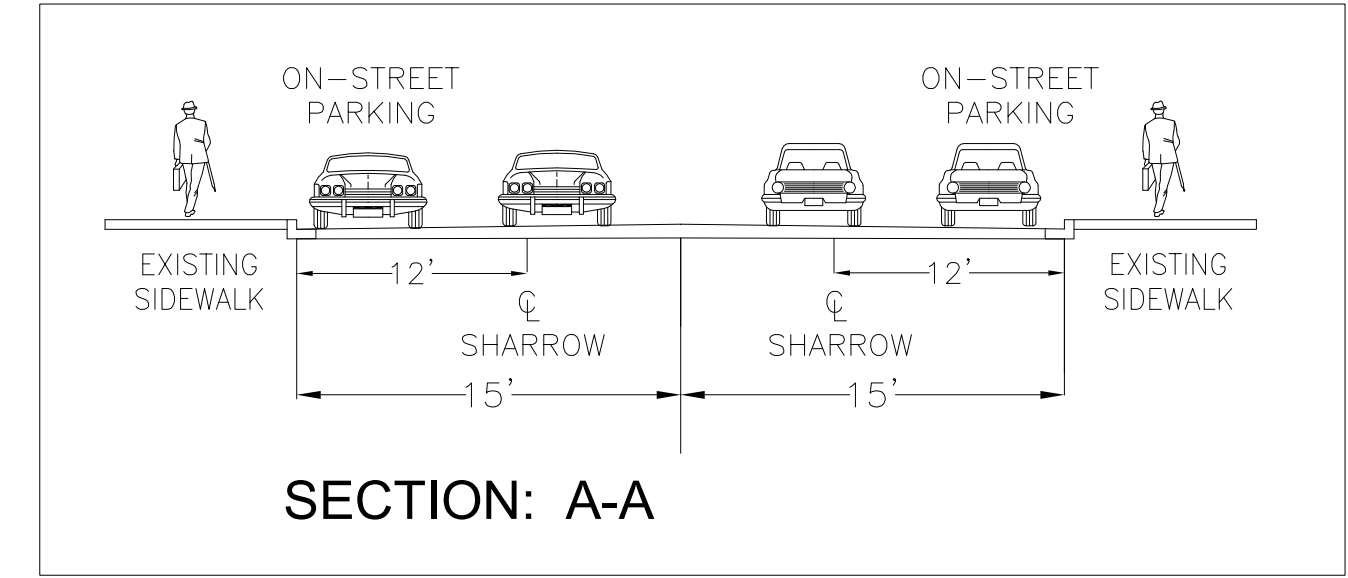
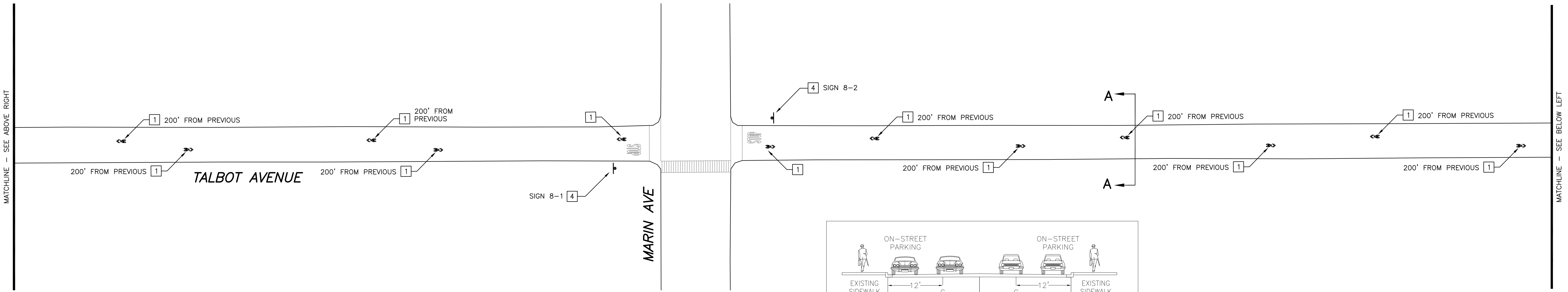
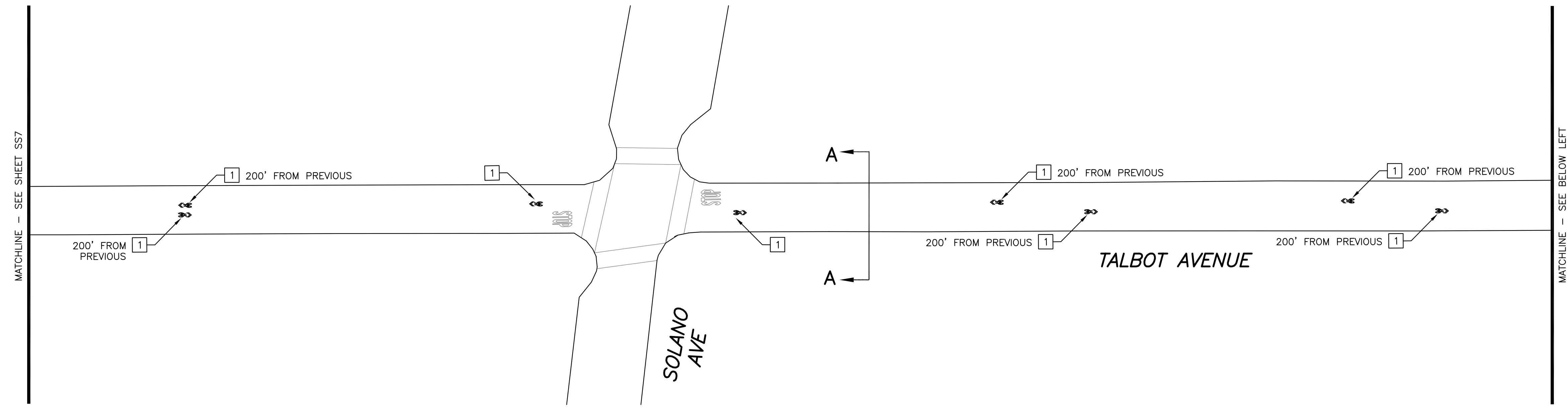
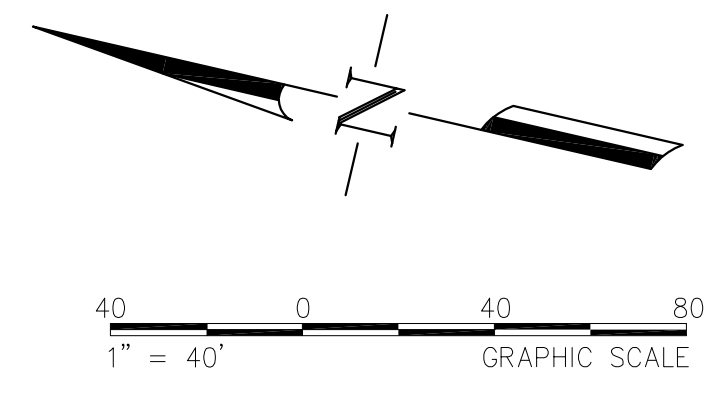

Nov 07, 2014 CADD FILE: N:\PROJECTS\WC13\WC13-3073\Albany_ATP_Signing_Striping\Signage\CAD\65_Submital\3073-SS1_SS8-ATP_3-15.dwg

REVISIONS			
NO.	DESCRIPTION	DATE	BY

FEHR PEERS

100 Pringle Avenue Walnut Creek, CA 94596
(925) 930-7100

- Walnut Creek, CA
- San Diego, CA
- Roseville, CA
- Oakland, CA
- San Jose, CA
- Salt Lake City, UT
- San Francisco, CA
- Reno, NV
- Orange County, CA
- Denver, CO
- Los Angeles County, CA
- Seattle, WA



Designed By: PS/RM
 Drawn By: PS/DD
 Checked By: RM
 Drawing No.: WC13-3073
 Date: 11/07/2014

ALBANY ACTIVE TRANSPORTATION PLAN

ATP PROJECT #8 - TALBOT AVENUE
 (SOLANO AVE to DARTMOUTH ST)

SIGNING & STRIPING PLAN

SHEET
SS8
— OF —
23

Fehr & Peers Associates, its employees, its officers or agents shall not be responsible for the accuracy or completeness of electronic copies of this plan sheet.

PROJECT NOTES (THIS SHEET ONLY):

- 1 INSTALL SHARROW PER DETAIL 'A' ON SHEET SS1.
- 2 INSTALL BIKE LANE STENCIL PER DETAIL 'B' ON SHEET SS1
- 3 INSTALL BICYCLE BOX PER DETAIL 'D' ON SHEET SS1
- 4 INSTALL GUIDE SIGN PER DETAIL 'E' ON SHEET SS1. SEE SHEET SS21 FOR SIGN TEXT.
- 5 INSTALL BIKE BOULEVARD STENCIL PER DETAIL 'C' ON SHEET SS1
- 6 INSTALL TRAFFIC CIRCLE PER DETAIL ON SHEET SS23

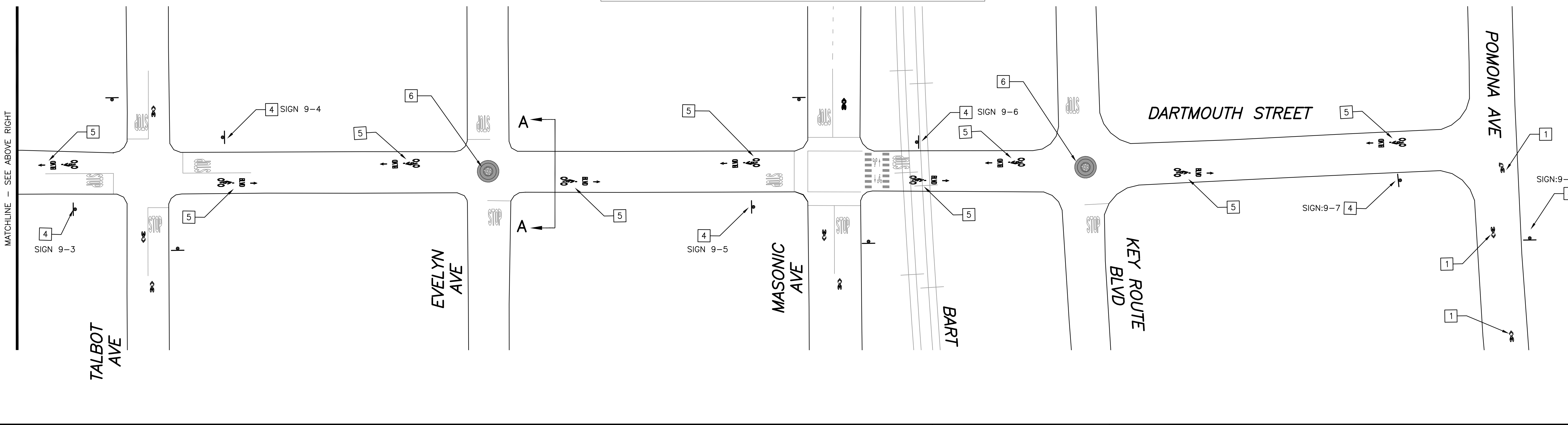
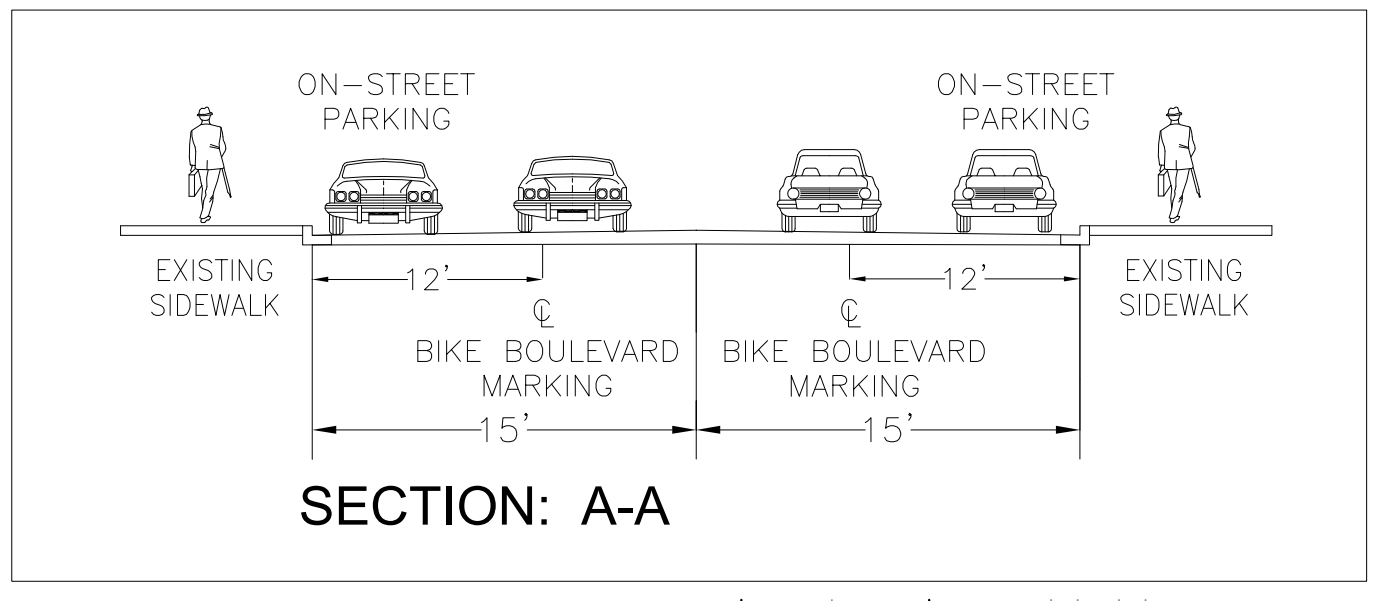
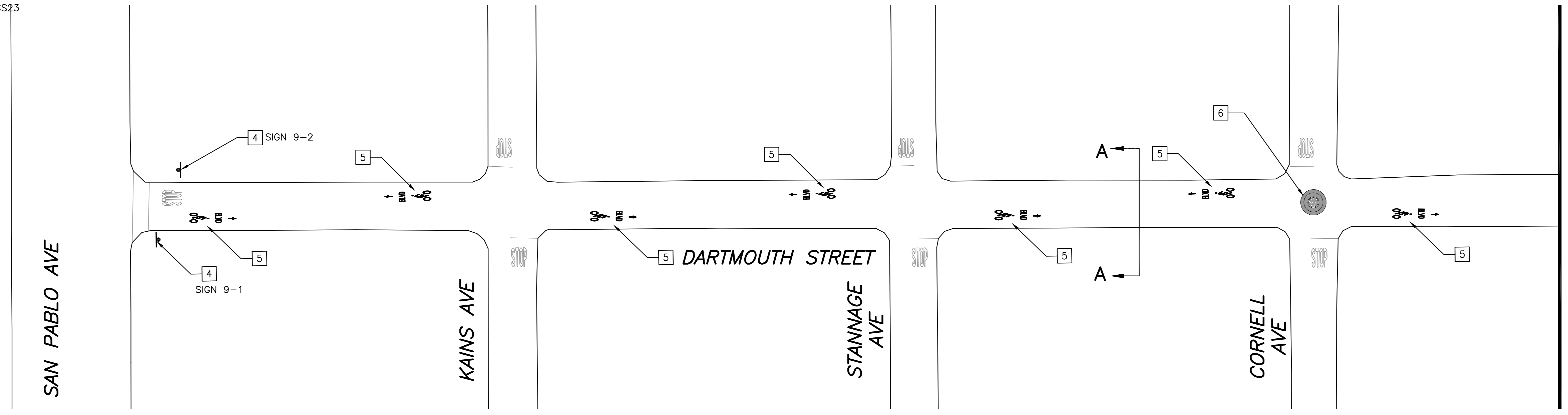
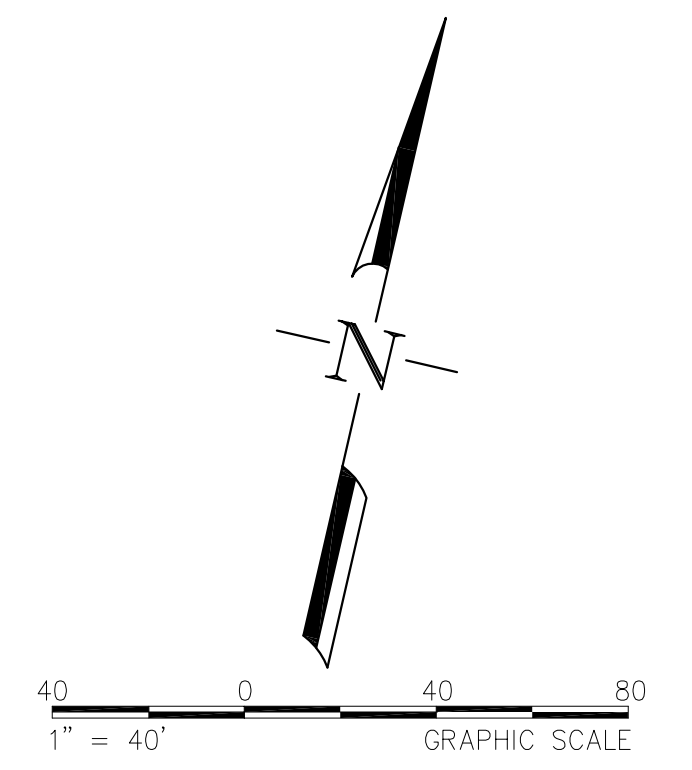

Nov 07, 2014 CADD FILE: N:\PROJECTS\WC13\WC13-3073-Albany_ATP_Signing-Striping-CAD\65_Submittal\3073-SS1_SS8-ATP_3-15.dwg

REVISIONS			
NO.	DESCRIPTION	DATE	BY

FEHR PEERS

100 Pringle Avenue Walnut Creek, CA 94596
Suite 600 (925) 930-7100

Walnut Creek, CA San Diego, CA
 Roseville, CA Oakland, CA
 San Jose, CA Salt Lake City, UT
 San Francisco, CA Reno, NV
 Orange County, CA Denver, CO
 Los Angeles County, CA Seattle, WA



Designed By: PS/RM
 Drawn By: PS/DD
 Checked By: RM
 Drawing No.: WC13-3073
 Date: 11/07/2014

ALBANY ACTIVE TRANSPORTATION PLAN
 ATP PROJECT #15 - DARTMOUTH AVENUE
 SIGNING & STRIPING PLAN

Fehr & Peers Associates, its employees, its officers or agents shall not be responsible for the accuracy or completeness of electronic copies of this plan sheet.

PROJECT NOTES (THIS SHEET ONLY):

- 1 INSTALL SHARROW PER DETAIL 'A' ON SHEET SS1.
- 2 INSTALL BIKE LANE STENCIL PER DETAIL 'B' ON SHEET SS1
- 3 INSTALL BICYCLE BOX PER DETAIL 'D' ON SHEET SS1
- 4 INSTALL GUIDE SIGN PER DETAIL 'E' ON SHEET SS1. SEE SHEET SS21 FOR SIGN TEXT.
- 5 INSTALL BIKE BOULEVARD STENCIL PER DETAIL 'C' ON SHEET SS1

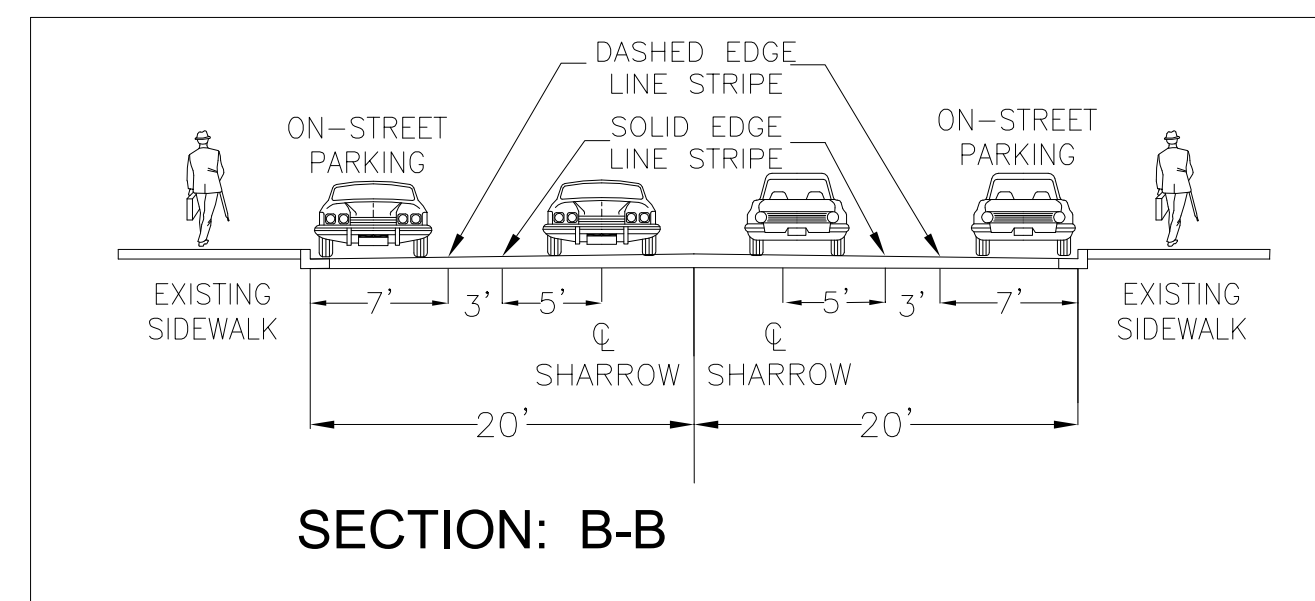
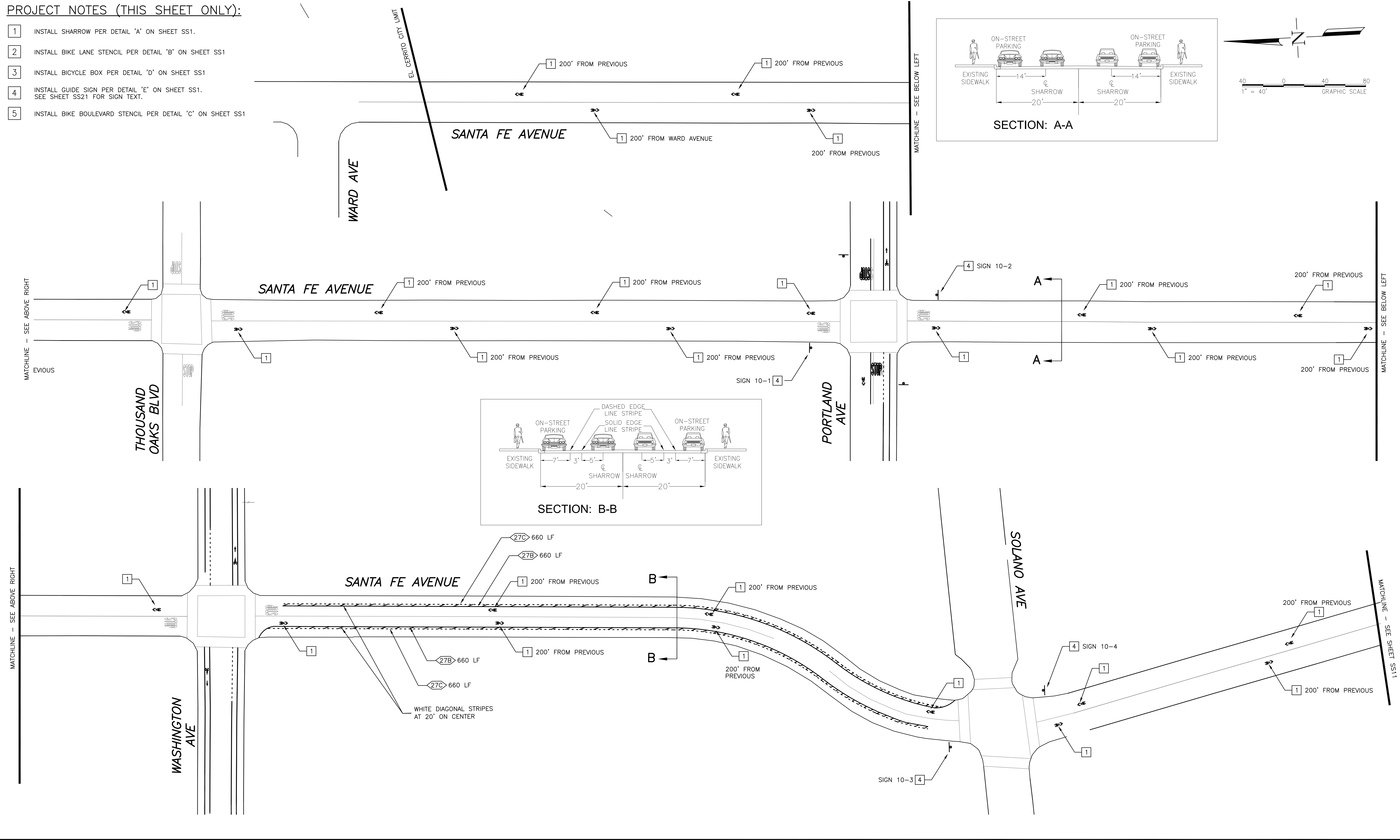
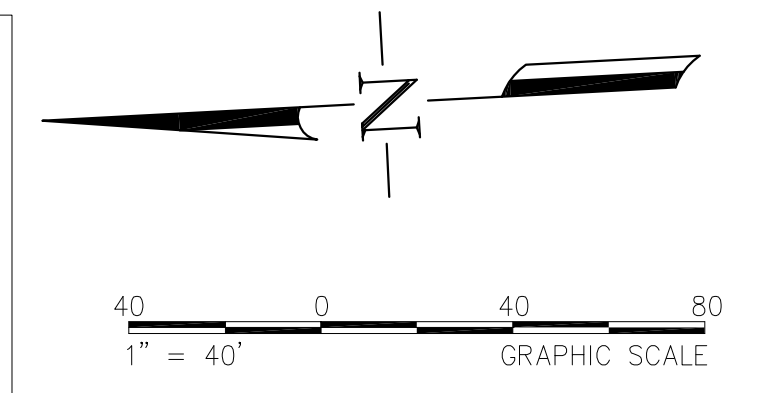
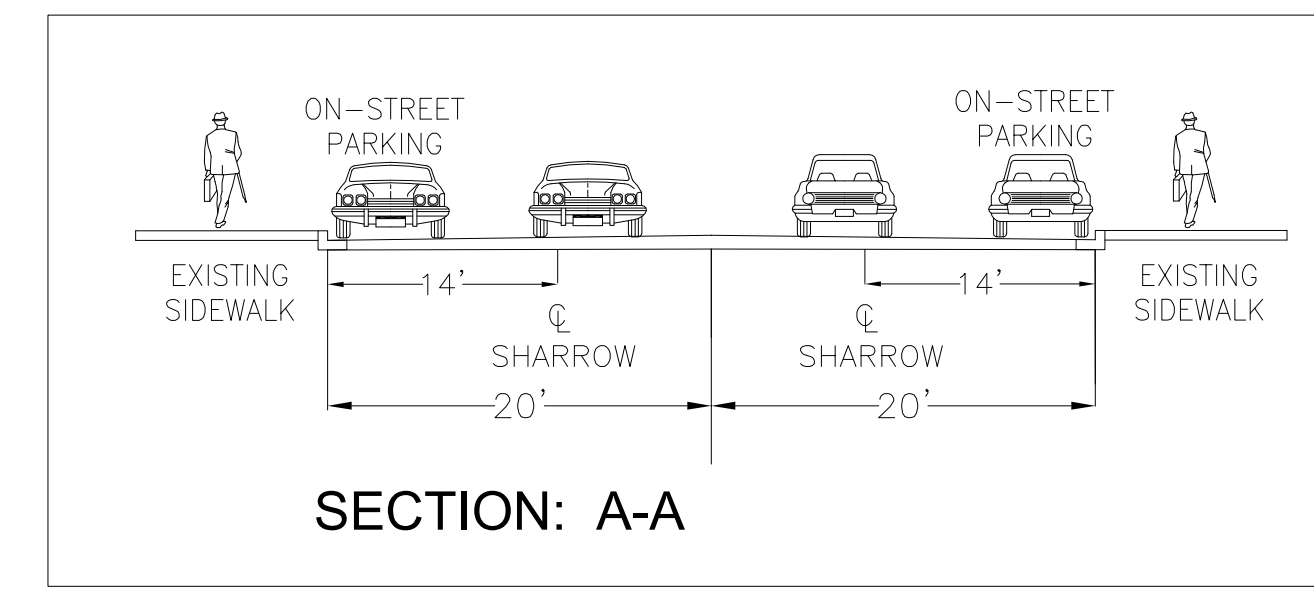

Nov 07, 2014 CADD FILE: N:\PROJECTS\WC13\WC13-3073\Albany_ATP_Signing-Striping-Storage\CAD\65_Submittal\3073-SS9-SSX-ATP_17-26.dwg

REVISIONS			
NO.	DESCRIPTION	DATE	BY

FEHR PEERS

100 Pringle Avenue Walnut Creek, CA 94596
Suite 600 (925) 930-7100

- Walnut Creek, CA
- San Diego, CA
- Roseville, CA
- Oakland, CA
- San Jose, CA
- Salt Lake City, UT
- San Francisco, CA
- Reno, NV
- Orange County, CA
- Denver, CO
- Los Angeles County, CA
- Seattle, WA



Designed By: PS/RM
 Drawn By: PS/DD
 Checked By: RM
 Drawing No.: WC13-3073
 Date: 11/07/2014

ALBANY ACTIVE TRANSPORTATION PLAN

ATP PROJECT #17 - SANTA FE AVENUE
 (THOUSAND OAKS BLVD to SOLANO AVE)

SIGNING & STRIPING PLAN

SHEET
 SS10
 OF
 23

Fehr & Peers Associates, its employees, its officers or agents shall not be responsible for the accuracy or completeness of electronic copies of this plan sheet.

PROJECT NOTES (THIS SHEET ONLY):

- 1 INSTALL SHARROW PER DETAIL 'A' ON SHEET SS1.
- 2 INSTALL BIKE LANE STENCIL PER DETAIL 'B' ON SHEET SS1
- 3 INSTALL BICYCLE BOX PER DETAIL 'D' ON SHEET SS1
- 4 INSTALL GUIDE SIGN PER DETAIL 'E' ON SHEET SS1. SEE SHEET SS21 FOR SIGN TEXT.
- 5 INSTALL BIKE BOULEVARD STENCIL PER DETAIL 'C' ON SHEET SS1
- 6 INSTALL MODIFIED DETAIL 21 PER DETAIL 'H' ON SHEET SS1
- 7 REMOVE EXISTING HATCHED STRIPING, AND INSTALL BIKE LEGEND WITH LEFT TURN ARROW AND STOP STENCIL
- 8 INSTALL STOP LEGEND
- 9 INSTALL MODIFIED DETAIL 21 PER DETAIL 'H' ON SHEET SS1
- 10 INSTALL NEW CASE A CURB RAMP.
- 11 INSTALL DETAIL 27B STRIPING WITH ONE-WAY CLEAR RETROREFLECTIVE MARKERS.
- 12 INSTALL ADVANCE YIELD LINE

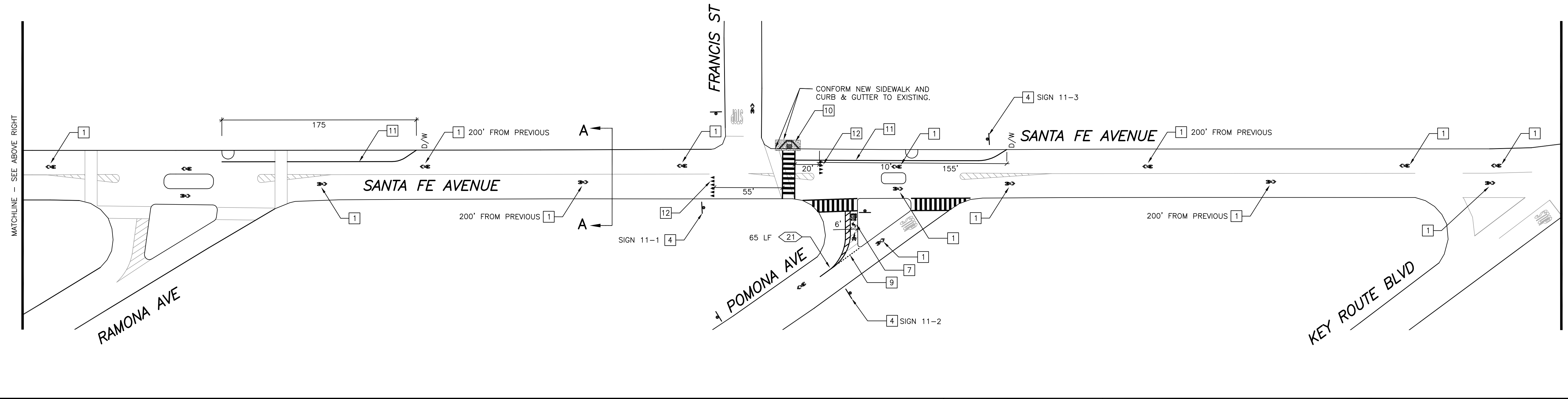
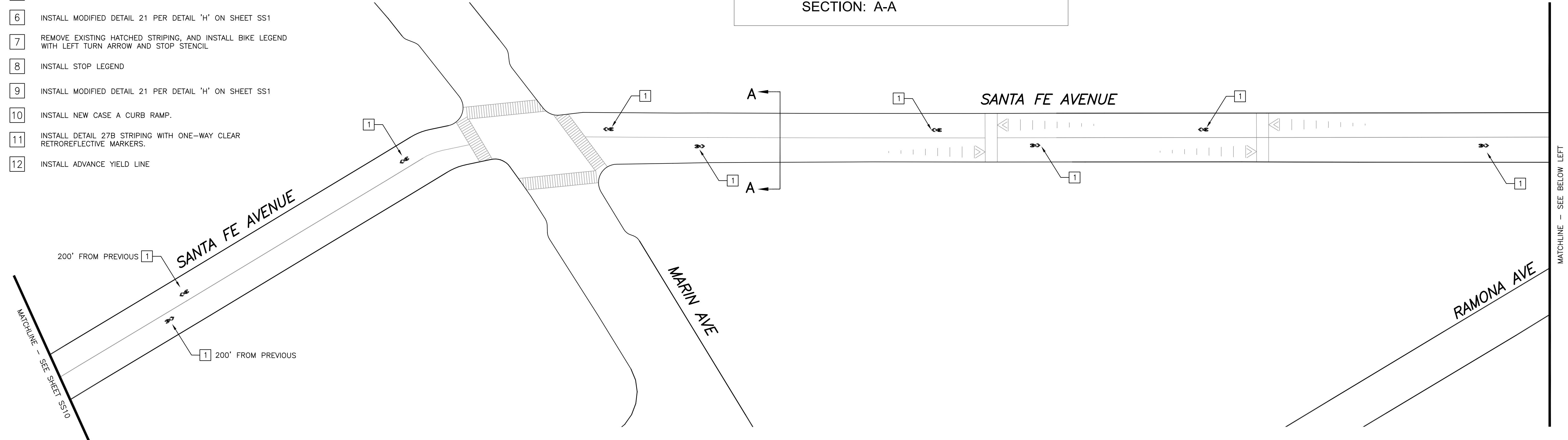
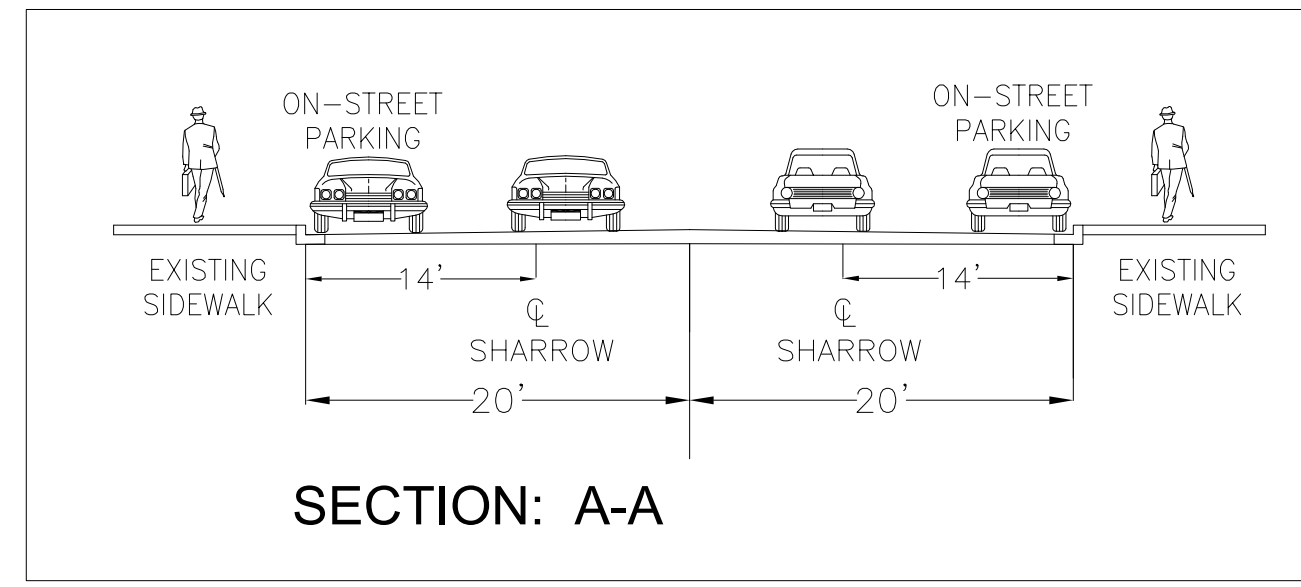
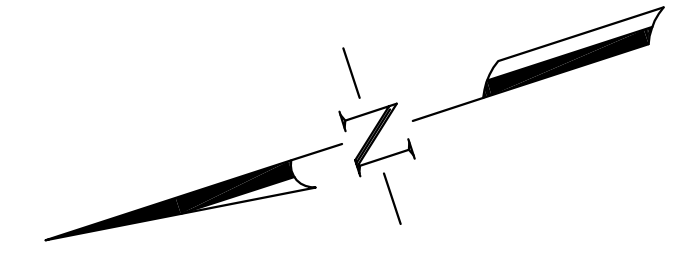

Nov 07, 2014 CADD FILE: N:\PROJECTS\WC13\WC13-3073-Albany_ATP_Signing-Striping-Signage\CAD\65_Submittal\3073-SS9-SSX-ATP_17-26_NEW.dwg

REVISIONS			
NO.	DESCRIPTION	DATE	BY

FEHR PEERS

100 Pringle Avenue Walnut Creek, CA 94596
(925) 930-7100

- Walnut Creek, CA
- San Diego, CA
- Roseville, CA
- Oakland, CA
- San Jose, CA
- Salt Lake City, UT
- San Francisco, CA
- Reno, NV
- Orange County, CA
- Denver, CO
- Los Angeles County, CA
- Seattle, WA



Designed By: PS/RM
 Drawn By: PS/DD
 Checked By: RM
 Drawing No.: WC13-3073
 Date: 11/07/2014

ALBANY ACTIVE TRANSPORTATION PLAN

ATP PROJECT #17 - SANTA FE AVENUE
 (MARIN AVE to POMONA AVE)
 SIGNING & STRIPING PLAN

SHEET
 SS11
 OF
 23

Fehr & Peers Associates, its employees, its officers or agents shall not be responsible for the accuracy or completeness of electronic copies of this plan sheet.

PROJECT NOTES (THIS SHEET ONLY):

- 1 INSTALL SHARROW PER DETAIL 'A' ON SHEET SS1.
- 2 INSTALL BIKE LANE STENCIL PER DETAIL 'B' ON SHEET SS1
- 3 INSTALL BICYCLE BOX PER DETAIL 'D' ON SHEET SS1
- 4 INSTALL GUIDE SIGN PER DETAIL 'E' ON SHEET SS1. SEE SHEET SS21 FOR SIGN TEXT.
- 5 INSTALL BIKE BOULEVARD STENCIL PER DETAIL 'C' ON SHEET SS1

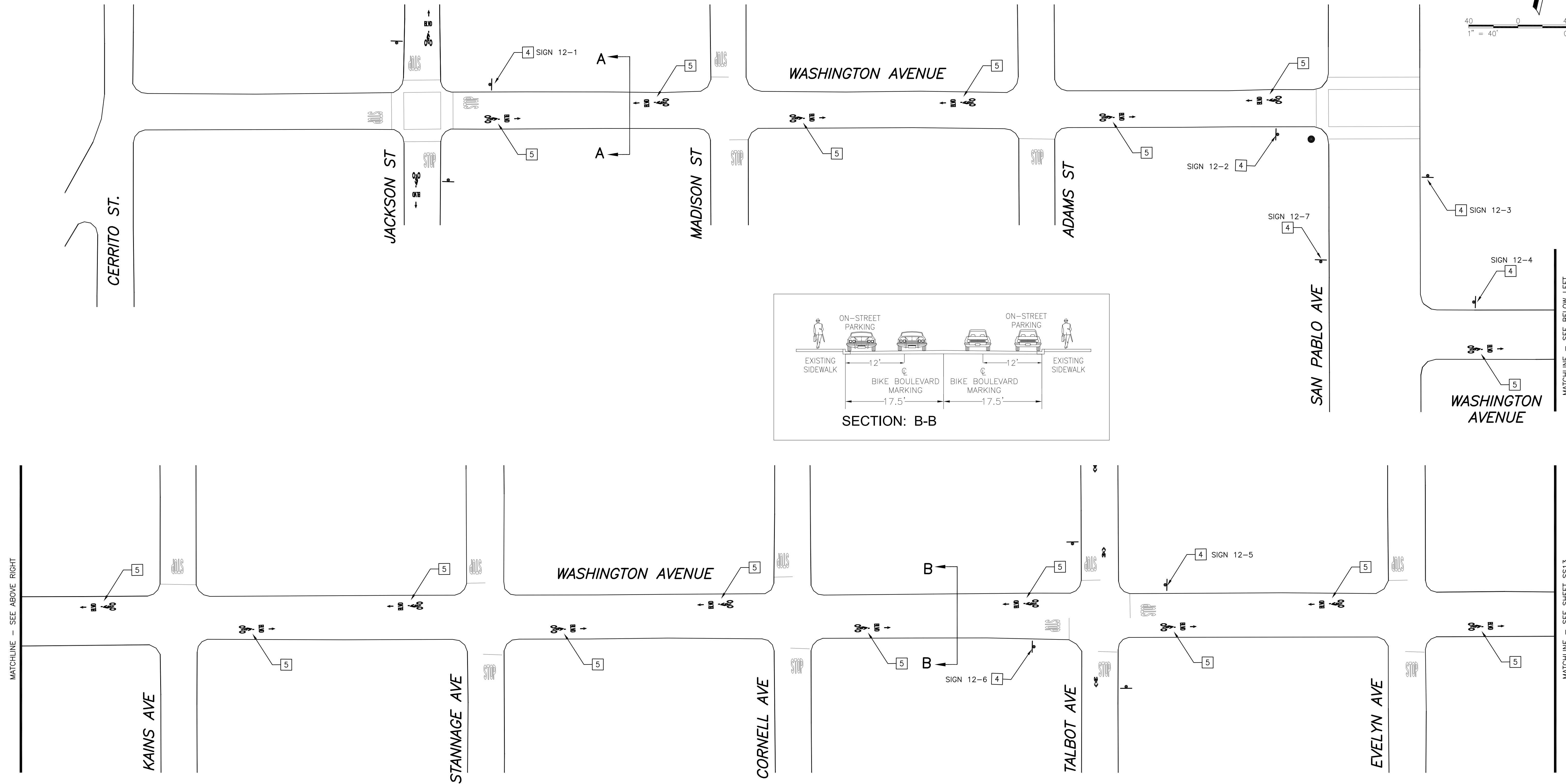
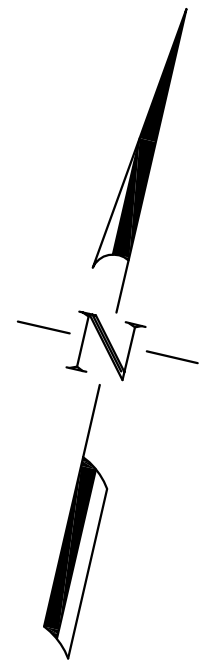
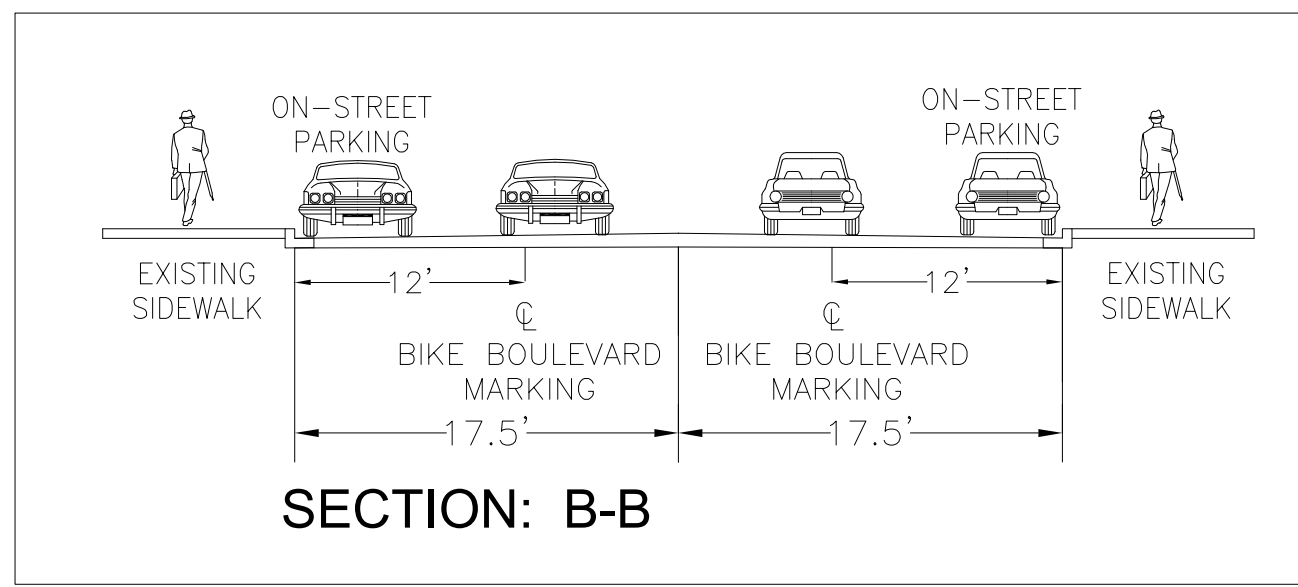
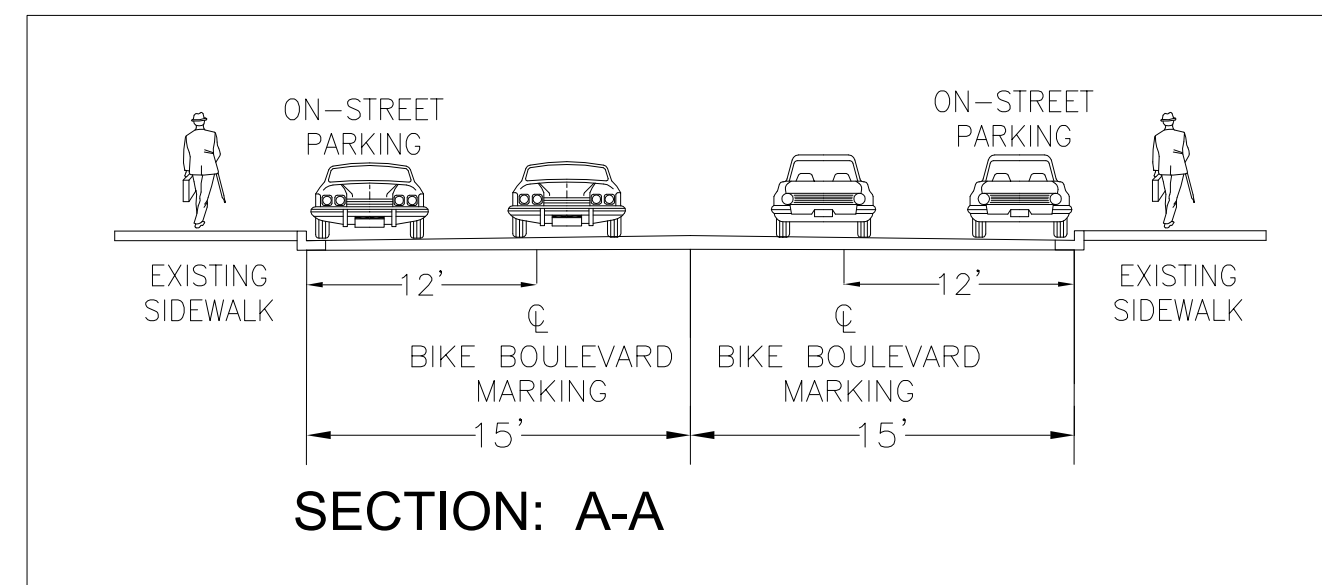

Nov 07, 2014 CADD FILE: N:\PROJECTS\WC13\WC13-3073\Albany_ATP_Striping-Signage\CAD\65_Submittal\3073-SS9-SSX-ATP_17-26.dwg

REVISIONS			
NO.	DESCRIPTION	DATE	BY

FEHR & PEERS

100 Pringle Avenue Walnut Creek, CA 94596 (925) 930-7100

- Walnut Creek, CA
- San Diego, CA
- Roseville, CA
- Oakland, CA
- San Jose, CA
- Salt Lake City, UT
- San Francisco, CA
- Reno, NV
- Orange County, CA
- Denver, CO
- Los Angeles County, CA
- Seattle, WA



Designed By: PS/RM
 Drawn By: PS/DD
 Checked By: RM
 Drawing No.: WC13-3073
 Date: 11/07/2014

ALBANY ACTIVE TRANSPORTATION PLAN

ATP PROJECT #18 - WASHINGTON AVENUE
 CERRITO AVE TO EVELYN AVE)
 SIGNING & STRIPING PLAN

SHEET
 SS12
 — OF —
 23

Fehr & Peers Associates, its employees, its officers or agents shall not be responsible for the accuracy or completeness of electronic copies of this plan sheet.