

FLOOR AREA RATIO

PROPOSED GARAGE	= 330 S.F.
PROPOSED FIRST FLOOR	= 1,235 S.F.
PROPOSED SECOND FLOOR	= 1,042 S.F.
GARAGE EXEMPTION	= -220 S.F.
TOTAL SQ. FT.	= 2,387 S.F.
ALLOWABLE F.A.R. .55 X 4,522 S.F. = 2,487 S.F.	

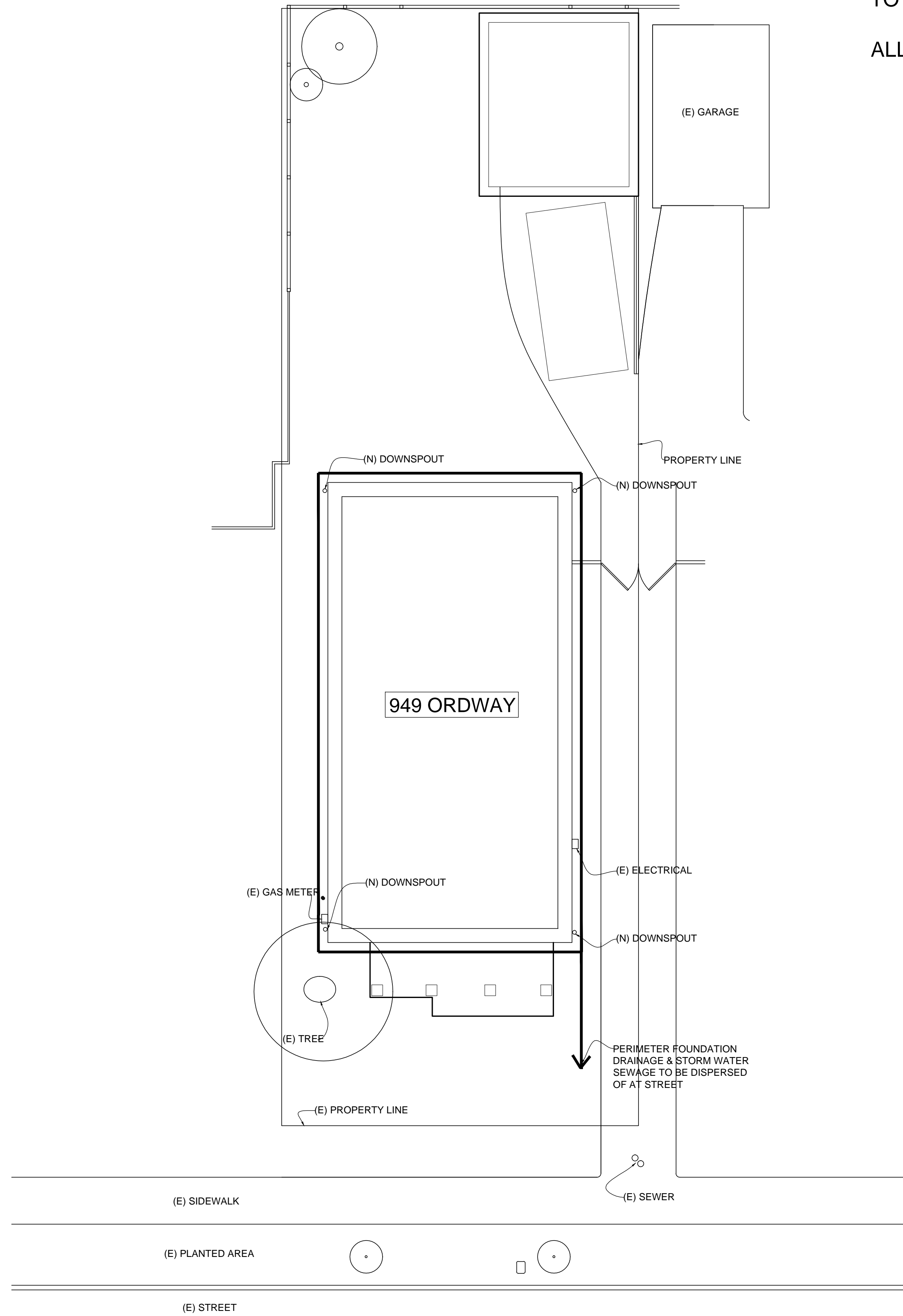

2 Existing Site/Drainage Plan
1/4" = 1'-0"

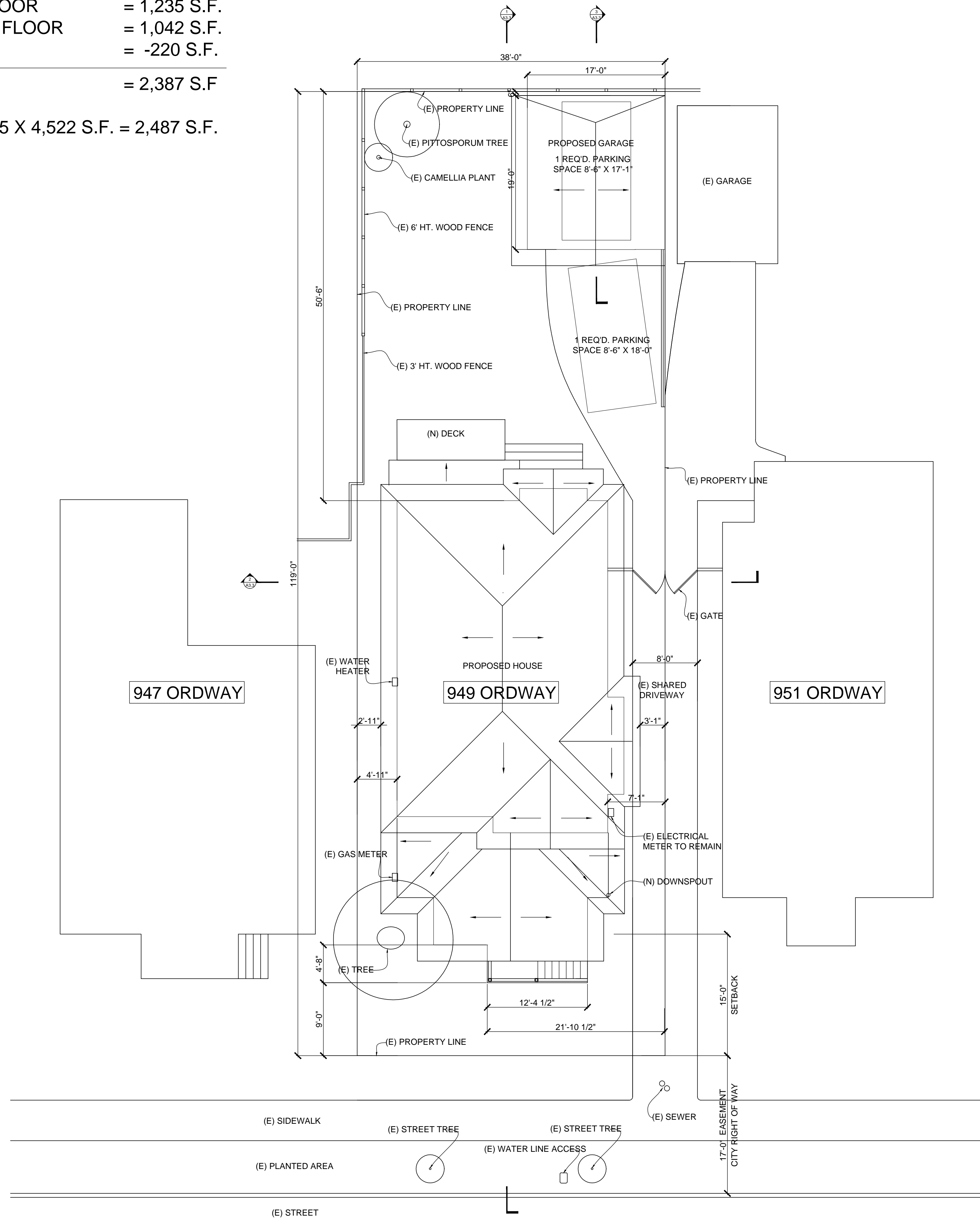

1 Proposed Site/Roof Plan
1/4" = 1'-0"

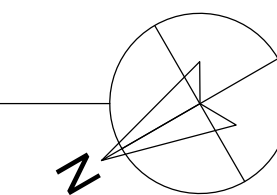

949 Ordway Street
Albany, CA 94707



T: 510-250-2511
F: 510-225-2524
E: ethan@draftingcafe.com
www.draftingcafe.com

Robert Shear

**NOT FOR
CONSTRUCTION**

REVISIONS NO.	DESCRIPTION	DATE

SITE, ROOF AND DRAINAGE PLAN

DATE

PROJECT 12102

SCALE 1/8" = 1'-0"

A1.1

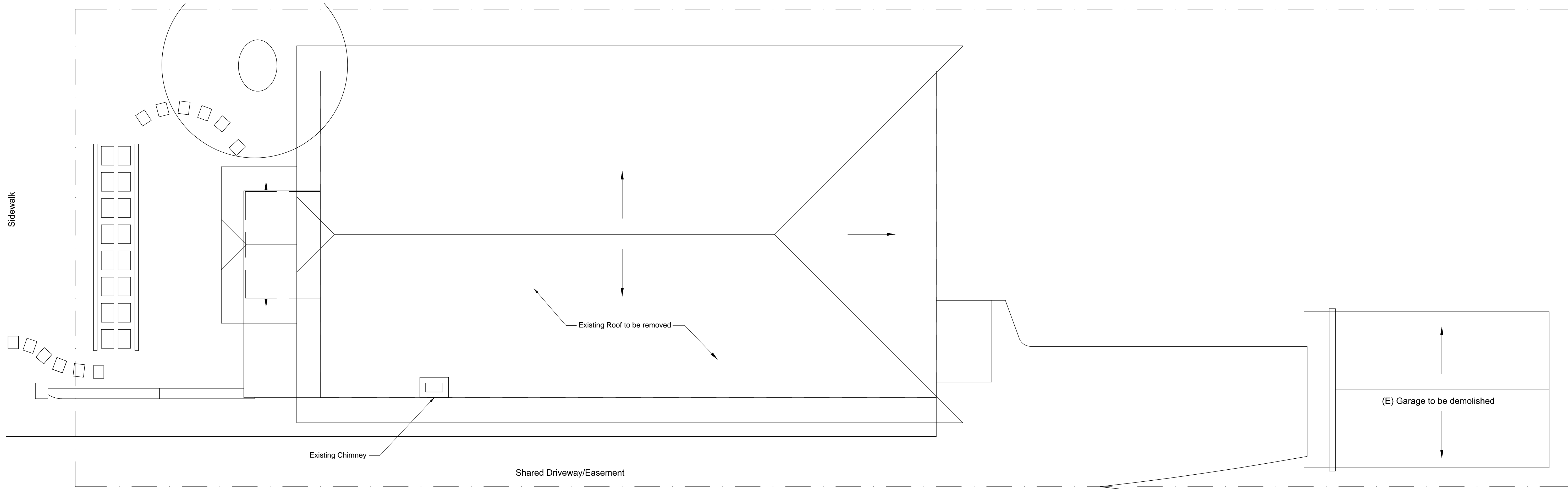

2 Existing Roof Plan
1/4" = 1'-0"

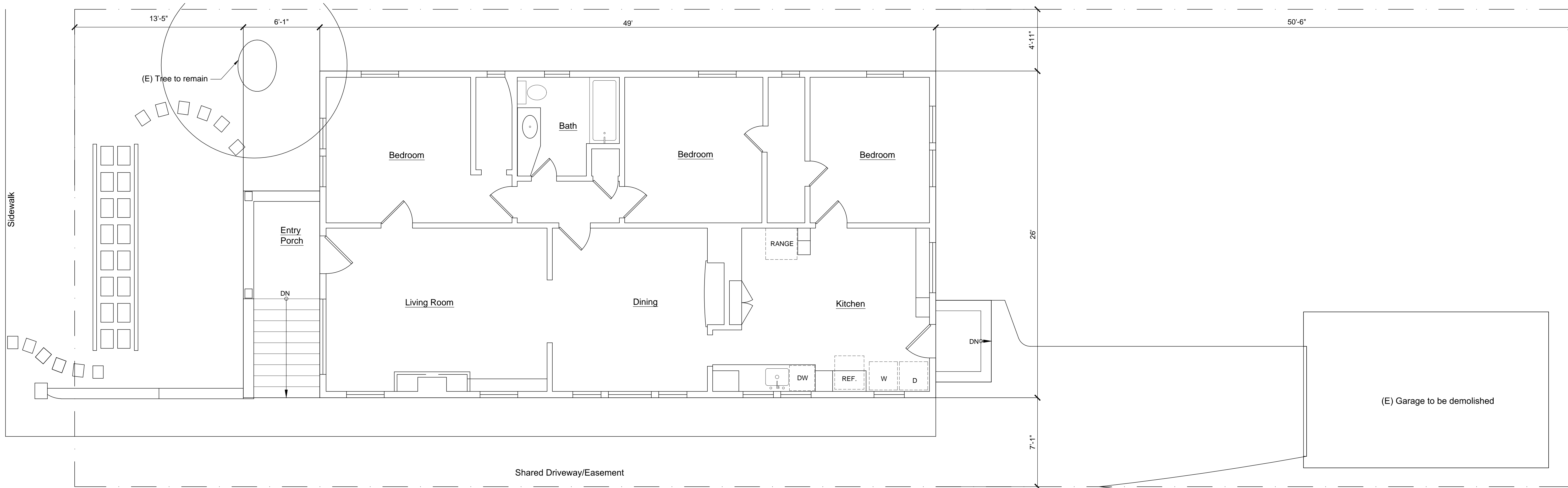

1 Existing First Floor Plan
1/4" = 1'-0"

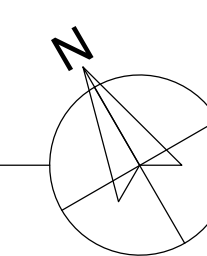

949 Ordway Street
Albany, CA 94707



T: 510-250-2511
F: 510-225-2524
E: ethan@draftingcafe.com
www.draftingcafe.com

Robert Shear

REVISIONS NO.	DESCRIPTION	DATE

EXISTING PLANS

DATE
PROJECT 12102
SCALE 1/4" = 1'-0"

A2.1

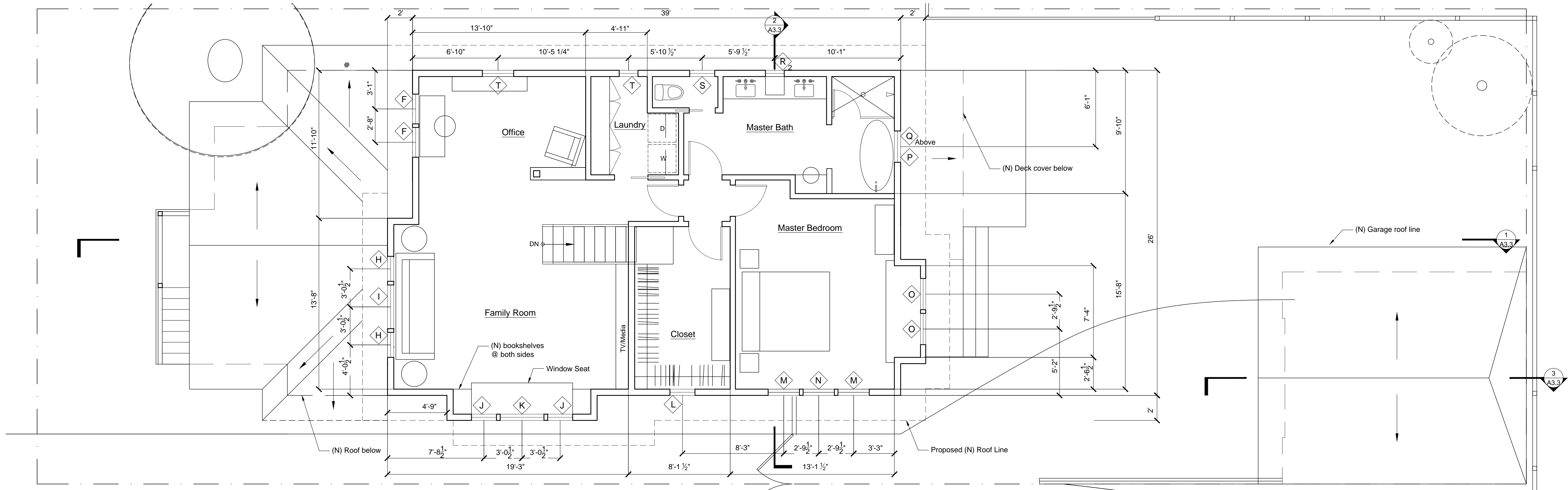

2 Proposed Second Floor Plan
1/4" = 1'-0"

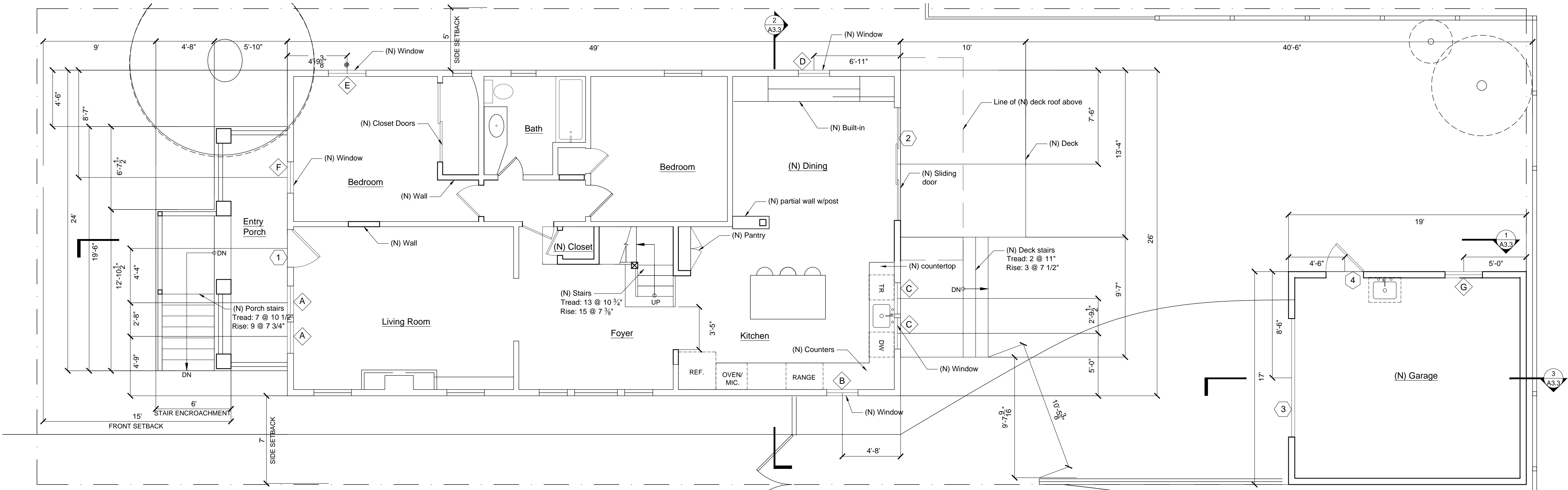

1 Proposed First Floor Plan
1/4" = 1'-0"

949 Ordway Street
Albany, CA 94707



T: 510-250-2511
F: 510-225-2524
E: ethan@draftingcafe.com
www.draftingcafe.com

Robert Shear

NOT FOR
CONSTRUCTION

REVISIONS NO.	DESCRIPTION	DATE

PROPOSED PLANS

DATE
PROJECT 12102
SCALE 1/4" = 1'-0"

A2.2

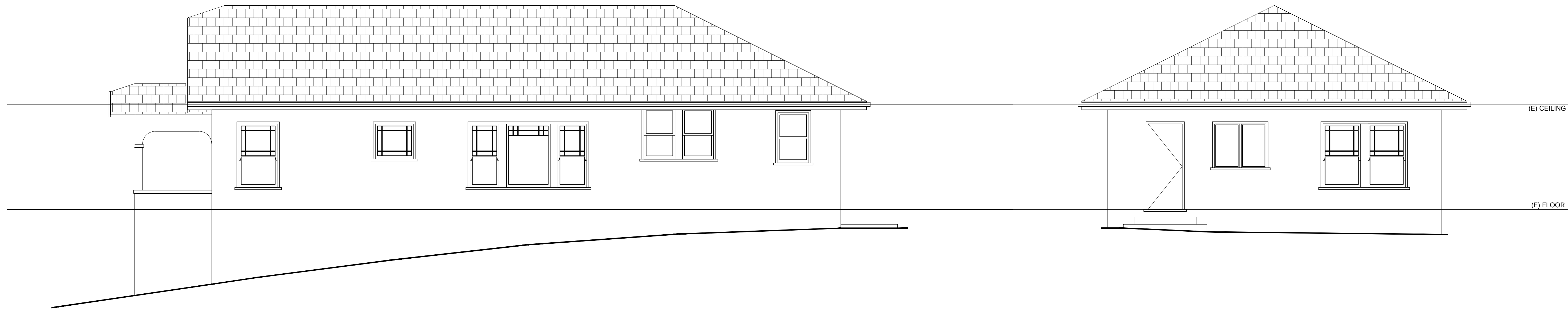

4 Proposed South Elevation
1/4" = 1'-0"

2 Proposed East Elevation
1/4" = 1'-0"

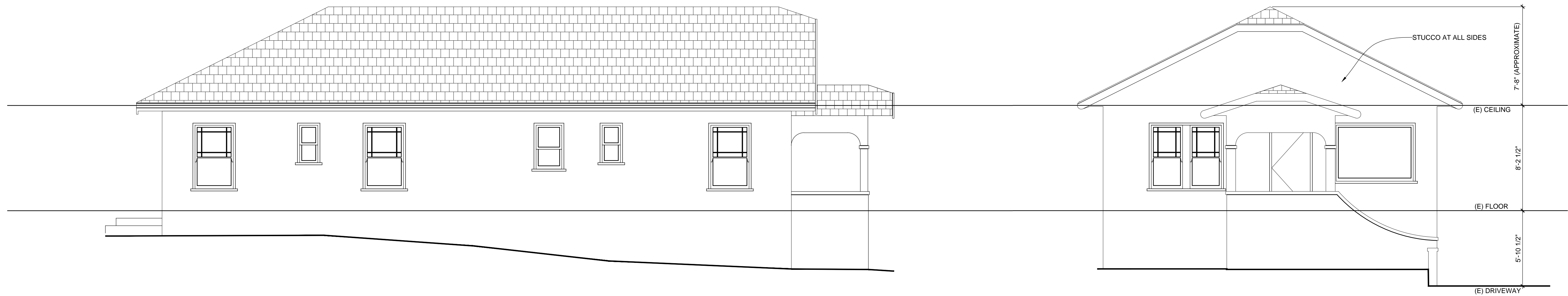

3 Proposed North Elevation
1/4" = 1'-0"

1 Proposed West Elevation
1/4" = 1'-0"

949 Ordway Street
Albany, CA 94707



T: 510-250-2511
F: 510-225-2524
E: ethan@draftingcafe.com
www.draftingcafe.com

Robert Shear

REVISIONS NO.	DESCRIPTION	DATE

EXISTING ELEVATIONS

DATE

PROJECT 12102

SCALE 1/4" = 1'-0"

A3.1



4 Proposed South Elevation
1/4" = 1'-0"

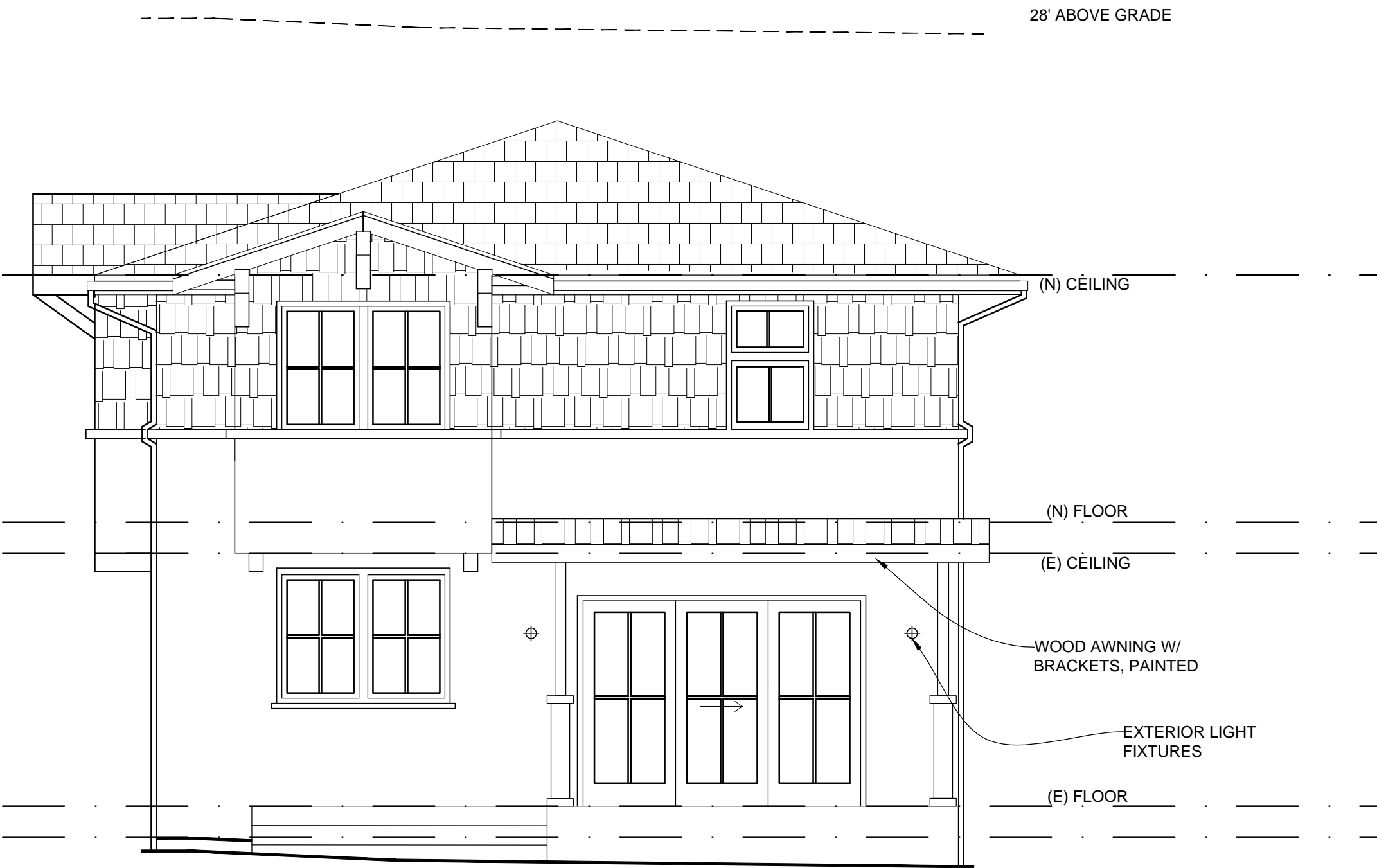

2 Proposed East Elevation
1/4" = 1'-0"



3 Proposed North Elevation
1/4" = 1'-0"

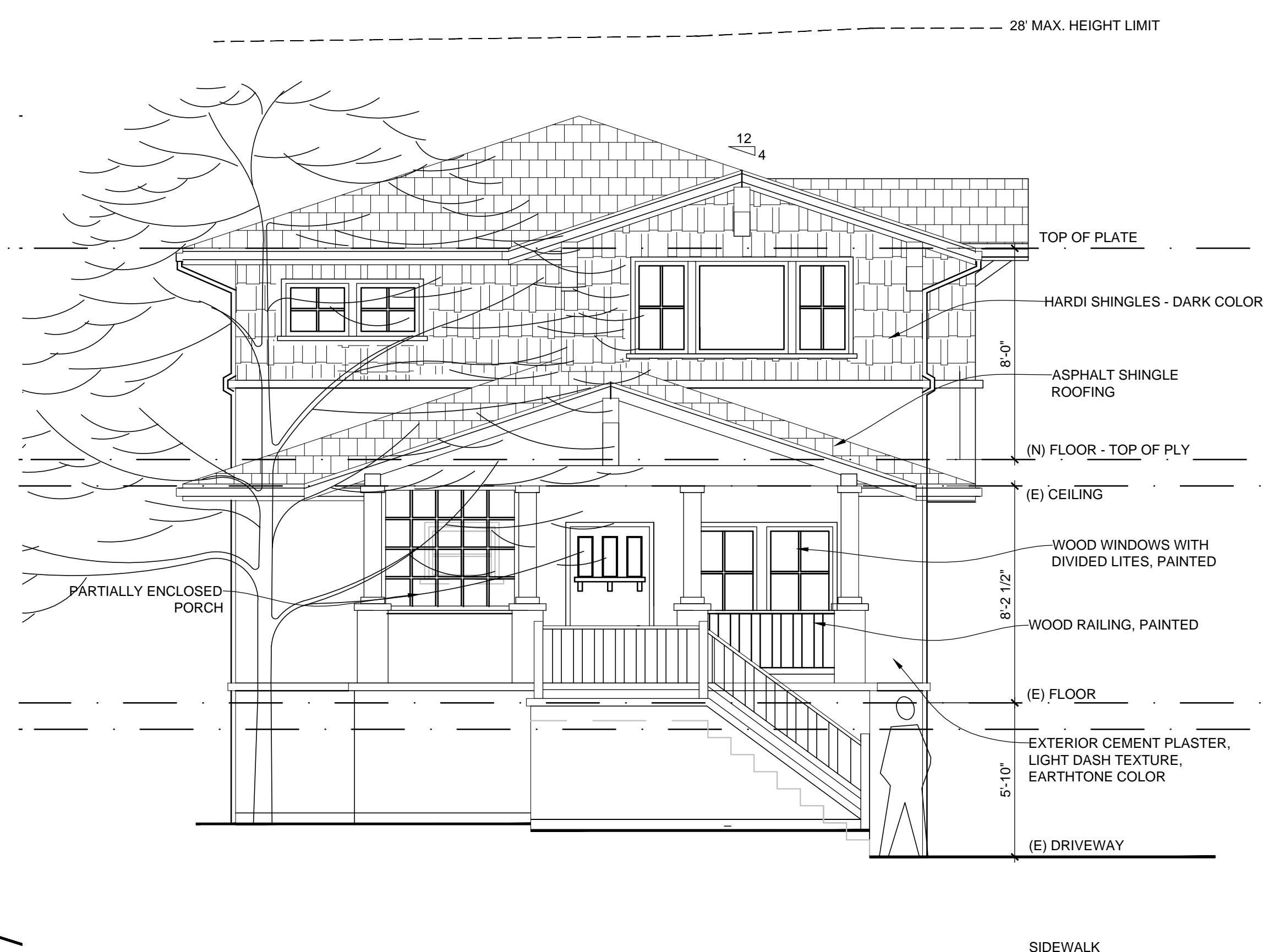

1 Proposed West Elevation
1/4" = 1'-0"

949 Ordway Street
Albany, CA 94707



T: 510-250-2511
F: 510-225-2524
E: ethan@draftingcafe.com
www.draftingcafe.com

Robert Shear

NOT FOR
CONSTRUCTION

REVISIONS
NO. DESCRIPTION
DATE

PROPOSED
ELEVATIONS

DATE

PROJECT 12102

SCALE 1/4" = 1'-0"

A3.2

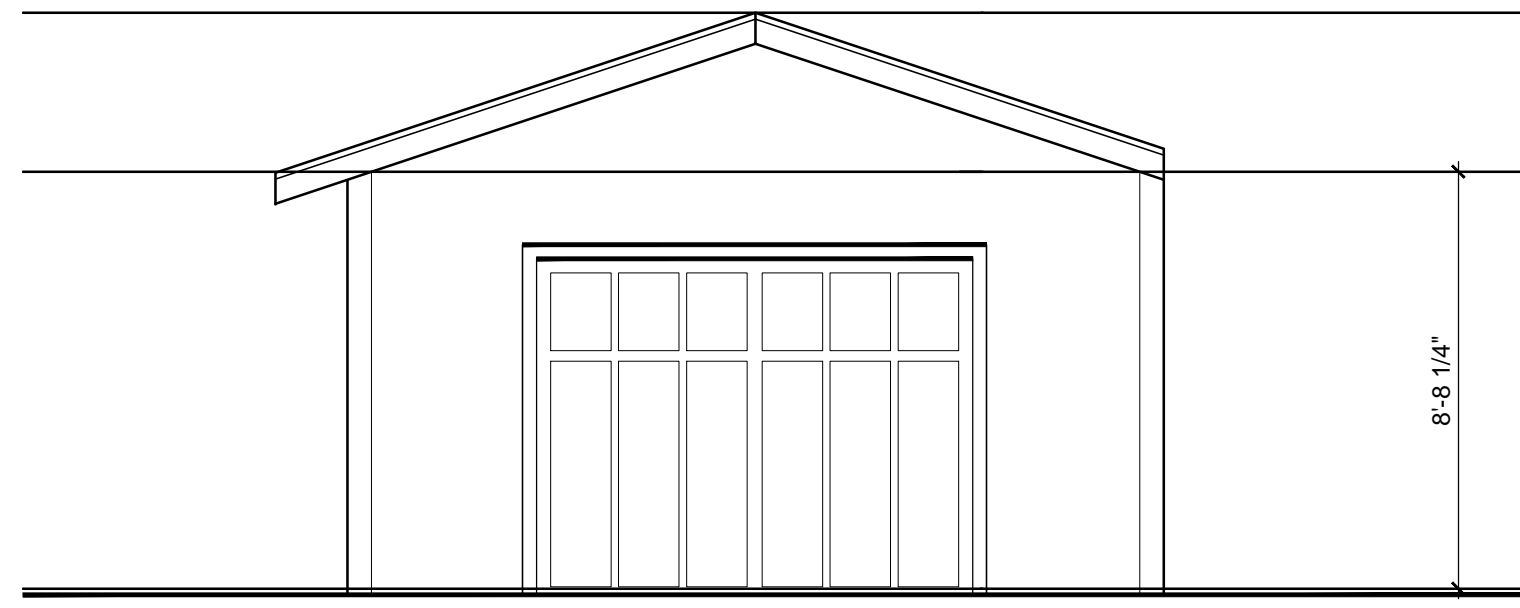

6 Proposed West Building Elevation
1/4" = 1'-0"

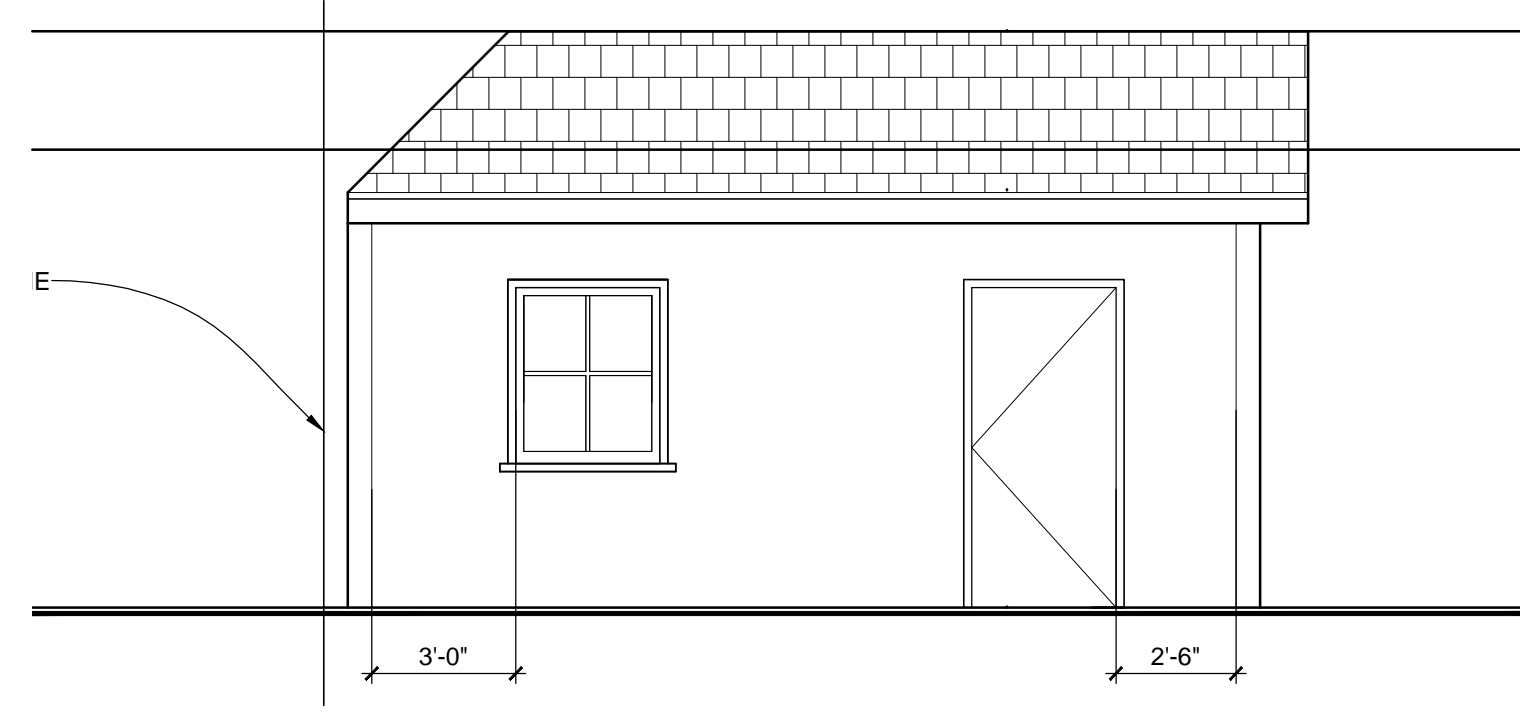

5 Proposed North Garage Elevation
1/4" = 1'-0"

Window and Door Schedule							
SYMBOL	QUANTITY	TYPE	SIZE	SPI MODEL	GLASS	LITES	NOTES
A	2	Casement	2'-6" x 3'-6"	C-WC-3042	Tempered	yes	
B	1	Casement	2'-6" x 4'-0"	C-WC-3048	Standard	yes	
C	2	Casement	2'-6" x 4'-0"	C-WC-3048	Standard	yes	
D	1	Awning	2'-6" x 4'-0"	C-WC-3048	Standard	yes	
E	1	Double Hung	3'-0" x 5'-0"	C-DHC-3660	Standard	no	
F	3	Fixed	3'-0" x 2'-0"	C-WA-3024	Standard	yes	
G	1						
H	2	Flanker	2'-0" x 3'-6"	C-WC-3042	Standard	yes	
I	1	Picture	3'-6" x 3'-6"	C-WCP-3042	Standard	yes	
J	2	Flanker	2'-0" x 3'-6"	C-WC-3054	Standard	yes	
K	1	Picture	3'-6" x 3'-6"	C-WCP-3054	Standard	yes	
L	1	Awning	2'-0" x 2'-6"	C-WA-2430	Standard	no	
M	2	Fixed	2'-6" x 2'-0"	C-WA-3024	Standard	yes	
N	1	Awning	2'-6" x 2'-0"	C-WA-3024	Standard	yes	
O	2	Casement	2'-6" x 4'-0"	C-WC-3048	Standard	yes	
P	1	Picture	2'-6" x 2'-3"	C-WCP-3036	Privacy	yes	
Q	1	Awning	2'-6" x 1'-6"	C-WA-3018	Standard	yes	
R	2	Awning	1'-6" x 1'-6"	C-WA-1818	Privacy	no	
S	1	Double Hung	2'-0" x 3'-0"	C-DHC-2436	Privacy	no	
T	1	Double Hung	1'-6" x 3'-6"	C-DHC-2436	Standard	no	
U	1	Casement	2'-6" x 3'-6"	C-WC-3-42	Standard	no	
1	1	Pre-hung front door	3'-0" x 6'-8"				
2	1	French slider	10'-0" x 6'-8"	C-PS-10680-3 (ROO)	Standard	yes	

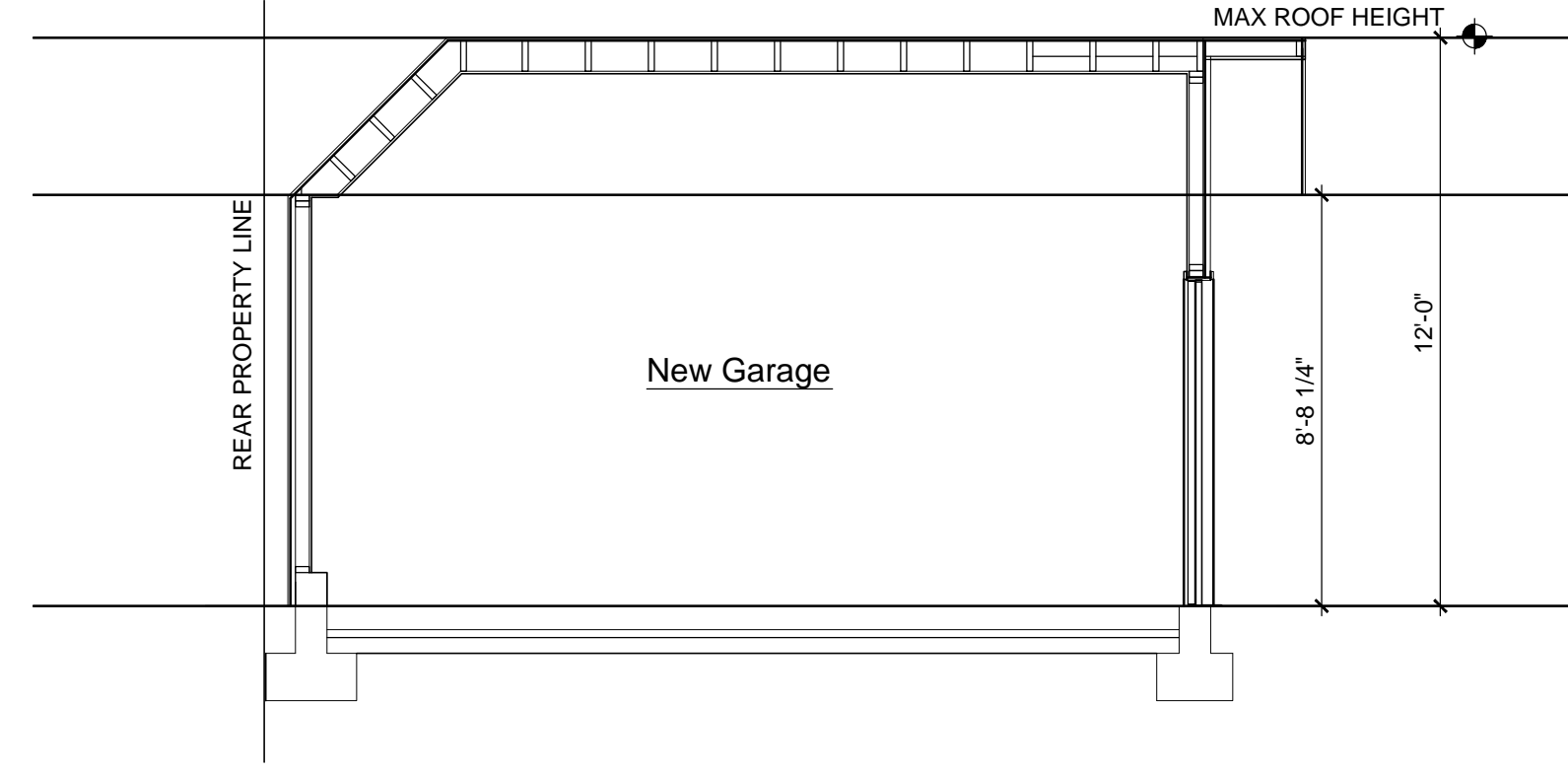

3 Proposed Garage Building Section
1/4" = 1'-0"

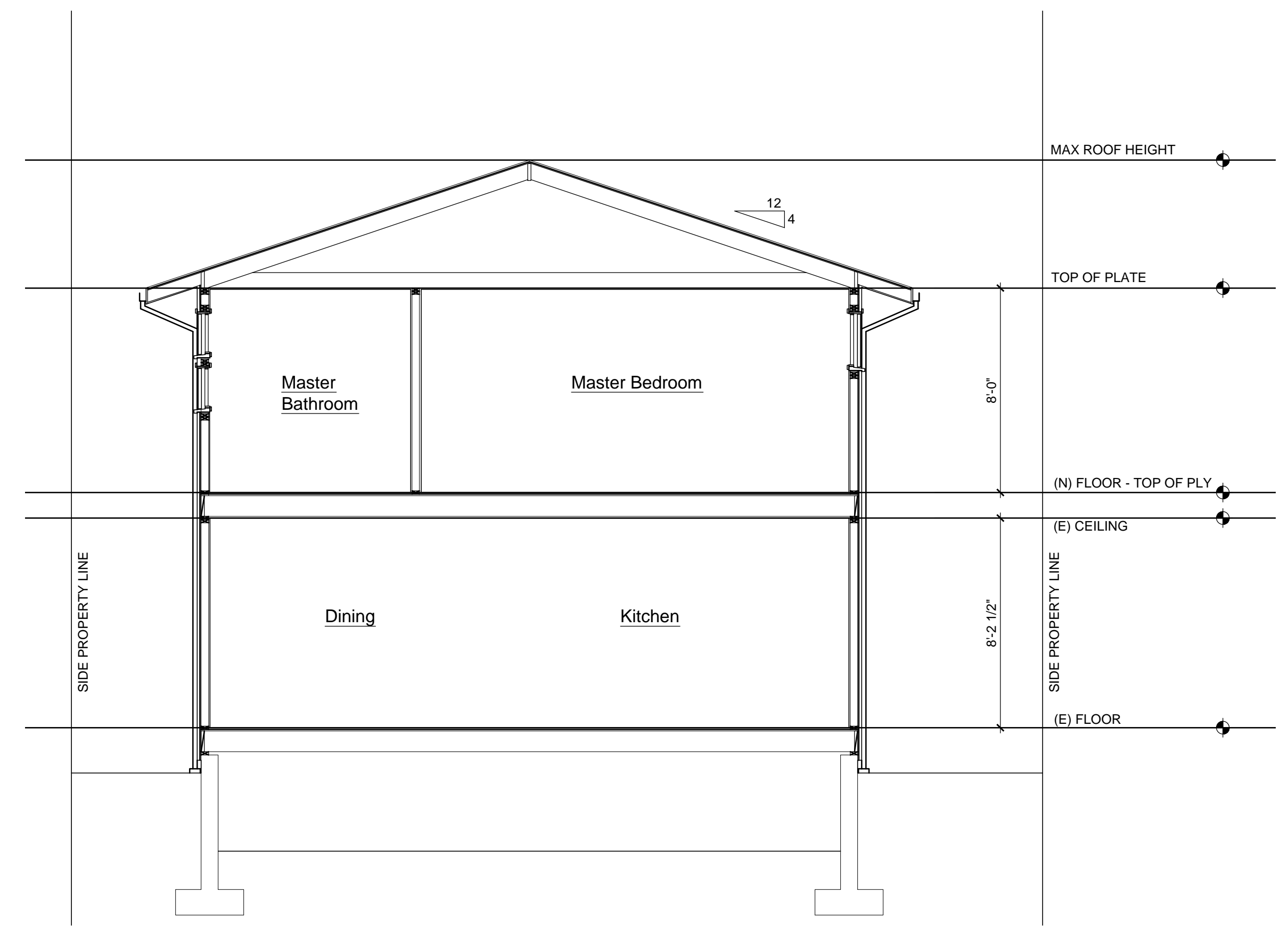

2 Proposed Building Section
1/4" = 1'-0"

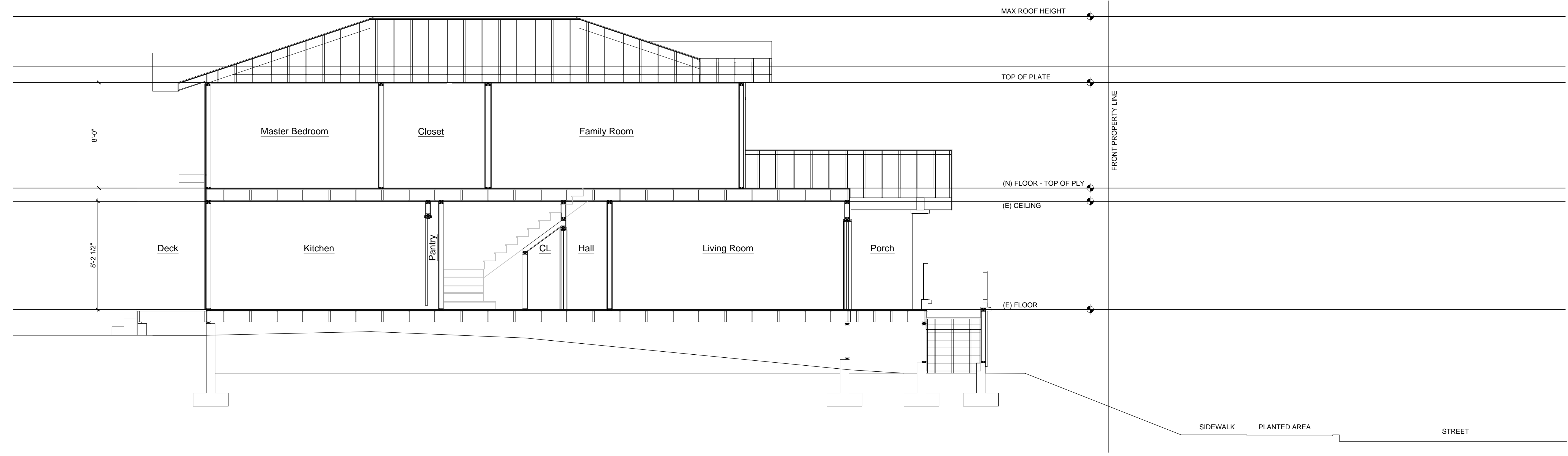

1 Proposed Building Section
1/4" = 1'-0"

949 Ordway Street
Albany, CA 94707



T: 510-250-2511
F: 510-225-2524
E: ethan@draftingcafe.com
www.draftingcafe.com

Robert Shear

NOT FOR CONSTRUCTION

REVISIONS NO.	DESCRIPTION	DATE

BUILDING SECTIONS
DATE
PROJECT 12102
SCALE 1/4" = 1'-0"

A3.3

Colonial 4 ⁹/₁₆" Jamb Vertical/Operable Section

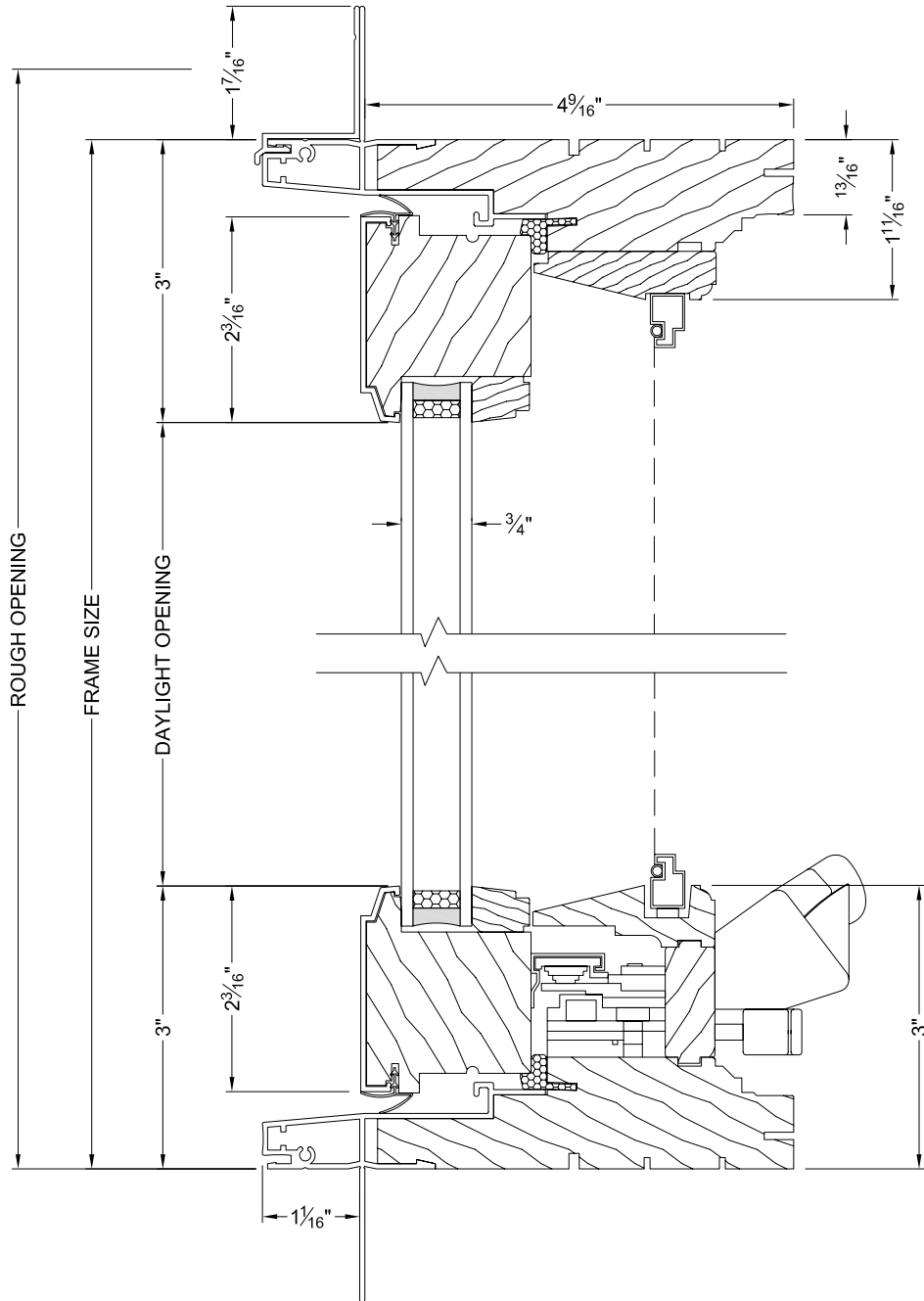

Colonial 4 ⁹/₁₆" Jamb

Horizontal/Operable Section

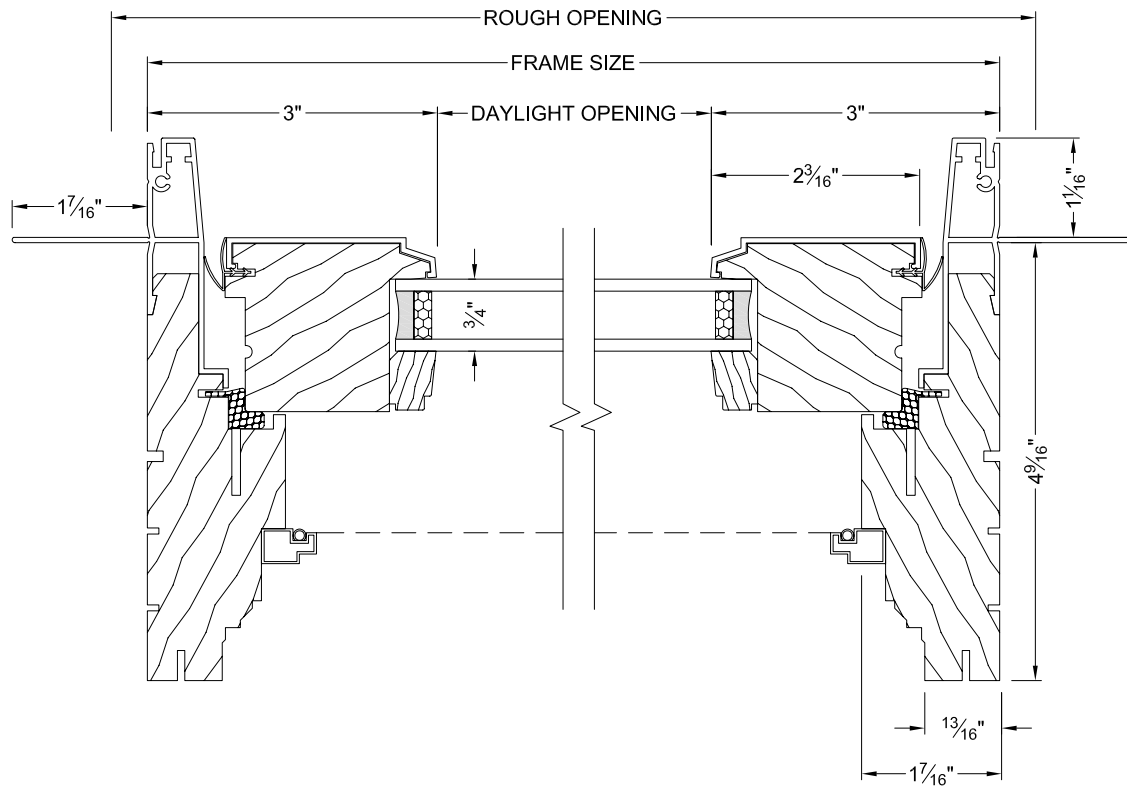

Standard 4 9/16" Jamb Vertical/Operable Section

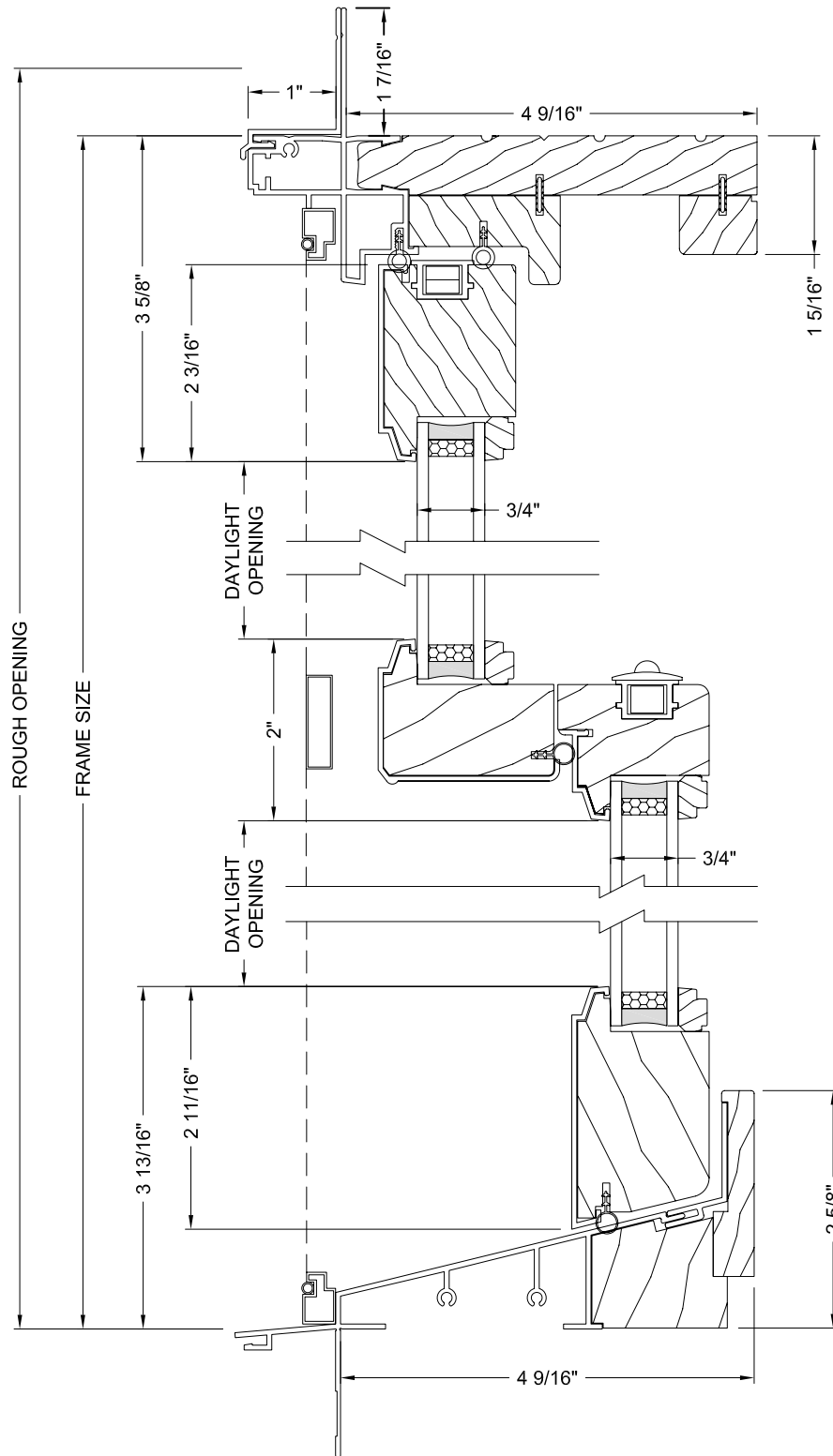

Standard 4 9/16" Jamb

Horizontal/Operable Section

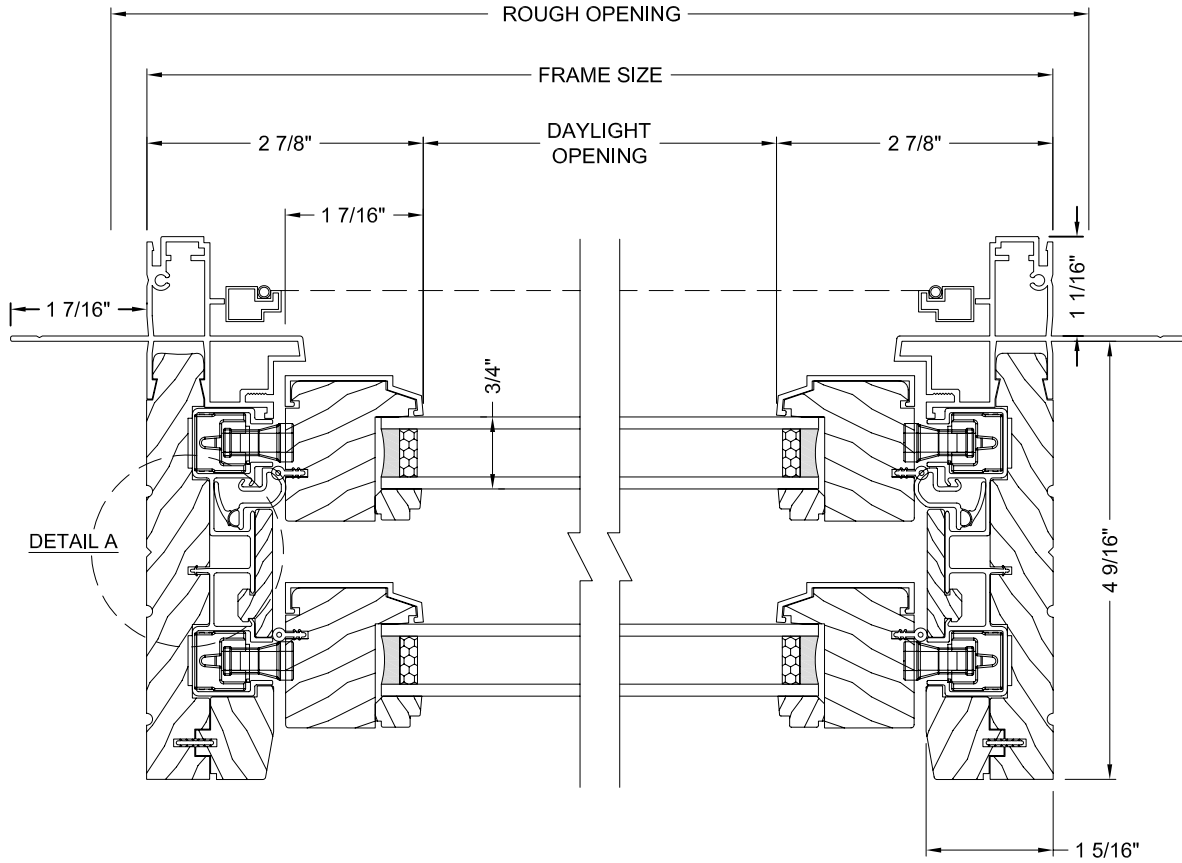

DETAIL A-JAMB JACK
(centered vertically on each jamb)

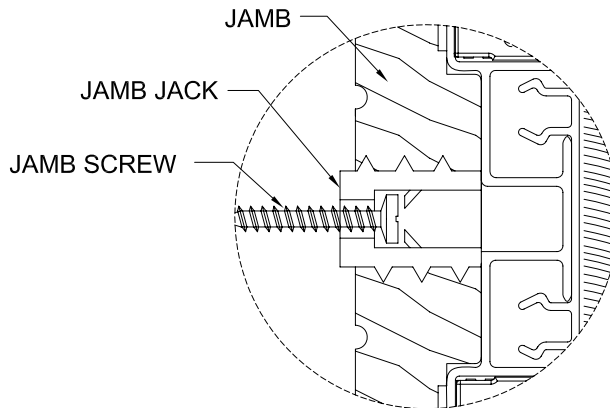

Scale; 2:1

