

**CITY OF ALBANY
PLANNING AND ZONING AGENDA
STAFF REPORT**

Agenda date: September 12, 2012
Prepared by: ALH

ITEM: 6A

SUBJECT: Planning Application 12-023: 812 Ramona Ave First and Second Story Addition

The applicant is seeking design review approval for a new 1st and 2nd story addition to the home at 812 Ramona. The existing home has 2 bedrooms and 1 bath and is 1,129 sq. ft. on a 5,000 sq. ft. lot. The applicant would like to add 659 sq. ft. to the first floor creating an expanded living room, dining room, and a new second bath. The second floor is proposed to be 976 sq. ft. and will include two new bedrooms, two bathrooms, and a bonus room. This results in a four bedroom, four bath home. The building height is proposed to be 21'8". One parking space will be provided in the garage and an uncovered parking space is proposed adjacent to the garage. The current home is a single story Arts & Crafts appearance and the proposed design is Neo-Mediterranean.

SITE: 812 Ramona Ave

OWNER/APPLICANT: David Guendelman and Carolina Balazs

ZONING: R-1 (Single-Family Residential)

STAFF RECOMMENDATION

The Planning and Zoning Commission review the proposed application and provide design feedback to the applicant and staff. Should the Commission choose to approve the proposed project, draft conditions and findings are included as an attachment to the staff report.

BACKGROUND/PROJECT DESCRIPTION

The subject property is a 5,000 square foot lot with an existing 1,129 sq. ft. single-story home. Currently, the existing living area is 863 sq. ft. with 76 sq. ft front porch and 190 sq. ft. detached garage. The applicant is proposing to add a first and second story addition which will increase the living area by 1,369 sq. ft. to 2,498 sq. ft. The home will increase from two bedrooms and one bathroom to four bedrooms and four bathrooms.

The proposed first story is 1522 sq. ft. with 245 sq. ft. single car garage. One additional bathroom facility is proposed on the first floor. The proposed second story is 976 sq. ft. total and will include 2 bedrooms, 2 bathrooms, and a 195 sq. ft. bonus room. The existing home is

proposed to remain stucco and clay tile roof. The proposed development accumulates 127 points from the Green Point Checklist.

The applicant is seeking design review approval of remodel of existing home and addition to existing first floor and new second floor of the home on 812 Ramona Avenue. The first floor is proposed to increase 659 sq. ft. in area with 245 sq. ft. garage. The proposed second floor addition is 976 sq. ft. This proposal results in 2498 sq. ft with 50% floor area ratio. The applicant would like to create on the first floor an additional bathroom, laundry, expanded living room, dining room, and garage. The second floor is proposed to have two bedrooms and two bathrooms. This results in a four bedroom, four bath home. One parking space will be provided in the garage and an uncovered parking space is proposed adjacent to the garage.

The applicant has shown Phase 1 and Phase 2 of the proposed development on the project plans. Phase 1 includes complete build out of the first floor and construction of a second floor bathroom, terrace and bonus room located directly above the garage. This new area is 278 sq. ft. The first Phase of construction results in a three (3) bedroom, two (2) bath home. Phase 2 includes the construction of a second floor master suite on the north side of the home and is 598 sq. ft.

ENVIRONMENTAL ANALYSIS

Staff has determined that the proposed project is categorically exempt from the requirements of the California Environmental Quality Act (CEQA) per Section 15303 “New Construction or Conversion of Small Structures” of the CEQA Guidelines, which exempts small additions.

SITE LOCATION



Figure 1. Site Location

DISCUSSION OF KEY ISSUES

Exterior Elevations

The existing single story home is 1,129 sq. ft. and maintains an Arts & Crafts appearance. The proposed two story home is 2,498 sq. ft., resulting in an increase of 1,369 sq. ft. The applicant is requesting the first story is to be 1522 sq. ft and the second story is proposed to be 976 sq. ft. The current home is an Arts & Crafts appearance and the proposed design is Neo-Mediterranean. The building height is proposed to be 21'8". The existing color scheme on the home is stucco and clay tile roof. Rooflines are varied and include front gable and side gable details. The proposed windows are round-arched, contemporary residential and skylight, and shown to be 2 inch recess from the building face.



Photo 1: Street view of 812 Ramona Avenue

Residential Design Guidelines

Below is a brief overview of consistency with the City's Residential Design Guidelines.

1. The front yard is the house's contribution to the street.
 - The front yard is proposed to remain the same.
2. Every house needs a usable front porch
 - A front porch is not proposed, though a landing at the front entrance is proposed.
3. Garages should have single-car doors and be attractive
 - A new panel garage door is proposed for the home.
4. Increasing the livability of the home
 - The home will increase in area from 1,129 sq. ft. (2 bedroom, 1 bath) to 2,498 sq. ft. (4 bedroom, 4 bath)
5. Dormers and bays are encouraged
 - A bay window is proposed for the south elevation.
6. Trim and details give a house warmth and character
 - Corbel details are proposed for all four elevations.
7. Building Materials
 - The home is proposed to be stucco with a clay tile roof.

8. Green Building
 - The applicant has provided the supplemental application form detailing the “green” efforts to be made as part of the project construction. This includes reusable building materials, resource-efficient landscapes and gardens, treated wood that doesn’t contain chromium/arsenic, compact fluorescent light bulbs, and Energy Star kitchen appliances. The Checklist provided by the applicant indicates a total score of 127 points.
9. Second-Units and Multi-family housing
 - N/A
10. Landscaping is an important aesthetic element of home design
 - The landscaping is proposed to remain the same.

Parking

Two off-street parking spaces are proposed. The narrowest width of the existing driveway is 12’ and is proposed to decrease to 8’6”. One off-street space will be provided in the garage and the other space will be provided in the driveway, adjacent to the garage, outside of the front setback.

Attachments:

1. Analysis of Zoning Requirements
2. Draft Findings for Approval
3. Draft Conditions of Approval
4. Project Plans & Application
5. Window Details
6. Photos of the Story Poles
7. Applicant Letter

20.24.050 Floor-Area-Ratio.

	Existing (approx.)	Proposed	Requirement
Lot Size	5,000	No change	--
Floor Area			
Garage/Storage	190	245	
Main Level	863	1522	--
Second-floor	N/A	976	
Total			--
Total Counted*	863 (863/5000)	2463	--
Floor Area Ratio*	17%	50%	55%

* 280 sq. ft. exempted from "total counted" as permitted by MC 20.24.050 for garage and stairs (220 sq. ft. for parking and 60 sq. ft. for stairs)

20.24.060 Setback Areas, Encroachments.

Not applicable.

20.24.100 Distances between Structures.

Not applicable.

20.24.110 Fences, Landscaping, Screening.

Not applicable.

20.24.130 Accessory Buildings.

See Discussion of Key Issues.

20.28 Off-Street Parking Requirement.

See Discussion of Key Issues.

20.40 Housing Provisions

Not applicable.

20.44 Non-conforming Uses, Structures and Lot

Not applicable.

20.48 Removal of Trees

Not applicable.

20.52 Flood Damage Prevention Regulations

Not applicable.

20.100.030 Use Permits.

Not applicable.

20.100.040 Variances.

Not applicable.

20.100.010 Common Permit Procedures.

Public notice of this application was mailed on June 15, 2012, in the form of mailed notice, to property owners and occupants within a 100-foot radius, and posted in one location.

20.100.050 Design Review.

See Summary of Key Issues.

ATTACHMENT 2 - FINDINGS

Findings for Design Review approval (Per section 20.100.050.E of the AMC)

<i>Required Finding</i>	<i>Explanation</i>
<p>1. <i>The project conforms to the General Plan, any applicable specific plan, applicable design guidelines adopted by the City of Albany, and all applicable provisions of this Chapter.</i></p>	<p>The General Plan designates this area for residential development. Additionally, the project meets City zoning standards for location, intensity and type of development.</p>
<p>2. <i>Approval of project design is consistent with the purpose and intent of this section, which states “designs of projects...will result in improvements that are visually and functionally appropriate to their site conditions and harmonious with their surroundings, including natural landforms and vegetation. Additional purposes of design review include (but are not limited to): that retention and maintenance of existing buildings and landscape features are considered; and that site access and vehicular parking are sufficient.”</i></p>	<p>The proposal is in scale and harmony with existing development in the vicinity of the site. The project will not require grading or excavation. The project will not create a visual detriment at the site or the neighborhood.</p> <p>The proposed addition is attractive in appearance, and is in scale with the surrounding neighbors. The design is complementary with the existing home.</p>
<p>3. <i>Approval of the project is in the interest of public health, safety and general welfare.</i></p>	<p>The proposed project will not be detrimental to the health, safety, convenience and welfare of those in the area and would not adversely impact property, improvements or potential future development in the area.</p>
<p>4. <i>The project is in substantial compliance with applicable general and specific Standards for Review stated in Subsection 20.100.050.D.</i></p>	<p>The project as designed is in substantial compliance with the standards as stated, including harmonious materials, and well proportioned massing .</p>

ATTACHMENT 3
COMMUNITY DEVELOPMENT DEPARTMENT CONDITIONS OF APPROVAL

GENERAL PROJECT CONDITIONS

- GEN-1 **Project Approval.** This Design Review approval is for 812 Ramona Ave, as substantially shown and described on the project plans, except as may be modified by conditions herein. Plans prepared by Santiago Balazs, date received July 18, 2012, as presented to the Planning and Zoning Commission on July 24, 2012. For any condition herein that requires preparation of a Final Plan where the project developer has submitted a conceptual plan, the project developer shall submit final plan(s) in substantial conformance with the conceptual plan, but incorporate the modifications required by the conditions herein for approval by the City.
- GEN-2 **Project Approval Expiration.** This Design Review approval will expire on September 27, 2013 (one year from the date on which this approval becomes effective) or at an alternate time specified as a condition of approval, unless a building permit has been issued and construction diligently pursued. The approval may be renewed by the Community Development Director for a period up to an additional two (2) years, provided that, at least ten (10) days before expiration of one (1) year from the date when the approval becomes effective, an application for renewal of the approval is filed with the Community Development Department. The Community Development Director may grant a renewal of an approval where there is no change in the original application, or there is no request to change any condition of approval.
- GEN-3 **FEES.** The applicant shall pay any and all City and other related fees applicable to the property, as may be modified by conditions herein. Fees shall be based on the current fee structure in effect at the time the relevant permits are secured, and shall be paid before issuance of said permit or before any City Council final action approval. Notice shall be taken specifically of Plan Check, Engineering, Fire and Inspection Fees. The project developer shall also reimburse the City for direct costs of planning; building and engineering plan check and inspection, as mutually agreed between the City and developer.
- GEN-4 **Appeals.** The Albany Municipal Code provides that any action of the Planning staff may be appealed to the Planning and Zoning Commission, and any action of the Planning and Zoning Commission may be appealed to the City Council as per the procedures described in Section 20.100.080. The City Clerk will then schedule the matter for the next available City Council meeting.
- GEN-5 **Requirement for Building Permit.** Approval granted by the Planning and Zoning Commission does not constitute a building permit or authorization to begin any construction or demolish an existing structure. An appropriate permit issued by the Community Development Department must be obtained before

constructing, enlarging, moving, converting, or demolishing any building or structure within the City.

- GEN-6 **Fire Department Approval.** As part of a building permit application, the applicant shall submit written documentation that all requirements of the Albany Fire Department have, or will be, met to the satisfaction of the AFD.
- GEN-7 **Engineering Approval.** As part of a building permit application, the applicant shall submit written documentation that all requirements of the Public Works Department have, or will be, met to the satisfaction of the City Engineer.
- GEN-8 **Construction Hours.** Construction activity shall be restricted to the hours of 8:00 a.m. to 6:00 p.m. Mondays through Saturdays, and 10:00 a.m. to 6:00 p.m., Sundays and legal holidays, unless otherwise approved in writing by the City Engineer for general construction activity. Failure to comply with construction hours may result in stop work orders or other administrative actions.
- GEN-9 **Archeological Remains.** In the event subsurface archeological remains are discovered during any construction or preconstruction activities on the site, all land alteration work within 100 feet of the find shall be halted, the Community Development Department notified, and a professional archeologist, certified by the Society of California Archeology and/or the Society of Professional Archeology, shall be notified. Site work in this area shall not occur until the archeologist has had an opportunity to evaluate the significance of the find and to outline appropriate mitigation measures, if deemed necessary. If prehistoric archeological deposits are discovered during development of the site, local Native American organizations shall be consulted and involved in making resource management decisions.
- GEN-10 **Modifications to Approved Plans.** The project shall be constructed as approved. Planning staff may approve minor modifications in the project design, but not the permitted land use (per MC 20.12). A change in an item requiring discretionary approval and any other changes deemed appropriate by the Planning staff shall require further Planning and Zoning Commission approval through the Design Review process.
- GEN-11 **Hold Harmless Agreement.** Pursuant to Government Code Section 66474.9, the applicant (including any agent thereof) shall defend, indemnify, and hold harmless, the City of Albany and its agents, officers and employees, from any claim, action, or proceeding against the City or its agents, officers or employees to attack, set aside, void, or annul the City's approval concerning this application, which action is brought within the time period provide for in Section 66499.37. The City will promptly notify the applicant of any such claim action or proceeding and cooperate fully in the defense.

- GEN-12 **Public Improvements Standards.** Public improvements shall be designed and constructed in accordance with the City's Standard Specifications and Standard Details, unless specifically waived in writing by the City Engineer.
- GEN-13 **Title 24 Standards.** All construction shall be designed and built in accordance with California Title 24 handicap accessibility standards. Appropriate details and specifications shall be incorporated into the plans and submitted at time of building permit application.
- GEN-14 **Energy Conservation Standards.** All buildings shall be designed in accordance with the State of California energy conservation standards for non-residential buildings. The necessary plans and documentation shall be submitted at time of building permit application.

ARCHITECTURE CONDITION

- ARCH-1 **Material Samples.** Descriptions or samples of final exterior materials and the proposed color palette shall be submitted for review and approval by the Community Development Department as part of building permit application.
- ARCH-2 **Final Architectural Drawings.** The applicant shall submit final architectural elevations, details and revisions for the review and approval of the Community Development Department as part of building permit application.
- ARCH-3 **Window Recess.** All new windows shall be recessed two inches from face of building to provide adequate shade and shadow and to promote visual relief. Final window details shall be submitted for review and approval at the time of building permit application.
- ARCH-4 **Non-Reflective Glazing.** Any glazing material shall be non-reflective.

LIGHTING CONDITIONS

- LGHT-1 **Exterior Lighting.** All exterior lighting shall be installed in such a manner that glare is directed away from surrounding properties and rights-of-way. If required, exterior light fixtures shall be equipped with "cut off" lenses to minimize light and glare spill over onto adjacent properties.
- LGHT-2 **Shielding of Lighting.** Prior to the certificate of occupancy, all accent lighting shall be directed downward and, if necessary, fixed with cut-off lenses to ensure that no glare spills onto neighboring properties.

LANDSCAPING CONDITIONS

- LNDS-1 **Street Tree Requirement.** The applicant shall apply for one street tree before the issuance of the building permit. The City's Environmental Resource Assistance

will determine the type and location of the tree and may waive this requirement if site conditions will not reasonably support establishment of a new tree.

PUBLIC WORKS DEPARTMENT CONDITIONS

GENERAL ENGINEERING CONDITIONS

- ENGR-1 **Title Report.** n/a.
- ENGR-2 **Geo-Technical Report.** The applicant shall submit, as part of a building permit application, a geotechnical investigation report prepared by a California certified engineering geologist and geotechnical engineer, if determined necessary by the City Engineer. The investigation shall specifically address any hazards of surface fault rupture in accordance with the Alquist-Priolo Special Study Zones Act. Any mitigation measures or conditions requiring further review noted during the Planning process shall be fully addressed prior to plan check.
- ENGR-3 **Backflow Device.** Any required water service for fire protection purposes shall be equipped with a City approved backflow device. Services for irrigation purposes also require a separate City approved backflow prevention device.

GRADING CONDITIONS

- GRAD-1 **Grading Permit.** Any grading required in association with the project shall require a grading permit from the Community Development Department. To obtain this permit, the applicant shall submit a grading plan, indicating the extent and volumes of earth proposed to be moved. A grading permit is subject to 2001 California Building, Appendix 33.
- GRAD-2 **Demolition Permit.** Site demolition shall not occur until construction permits are issued for the development project. All demolition shall be in accordance with permits issued by the City and Bay Area Air Quality Management District (BAAQMD).
- GRAD-3 **Water on Site.** The site shall be graded so as to prevent rainfall runoff originating from improved areas on the project site from crossing onto adjoining private property. Building floor elevations shall be above the FEMA-mapped 100-year flood plain as established by a licensed civil engineer. Provide the elevation and compaction certificates during and upon the completion of grading required by the Uniform Building Code and in conformance with the recommendations of the geotechnical engineer's report. Shore and dewater all excavations in accordance with the requirements of the geotechnical engineer's report.
- GRAD-4 **Flooding Damages.** The project developer shall execute an assumption of risk, indemnification and hold harmless agreement as required by the City. The agreement, in substance, shall state that the project developer, and any successor

in interest, shall assume all risk for damages to the project and to project improvements, flooding caused by surface water intrusion, stormwater runoff, or water under the ground surface pressing on or flowing or seeping through foundations, walls, floors, or paved surfaces, basements, whether paved or not, or windows, doors or other openings, and shall indemnify and hold the City harmless from any claims of such damages, including third-party claims, of such damage or of such damages or of damages arising from rainfall runoff which is not prevented from leaving the project site in violation of Condition GRAD-3.

GRAD-5 **Dust Control Program.** A dust control program shall be prepared by the project developer and approved by the Community Development Department and City Engineer before issuance of a grading permit. The dust control plan shall address such items as covering stockpiled material, frequent watering of graded areas, revegetating graded areas, speed limits for grading equipment and similar items.

GRAD-6 **Stormwater Pollution Prevention Plan.** The project developer shall submit a Stormwater Pollution Prevention Plan (SWPPP) for review by the City before the issuance of a building or grading and/or building permit. The SWPPP shall be consistent with standards adopted by the Regional Water Quality Control Board and the City of Albany Clean Water Program and implemented by the project general contractor, all subcontractors and suppliers of material and equipment. Construction site cleanup and control of construction shall also be addressed in the SWPPP. The project developer shall be responsible for SWPPP compliance. A copy of the SWPPP shall be kept at the construction site at all times.

INFRASTRUCTURE CONDITIONS

INFR-1 **Sewer System Requirements.** The sewer system for the subject building shall comply with Chapter 15 of the Albany Municipal Code and to the satisfaction of the City Engineer before Final Inspection approval of the construction permit.

INFR-2 **Two-Way Cleanout.** Installation of a two-way curbside cleanout shall be required per Chapter 15 of the Albany City Code. This applies to all properties, including properties with a valid upper sewer lateral certificate of compliance. All 2-way curbside clean outs shall be fitted with a loose cap in accordance with the City's standard detail SS6.

INFR-3 **Property Run-off Requirements.** All runoff from impervious surfaces shall be intercepted at the project boundary and shall be collected and conducted via an approved drainage system through the project site to an approved storm drain facility, as determined by the City Engineer. Development that contributes additional water to the existing drainage system shall be required to complete a hydraulic study and make improvements to the system as required to accommodate the expected ultimate peak water flow and to stabilize erosive banks that could be impacted by additional storm water flow.

INFR-4 **Roof Drainage.** Roof drainage from the structure shall be collected via a closed pipe and conveyed to an approved storm drain system off the street curb. No concentrated drainage of surface flow across sidewalks shall be permitted. Alternative natural treatment measures are subject review and approval by the City Engineer.

INFR-5 **Hydraulic Calculations.** The applicant shall submit hydraulic calculations, prepared by a California licensed civil engineer, necessary to determine if the existing water and sewer mains that serve this lot have available capacity for the addition of the proposed development. If capacity is not available, sewer and water mains of adequate size shall be designed and secured prior to issuance of building permits and constructed in a manner acceptable to the City Engineer prior to occupancy release, unless determined otherwise by the City Engineer.

INFR-6 **Completion of Off-Site Improvements.** Off-site improvements, as required by the City Engineer, shall be complete before issuance of a Certificate of Occupancy unless alternatives are approved in writing by the Albany City Engineer.

PUBLIC IMPROVEMENTS CONDITIONS

PUBIM-1 **Encroachment Permit.** The applicant shall obtain an encroachment permit from the Engineering Division before commencing any construction activities within any public right-of-way or easement.

PUBIM-2 **Debris Removal.** All mud, dirt or construction debris carried off the construction site onto adjacent streets shall be removed each day. No materials shall be discharged onto a sidewalk, street, gutter, storm drain or creek.

PUBIM-3 **Damage to Street Improvements.** Any damage to street improvements now existing or done during construction on or adjacent to the subject property, shall be repaired to the satisfaction of the City Engineer at the full expense of the applicant. This shall include sidewalk repair, slurry seal, street reconstruction or others, as may be required by the City Engineer.

PUBIM-4 **Right-of-Way Construction Standards.** All improvements within the public right-of-way, including curb, gutter, sidewalks, driveways, paving and utilities, shall be reconstructed in accordance with approved standards and/or plans and shall comply with the standard plans and specification of the Community Development Department and Chapter 14 of the City Code.

FIRE DEPARTMENT CONDITIONS

FIRE-1 **Construction of 1,500 Square Feet or Greater.** 1500 sq. ft. or more or any addition, remodel, rehabilitation, etc. is 50% of the existing sq. ft.:

- a) This dwelling will be required install an Automatic Fire Extinguishing System throughout the entire dwelling. Ordinance No. 94-010, Albany Municipal Code, Chapter 11, Section 11-2.3a(3)(a).
- b) Plans, information sheets on all sprinkler components and hydraulic calculations are required.
- c) A 110-volt interconnected smoke alarm system with a 10-year lithium battery back-up is acceptable with a fire suppression system.

FIRE-2 **Fire Rated Construction.** Any portion of a building five (5) feet or less from the property line shall comply with fire-rating requirements of the CBC.

FIRE-3 **Gallons-per-Minute Requirement.** The water system for fire protection shall comply with City of Albany Fire Department standards. Fire flow test data and water system plans must be provided at time of building plan check. The plans must include all equipment, components and layout of the system. Private fire protection water systems shall be supplied through an approved backflow device per City Engineering Division standards.

FIRE-5 **Distance From Fire Hydrant.** Before building permit issuance the distance from existing fire hydrants to the building shall be verified and if necessary, a new hydrant shall be shown on the plans and installed prior to combustible construction.

STRUCTURAL CONTROL MEASURES

STRUC-1 **Illegal Dumping to Storm Drain Inlets and Waterways.** On-site storm drain inlets shall be clearly marked with the words “No Dumping! Flows to Bay,” or equivalent, using methods approved by the City of Albany.

STRUC-2 **Pesticide/Fertilizer Application** Landscaping shall be designed to minimize irrigation and runoff, promote surface infiltration where appropriate, and minimize the use of fertilizers and pesticides that can contribute to stormwater pollution. If a landscaping plan is required as part of a development project application, the plan shall meet the following conditions related to reduction of pesticide use on the project site:

- a) Where feasible, landscaping shall be designed and operated to treat stormwater runoff by incorporating elements that collect, detain, and infiltrate runoff. In areas that provide detention of water, plants that are tolerant of saturated soil conditions and prolonged exposure to water shall be specified.
- b) Plant materials selected shall be appropriate to site specific characteristics such as soil type, topography, climate, amount and timing of sunlight, prevailing winds, rainfall, air movement, patterns of land use, ecological consistency and plant interactions to ensure successful establishment.
- c) Existing native trees, shrubs, and ground cover shall be retained and incorporated into the landscape plan to the maximum extent practicable.

- d) Proper maintenance of landscaping, with minimal pesticide use, shall be the responsibility of the property owner.

OPERATIONAL BEST MANAGEMENT PRACTICES (BMPs)

- BMP-GEN1 Stormwater Pollution Prevention Control Measures.** The project plans shall include stormwater pollution prevention and control measures for the operation and maintenance of the project during and after construction for the review and approval of the City or County Engineer. The project plan shall identify Best Management Practices (BMPs) appropriate to the uses conducted on-site in order to limit to the maximum extent practicable the entry of pollutants into stormwater runoff.
- BMP-GEN2 Erosion Control Measures.** The project plan shall also include erosion control measures to prevent soil, dirt and debris from entering the storm drain system, in accordance with the practices outlined in the *ABAG Erosion and Sediment Control Handbook*, *California Storm Water Best Management Practice Handbooks*, and *Regional Water Quality Control Board's Erosion and Sediment Control Field Manual*
- BMP-GEN3 Responsibility of Contractors.** The applicant is responsible for ensuring that all contractors and subcontractors are aware of and implement all stormwater quality control measures. Failure to comply with the approved construction BMPs shall result in the issuance of correction notices, citations and/or a project stop order.
- BMP-1 Paved Sidewalks and Parking Lots.** Sidewalks and parking lots shall be swept regularly to prevent the accumulation of litter and debris. Debris resulting from pressure washing shall be trapped and collected to prevent entry into the storm drain system. Washwater containing any soap, cleaning agent or degreaser shall be collected and discharged to the sanitary sewer and shall not be discharged to a storm drain. The applicant shall contact the City Engineer for specific connection and discharge requirements.
- BMP-2A Private Streets, Utilities and Common Areas.** The owner of private streets and storm drains shall prepare and implement a plan for street sweeping of paved private roads and cleaning of all storm drain inlets.

GENERAL CONSTRUCTION BEST MANAGEMENT PRACTICES (BMPs)

- BMP-CNST1 Construction Access Routes.** Construction access routes shall be limited to those approved by the City Engineer and shall be shown on the approval grading plan.
- BMP-CNST2 Collection of Construction Debris.** Gather all construction debris on a regular basis and place them in a dumpster or other container that is emptied or removed on a weekly basis. When appropriate, use tarps on the ground to collect fallen debris or splatters that could contribute to stormwater pollution.

- BMP-CNST3 **Removal of Waste.** Remove all dirt, gravel, rubbish, refuse and green waste from the sidewalk, street pavement, and storm drain system adjoining the project site. During wet weather, avoid driving vehicles off paved areas and other outdoor work.
- BMP-CNST4 **Sweeping of Public Right-of-Way.** Broom sweep the sidewalk and public street pavement adjoining the project site on a daily basis. Caked on mud or dirt shall be scraped from these areas before sweeping.
- BMP-CNST5 **Filter Materials at Storm Drain Inlet.** Install filter materials (such as sandbags, filter fabric, etc.) at the storm drain inlet nearest the downstream side of the project site prior to:
- a) start of the rainy season (October 1);
 - b) site dewatering activities;
 - c) street washing activities;
 - d) saw cutting asphalt or concrete; and
 - e) order to retain any debris or dirt flowing into the City storm drain system.
- Filter materials shall be maintained and/or replaced as necessary to ensure effectiveness and prevent street flooding. Dispose of filter particles in the trash.
- BMP-CNST6 **Containment of Materials.** Create a contained and covered area on the site for the storage of bags of cement, paints, flammables, oils, fertilizers, pesticides, or any other materials used on the project site that have the potential for being discharged to the storm drain system by wind or in the event of a material spill.
- BMP-CNST7 **Cleaning of Equipment.** Never clean machinery, tools, brushes, etc. or rinse containers into a street, gutter, storm drain or stream. See the *Building Maintenance/ Remodeling* flyer for more information.
- BMP-CNST8 **Minimize Removal of Natural Vegetation.** Minimize removal of natural vegetation or ground cover from the site in order to minimize the potential for erosion and sedimentation problems. Replant the area as soon as possible. All cut and fill slopes shall be stabilized as soon as possible after grading is completed. No site grading shall occur between October 1 and April 15 unless approved erosion and sedimentation control measures are in place.

SPECIAL CONDITIONS

SPECIAL 1 **none.**

Appeals:

The Albany Municipal Code provides that any action of the Planning and Zoning Commission may be appealed to the City Council if such appeal is filed within 14 calendar days of the date of action. Appeals may be filed in the Community Development Department by completing the

required form and paying the required fee. The City Clerk will then schedule the matter for the next available City Council meeting.

Planning Application #: 12-023

Date Received: 5/24/12
 Fee Paid: \$1,784.00
 Receipt #: 75803



City of Albany

PLANNING APPLICATION FORM

Please complete the following application to initiate City review of your application. Please be aware that staff may have additional application requirements. For projects requiring Planning and Zoning Commission review, please schedule an appointment with Planning Division staff. The Community Development Department office is open to accept applications Monday, 8:30 AM to 7:00 PM, Tuesday through Thursday 8:30 AM to 5:00 PM, and Friday 8:30 AM to 12:30 PM at 1000 San Pablo Avenue, Albany, CA 94706 (510) 528-5760.

Fee Schedule (FY 2009-2010)

<input checked="" type="checkbox"/> Design Review*	\$1,784 / Admin. \$639
<input type="checkbox"/> Parking Exceptions/Reductions - see separate handout*	\$Actual Cost/Min \$1,784
<input type="checkbox"/> Conditional Use Permit (major)*	\$Actual Cost/Min \$1,784
<input type="checkbox"/> Conditional Use Permit (minor)*	\$620
<input type="checkbox"/> Sign Permit	\$1,185/\$423 Admin.
<input type="checkbox"/> Temporary/Seasonal Conditional Use Permit*	\$300
<input type="checkbox"/> Parcel/Subdivision Map; Lot Line Adjustment; Condo Conversion*	\$Actual Cost/Min \$1,784
<input type="checkbox"/> Secondary Residential Unit*	\$455
<input type="checkbox"/> Planned Unit Development*	\$1,784
<input type="checkbox"/> Variance*	\$1,784
<input type="checkbox"/> Other(s): _____	\$ _____

*When obtaining more than one planning approval, the full amount for the highest fee will apply and 1/2 fee will be charged for any other ones. General Plan Update Fee \$45 included in the fees above. This fee only needs to be paid once for each separately submitted application.

Job Site Address: <u>812 RAMONA AVE, ALBANY</u>		Zoning District: <u>R-1</u>
Property Owner(s) Name: <u>CAROLINA BALAZS</u> <u>DAVID GUENDELMAN</u>	Phone: <u>510 978 6619</u> Fax:	Email: <u>CAROLINA BALAZS</u> <u>@GMAIL.COM</u>
Mailing Address: <u>SAME AS</u> <u>APPLICANT</u>	City:	State/Zip:
Applicant(s) Name (contact person): <u>SANTIAGO- LEON BALAZS</u>	Phone: <u>(510) 525 8897</u> Fax: <u>(510) 525 8897</u>	Email: <u>leonbalazs@yahoo.com</u>
Mailing Address: <u>P.O. BOX #7163, BERKELEY, CA</u>	City: <u>BERKELEY</u>	State/Zip: <u>94707</u>

PROJECT DESCRIPTION (Please attach plans if required)

WORK TO INCLUDE THE REMODEL OF AN EXISTING S.F. HOME
AT ABOVE ADDRESS AND AN ADDITION TO EXISTING FIRST FLOOR PLAN
PLUS A SECOND FLOOR

PROJECT ADDRESS: _____

GENERAL INFORMATION (Please fill out this Chart or attach separate plans with information)

Item	Existing	Proposed
Lot Size? (Express in square feet) <i>5000.00 SQ. FT.</i>	<i>5,000</i>	<i>5,000</i>
Gross square footage of all building area (including detached & accessory buildings, garages, etc.)	<i>1,129</i>	<i>2,498</i>
What is the Floor Area Ratio (FAR) (see handout on how to measure for residential projects)		
What is your lot coverage?	<i>1,129</i>	<i>1,767</i>
What is the amount of impervious surface on the lot? <i>see separate sheet</i>	<i>1,129</i>	<i>1,522</i>
What is the maximum height of the building? (see handout on how to measure for residential projects)	<i>13'-0"</i>	<i>22'-3"</i>
How many dwelling units are on your property?	<i>1</i>	<i>1</i>
How many off-street parking spaces do you have? (front yard parking is not counted unless previously approved by the City)	<i>2</i>	<i>2</i>
What are the dimensions of parking spaces? (give interior dimensions of enclosed parking spaces)	<i>18'-0" X 8'-6"</i>	<i>18'-0" X 8'-6"</i>
What is the narrowest width of your driveway?	<i>12'-0"</i>	<i>8'-6"</i>
Minimum setbacks from structure to property line		
Front yard:	<i>15-0</i>	<i>15-0</i>
Side yards:	<i>6-3</i>	<i>5-0</i>
Rear Yard:	<i>40'-0"</i>	<i>36'-0"</i>

TERMS AND CONDITIONS OF APPLICATION

I, the undersigned owner (or authorized agent) of the property herein described, hereby make application for approval of the plans submitted and made part of this application in accordance with the provisions of the City's ordinances, and I hereby certify that the information given is true and correct to the best of my knowledge and belief.

I understand that the requested approval is for my benefit (or that of my principal). Therefore, if the City grants the approval with or without conditions, and that action is challenged by a third party, I will be responsible for defending against this challenge. I therefore agree to accept this responsibility for defense at the request of the City and also agree to defend, indemnify and hold the City harmless from any costs, claims, penalties, fines, judgments, or liabilities arising from the approval, including without limitation, any award or attorney's fees that might result from the third party challenge.

For this purposes of this indemnity, the term "City" shall include the City of Albany, its officers, officials, employees, agents and representatives. For purposes of this indemnity, the term "challenge" means any legal or administrative action to dispute, contest, attack, set aside, limit, or modify the approval, project conditions, or any act upon which the approval is based, including any action alleging a failure to comply with the California Environmental Quality Act or other laws.

The signature of the property owner is required for all projects. By executing this form you are affirming that you are the property owner.

Calif Rap

Signature of Property Owner *5/23/12*
Date

[Signature]

Signature of Applicant (if different) *5/24/12*
Date

MAY 24 2012

COMMUNITY DEVELOPMENT DEPARTMENT



City of Albany

Green Building Program Rating System for Remodeling Projects* Supplemental Application Form

*Please obtain other appropriate Green Point Checklist for projects other than Single Family Residential Remodeling Projects

Project Address: 812 RAMONA AVE

Checklist Prepared By: SANTIAGO LEON BALAZS

Date Prepared: 5/24/12

	INPUT	Resources	Energy	IAQ/Health
--	-------	-----------	--------	------------

A. Site

1. Recycle Job Site Construction & Demolition Waste 65% = 1 point; 75% = 2 points; 80% = 4 points	up to 4 Resource pts			
2. Salvage Reusable Building Materials	4 Resource pts y=yes	Y	4	
3. Remodel for Mixed Use, Adaptive Reuse, and Historic Preservation	4 Resource pts y=yes			
4. Protect Native Soil	2 Resource pts y=yes			
5. Minimize Disruption of Existing Plants & Trees	1 Resource pt y=yes			
6. Implement Construction Site Stormwater Practices	2 Resource pts y=yes			
7. Protect Water Quality with Landscape Design	2 Resource pts y=yes	Y		2
8. Design Resource-Efficient Landscapes and Gardens	4 Resource pts y=yes	Y	4	
9. Reuse Materials/Use Recycled Content Materials for Landscape Areas	2 Resource pts y=yes			
10. Install High-Efficiency Irrigation Systems	2 Resource pts y=yes	Y		2
11. Provide for On-Site Water Catchment / Retention	2 Resource pts y=yes			

B. Foundation

1. Incorporate Recycled Flyash in Concrete 25% Recycled Flyash = 2 points; Add 1 point for every 10% increase of flyash, up to 5 points	up to 5 Resource pts			
2. Use Recycled Content Aggregate	2 Resource pts y=yes			
3. Insulate Foundation/Slab before backfill	3 Energy pts y=yes	Y		3

C. Structural Frame

1. Substitute Solid Sawn Lumber with Engineered Lumber	3 Resource pts y=yes			
2. Use FSC Certified Wood for framing (For every 10% of FSC lumber used = 2 points, up to 10)	up to 10 Resource pts	Y	4	
3. Use Wood I-Joists for Floors and Ceilings	2 Resource pts y=yes	Y	2	
4. Use Web Floor Trusses	2 Resource pts y=yes	Y	2	
5. Design Energy Heels on Trusses 6" or more	2 Energy pts y=yes			
6. Use Finger-Jointed Studs for Vertical Applications	2 Resource pts y=yes			
7. Use Engineered Studs for Vertical Applications	2 Resource pts y=yes			
8. Use Recycled Content Steel Studs for Interior Framing	2 Resource pts y=yes			
9. Use Structural Insulated Panels (SIPs)				
a. Floors	3 Energy pts y=yes	Y		3
b. Wall	3 Energy pts y=yes	Y		3
c. Roof	3 Energy pts y=yes	Y		3

2004 Checklist Modified by City of Albany Incentives - Approved July 2, 2007

			INPUT	Resources	Energy	IAQ/Health
10. Apply Advanced Framing Techniques	4 Resource pts	y=yes				
11. Use Reclaimed Lumber for Non Structural Applications	3 Resource pts	y=yes				
12. Use OSB						
a. Subfloors	1 Resource pt	y=yes				
b. Sheathing	1 Resource pt	y=yes				

D. Exterior Finish

1. Use Sustainable Decking Materials						
a. Recycled content	3 Resource pts	y=yes				
b. FSC Certified Wood	3 Resource pts	y=yes				
2. Use Treated Wood That Does Not Contain Chromium/Arsenic	1 IAQ/Health pt	y=yes	Y		1	
3. Install House Wrap under Siding	1 IAQ/Health pt	y=yes				
4. Use Fiber-Cement Siding Materials	1 Resource pt	y=yes				

E. Plumbing

1. Install Water Heater Jacket	1 Energy pt	y=yes	Y		1	
2. Insulate Hot and Cold Water Pipes	2 Energy pts	y=yes	Y		2	
3. Retrofit all Faucets and Showerheads with Flow Reducers						
a. Faucets (1 point each, up to 2 points)	Up to 2 Resource pts.		Y		2	
b. Showerheads (1 point each, up to 2 points)	Up to 2 Resource pts.					
4. Replace Toilets with Ultra-Low Flush Toilets (1 point each, up to 3 points)	Up to 3 Resource pts.		Y		3	
5. Install Chlorine Filter on Showerhead	1 IAQ/Health pt	y=yes				
6. Convert Gas to Tankless Water Heater	4 Energy pts	y=yes	Y		4	
7. Install Water Filtration Units at Faucets (2 points each, up to 4 points)	Up to 4 IAQ/Health pts.		Y		4	
8. Install On-Demand Hot Water Circulation Pump	4 Resource pts	y=yes				

F. Electrical

1. Install Compact Fluorescent Light Bulbs (CFLs) (6 bulbs=2 points, 10 bulbs =3 points, 12 bulbs = 4 points)	Up to 4 Energy pts.		Y		4	
2. Install IC-AT Recessed Fixtures with CFLs (1 point each, up to 5 points)	Up to 5 Energy pts.		Y		5	
3. Install Lighting Controls (1 point per fixture, up to 4 points)	Up to 4 Energy pts.					
4. Install High Efficiency Ceiling Fans with CFLs (1 point each, up to 4 points)	Up to 4 Energy pts.					

G. Appliances

1. Install Energy Star Dishwasher	1 Energy pt	y=yes	Y		1	
2. Install Washing Machine with Water and Energy Conservation Features	1 Energy pt	y=yes	Y		1	
3. Install Energy Star Refrigerator	1 Energy pt	y=yes	Y		1	
4. Install Built-In Recycling Center	3 Resource pts	y=yes				

H. Insulation

1. Upgrade Insulation to Exceed Title 24 Requirements						
a. Walls	2 Energy pts	y=yes	Y		2	
b. Ceilings	2 Energy pts	y=yes	Y		2	

			INPUT	Resources	Energy	IAQ/Health
2. Install Floor Insulation over Crawl Space	4 Energy pts	y=yes	Y		4	
3. Install Recycled-Content, Fiberglass Insulation with No Added Formaldehyde	3 IAQ/Health pts	y=yes				
4. Use Advanced Infiltration Reduction Practices	2 Energy pts	y=yes				
5. Use Cellulose Insulation						
a. Walls	4 Resource pts	y=yes				
b. Ceilings	4 Resource pts	y=yes				
6. Alternative Insulation Products (Cotton, spray-foam)						
a. Walls	4 Resource pts	y=yes				
b. Ceilings	4 Resource pts	y=yes				
I. Windows						
1. Install Energy-Efficient Windows			✓			
a. Double-Paned	1 Energy pt	y=yes	Y		2	
b. Low-Emissivity (Low-E)	2 Energy pts	y=yes			2	
c. Low. Conductivity Frames	2 Energy pts	y=yes				
2. Install Low Heat Transmission Glazing	1 Energy pt	y=yes				
J. Heating Ventilation and Air Conditioning						
1. Use Duct Mastic on All Duct Joints	2 Energy pts	y=yes	Y		2	
2. Install Ductwork within Conditioned Space	3 Energy pts	y=yes				
3. Vent Range Hood to the Outside	1 IAQ/Health pt	y=yes	Y		1	
4. Clean all Ducts Before Occupancy	2 IAQ/Health pts	y=yes				
5. Install Solar Attic Fan	2 Energy pts	y=yes	Y		2	
6. Install Attic Ventilation Systems	1 Energy pt	y=yes				
7. Install Whole House Fan	4 Energy pts	y=yes				
8. Install Sealed Combustion Units						
a. Furnaces	3 IAQ/Health pts	y=yes	Y		3	
b. Water Heaters	3 IAQ/Health pts	y=yes	Y		3	
9. Replace Wall-Mounted Electric and Gas Heaters with Through-the-Wall Heat Pumps	3 Energy pts	y=yes				
10. Install 13 SEER/11 EER or higher AC with a TXV	3 Energy pts	y=yes				
11. Install AC with Non-HCFC Refrigerants	2 Resource pts	y=yes				
12. Install 90% Annual Fuel Utilization Efficiency (AFUE) Furnace	2 Energy pts	y=yes	Y		2	
13. Retrofit Wood Burning Fireplaces						
a. Install EPA certified wood stoves/inserts	1 IAQ/Health pt	y=yes				
b. Install/Replace Dampers	1 Energy pt	y=yes				
c. Install Airtight Doors	1 Energy pt	y=yes				
14. Install Zoned, Hydronic Radiant Heating	3 Energy pts	y=yes	Y		3	
15. Install High Efficiency Filter	4 IAQ/Health pts	y=yes				
16. Install Heat Recovery Ventilation Unit (HRV)	5 IAQ/Health pts	y=yes				
17. Install Separate Garage Exhaust Fan	3 IAQ/Health pts	y=yes	Y		2	3
K. Renewable Energy and Roofing						
1. Pre-Plumb for Solar Water Heating	4 Energy pts	y=yes	Y		4	
2. Install Solar Water Heating System	10 Energy pts	y=yes	Y		10	
3. Pre-Wire for Future Photovoltaic (PV) Installation	4 Energy pts	y=yes				
4. Install Photovoltaic (PV) System (1.2 kw = 6 points, 2.4 kw = 12 points, 3.6 kw = 18 points)	Up to 18 Energy pts					

2004 Checklist Modified by City of Albany Incentives - Approved July 2, 2007

			INPUT	Resources	Energy	IAQ/Health
6. Select Safe and Durable Roofing Materials	1 Resource pt	y=yes	Y	1		
7. Install Radiant Barrier	3 Energy pts	y=yes				

L. Natural Heating and Cooling

1. Incorporate Passive Solar Heating	5 Energy pts	y=yes	Y		5	
2. Install Overhangs or Awnings over South Facing Windows	3 Energy pts	y=yes	Y		3	
3. Plant Deciduous Trees on the West and South Sides	3 Energy pts	y=yes				

M. Indoor Air Quality and Finishes

1. Use Low/No-VOC Paint	1 IAQ/Health pts	y=yes	Y			1
2. Use Low VOC, Water-Based Wood Finishes	2 IAQ/Health pts	y=yes	Y			1
3. Use Low/No VOC Adhesives	3 IAQ/Health pts	y=yes	Y			1
4. Use Salvaged Materials for Interior Finishes	3 Resource pts	y=yes				
5. Use Engineered Sheet Goods with no added Urea Formaldehyde	6 IAQ/Health pts	y=yes				
6. Use Exterior Grade Plywood for Interior Uses	1 IAQ/Health pts	y=yes				
7. Seal all Exposed Particleboard or MDF	4 IAQ/Health pts	y=yes				
8. Use FSC Certified Materials for Interior Finish	4 Resource pts	y=yes	Y	4		
9. Use Finger-Jointed or Recycled-Content Trim	1 Resource pts	y=yes				
10. Install Whole House Vacuum System	3 IAQ/Health pts	y=yes	Y			3

N. Flooring

1. Select FSC Certified Wood Flooring	8 Resource pts	y=yes	Y	8	*	
2. Use Rapidly Renewable Flooring Materials	4 Resource pts	y=yes				
3. Use Recycled Content Ceramic Tiles	4 Resource pts	y=yes				
4. Install Natural Linoleum in Place of Vinyl	5 IAQ/Health pts	y=yes				
5. Use Exposed Concrete as Finished Floor	4 Resource pts	y=yes	Y		4	
6. Install Recycled Content Carpet with Low VOCs	4 Resource pts	y=yes				

O. City of Albany Incentives

1. Additions less than 50% increase in floor area	20 Resource pts	y=yes				
2. Additions less than 200sq.ft. or resulting in less than 1,500sq.ft.	10 Resource pts	y=yes				
3. Seismic upgrade of existing building	25 Resource pts	y=yes				
4. For having a hybrid or zero emissions vehicle	2 IAQ/Health pts	y=yes				
5. For having no automobile	5 Resource pts	y=yes				
6. Plant more than one street tree when feasible	2 IAQ/Health pts	y=yes	Y			2
7. Earthquake kit	2 IAQ/Health pts	y=yes	Y			2

TOTAL POINTS ACCUMULATED:

50 points total Req'd

27

(50 Points REQUIRED from all 3 columns)

JUL 18 2012

COMMUNITY DEVELOPMENT
DEPARTMENT

CLAD ULTIMATE DOUBLE HUNG

CONSTRUCTION DETAILS

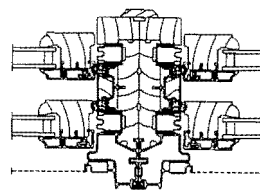
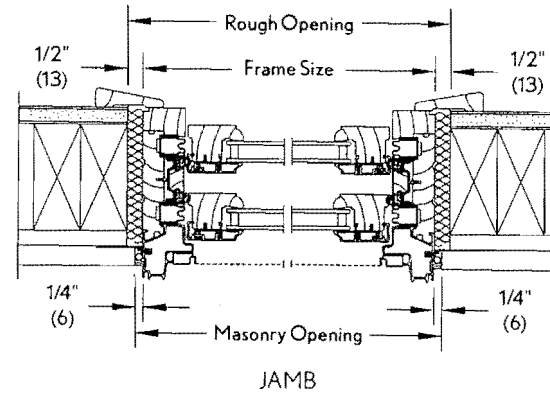
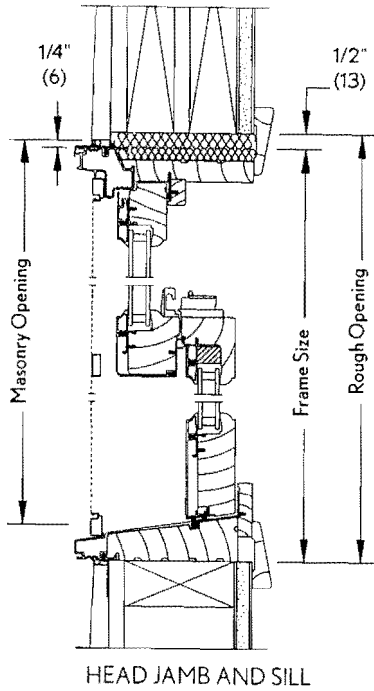

DESIGNER:
Santiago-Leon Balazs
1734 SOLANO AVENUE
BERKELEY CA 94707
(510) 525-8897

REMODEL AND ADDITION FOR RESIDENCE OF:
David Guendelman and Carolina Balazs
812 RAMONA AVENUE
ALBANY CA 94706

SHEET TITLE:
ELEVATIONS
WINDOW DETAIL

Date: 05/24/12
Scale: 1/4" = 1'-0"
Drawn by: DMS
Job name: BALAZS

SHEET NO
A 3.1
OF 10 SHEETS

WOOD TILT TURN AND HOPPER

CONSTRUCTION DETAILS

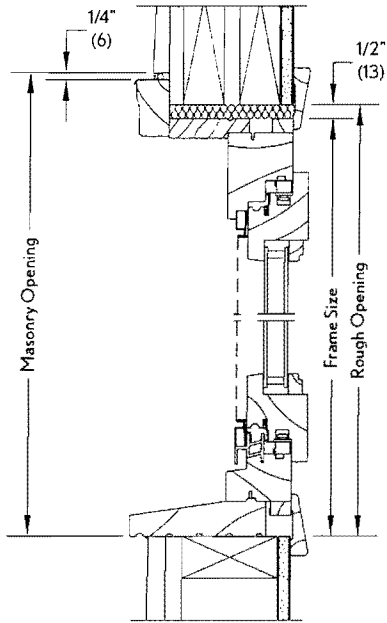

WOOD OPERATOR HEAD JAMB AND SILL
2X4 FRAME CONSTRUCTION

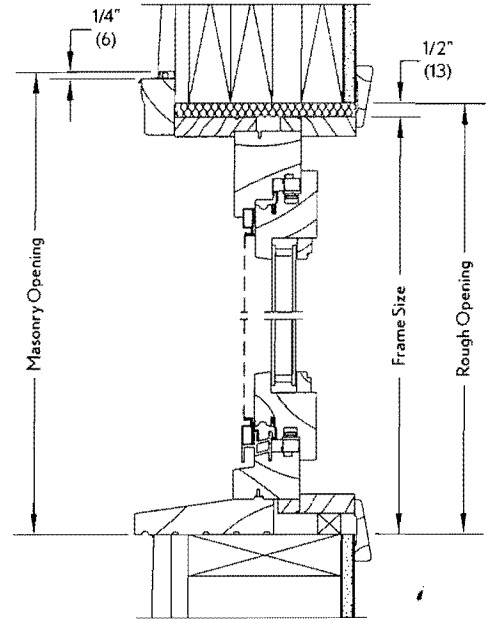

WOOD OPERATOR HEAD JAMB AND SILL
2X6 FRAME CONSTRUCTION

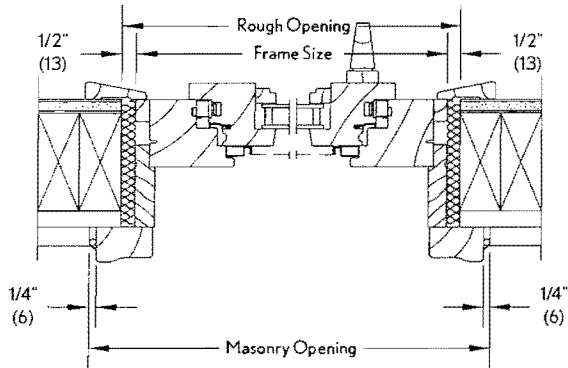

WOOD OPERATOR JAMB
2X4 FRAME CONSTRUCTION

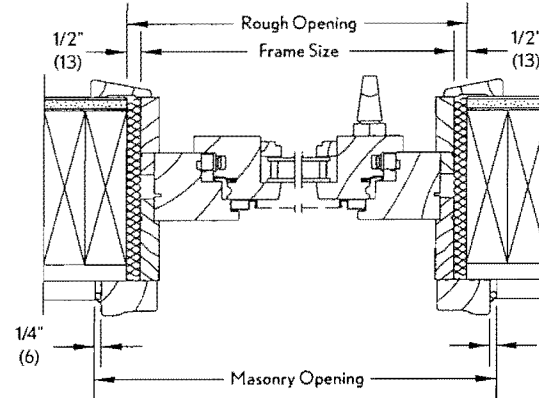

WOOD OPERATOR JAMB
2X6 FRAME CONSTRUCTION

WOOD TILT TURN/HOPPER

ENERGY DATA	U-Factor	SHGC	VT	CR	ENERGY STAR
7/8" IG Air	0.41	0.5	0.53	46	
7/8" IG LoE 272 Air	0.31	0.27	0.46	58	NC, SC, S
7/8" IG LoE 272 Argon	0.28	0.27	0.46	61	N, NC, SC, S
7/8" IG LoE 366 Air	0.3	0.18	0.42	58	N, NC, SC, S
7/8" IG LoE 366 Argon	0.27	0.18	0.42	62	N, NC, SC, S

CITY OF ALBANY

JUL 18 2012

**COMMUNITY DEVELOPMENT
DEPARTMENT**

A 3.2	SHEET NO.	Date: 05/24/12 Scale: 1/4" = 1'-0" Drawn by: DMS Job name: BALAZS	SHEET TITLE:	REMODEL AND ADDITION FOR RESIDENCE OF:	DESIGNER:	
			ELEVATIONS <u>WINDOW DETAIL</u>	David Guendelman and Carolina Balazs 812 RAMONA AVENUE ALBANY CA 94706	Santiago-Leon Balazs 1734 SOLANO AVENUE BERKELEY CA 94707 (510) 525-8897	

MARVIN 
Windows and Doors

Built around you.®

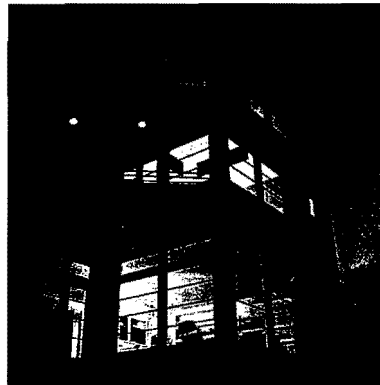
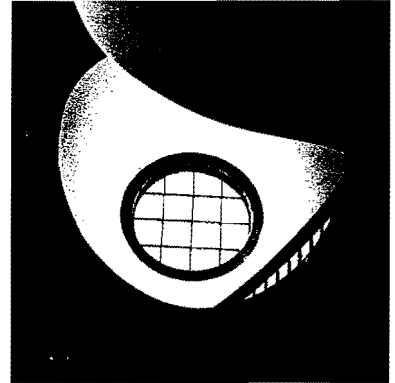

CITY OF ALBANY

JUL 18 2012

**COMMUNITY DEVELOPMENT
DEPARTMENT**

Product Catalog

812 Ramona Story Poles











August 31, 2012

To the Albany Design Review Committee:

We are pleased to submit our design review proposal for our home at 812 Ramona Ave in Albany, California. We both grew up just a few blocks away, in Berkeley and have lived in this area practically our whole lives. We are excited to raise our kids near our families, and to send them to Albany's schools. We love Albany's feeling of community, walkability and neighborliness and are very excited to live here. Since we both work from home, our home expansion plans are meant to accommodate our future kids and our home-office needs.

Our home—a Latin American/California fusion—incorporates our love for community, our lifestyle and our family roots. While we both grew up in the East Bay, both of our families are from South America. Thus we wanted our home to reflect our California-Latin American fusion. We've worked closely over the last few years (with Carolina's father, the architect!) to develop a design that melds Northern California's own rich architectural history, which includes the Spanish-Mexican-California colonial style, with a colonial-Colombian blend, given our family's heritage. This style fits nicely with the neighborhood's Spanish-style homes.

To accentuate the home's style, we will have bougainvillea vines growing along the front balcony that hangs over the home's entrance, and plan to plant a diversity of drought-tolerant and tropics-reminiscent trees, shrubs and grasses. The home's off-white white-washed walls will be complemented with grey-blue window trim, which together with the abundant greenery that we plan to plant will add visual relief from the street, and a sense of peace and calm. Along the sides of the house, we will have trellises along the walls and plant additional shrubbery and vegetation to add visual connectivity and aesthetic relief for passersby and neighbors. Having sought to retain as much of the backyard area as possible, we will plant additional trees and shrubs and grow vegetables.

We look forward to discussing the details at the upcoming Design Review, and thank you for your time and consideration.

Sincerely,

Carolina Balazs & David Guendelman