

shaping the wireless world™

CROWN
CASTLE
INTERNATIONAL

Crown Castle – Wireless Facility at 423 San Pablo
Project No. 11-004

Project Description

- The Project consists of replacing four (4) existing panels with four (4) new ones
- The original grant was authorized by the PUC for six, 6 foot panels
- The panels were replaced approximately 6 years ago in connection with the EVDO maintenance upgrade which brought better service to the community. The replacement panels consisted of four, 48 inch panels
- The Project requests permission to replace those panels with new ones of a similar shape and size, and therefore, is within the scope of the original grant

Staff Recommendation

- Substantial evidence is required to support the finding that:
 - 1) strict compliance with the Planning and Zoning Code would not provide for adequate radio-frequency signal reception; and
 - 2) that no other alternative solutions that would meet the development standards are feasible.

Alternative Solutions Analysis

- Reduce Pole Height to Comply with Municipal Code (48 foot maximum)
- Relocate VZW's Facility to Existing Buildings
- Relocate VZW's Facility to Other Existing Sites

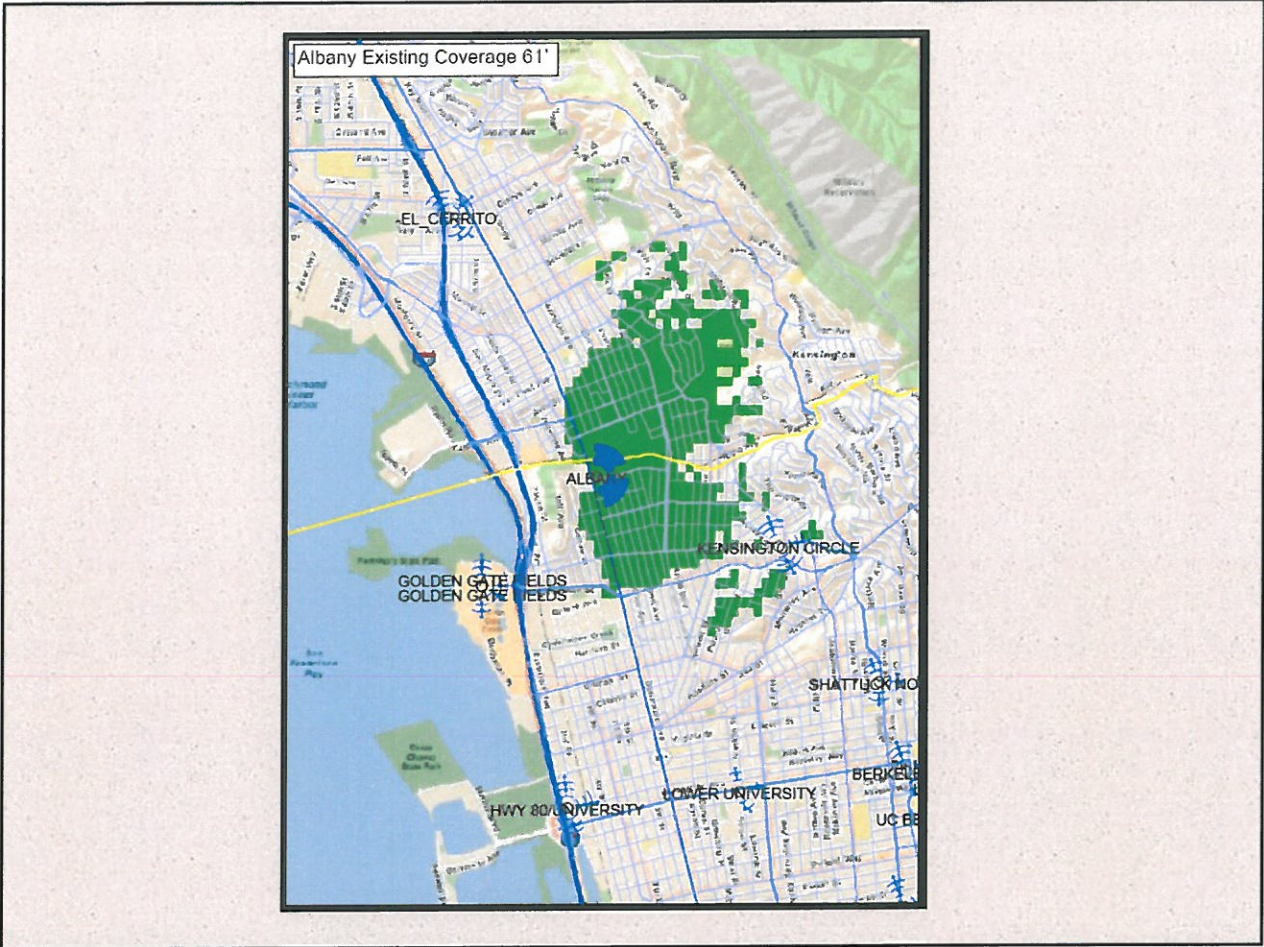

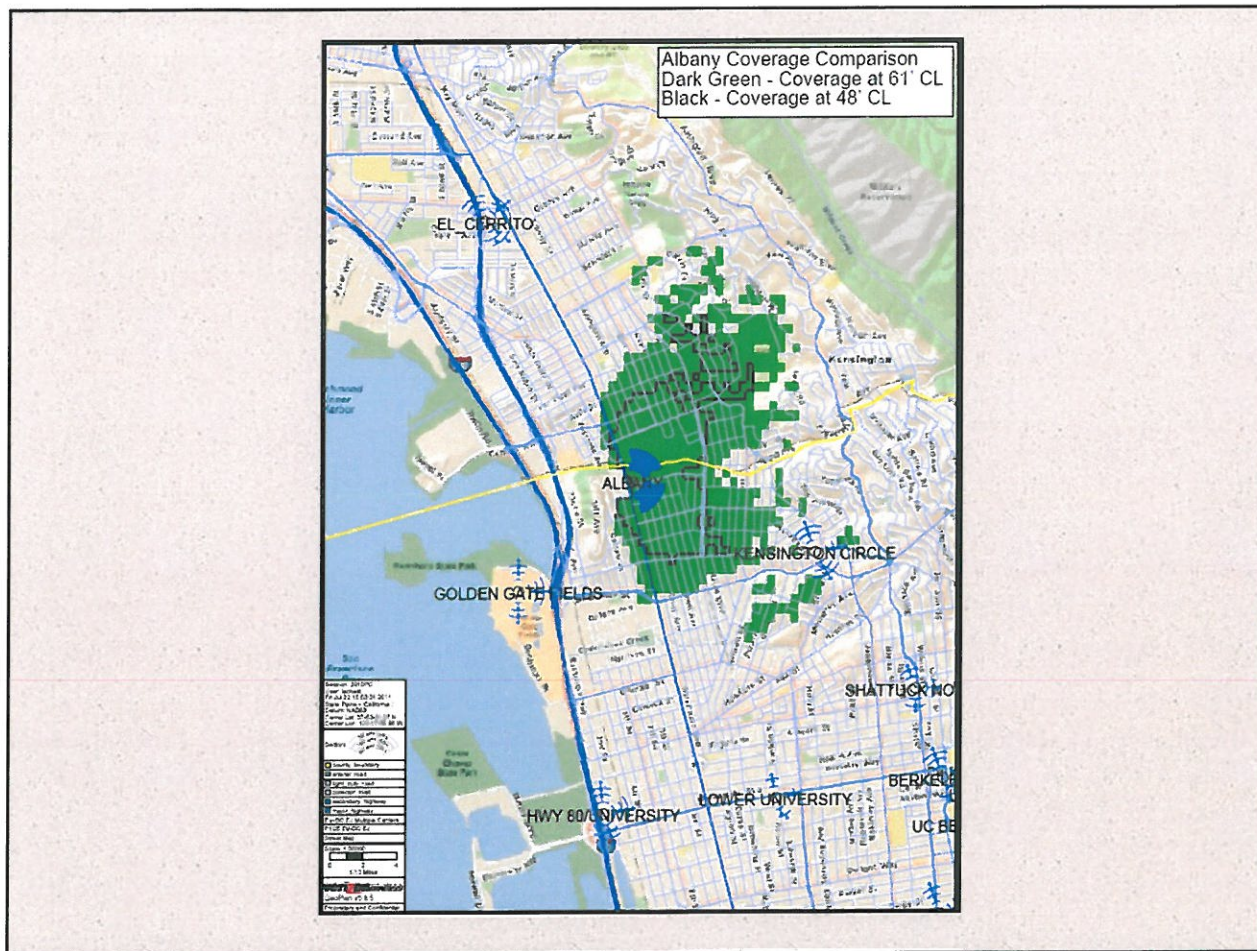





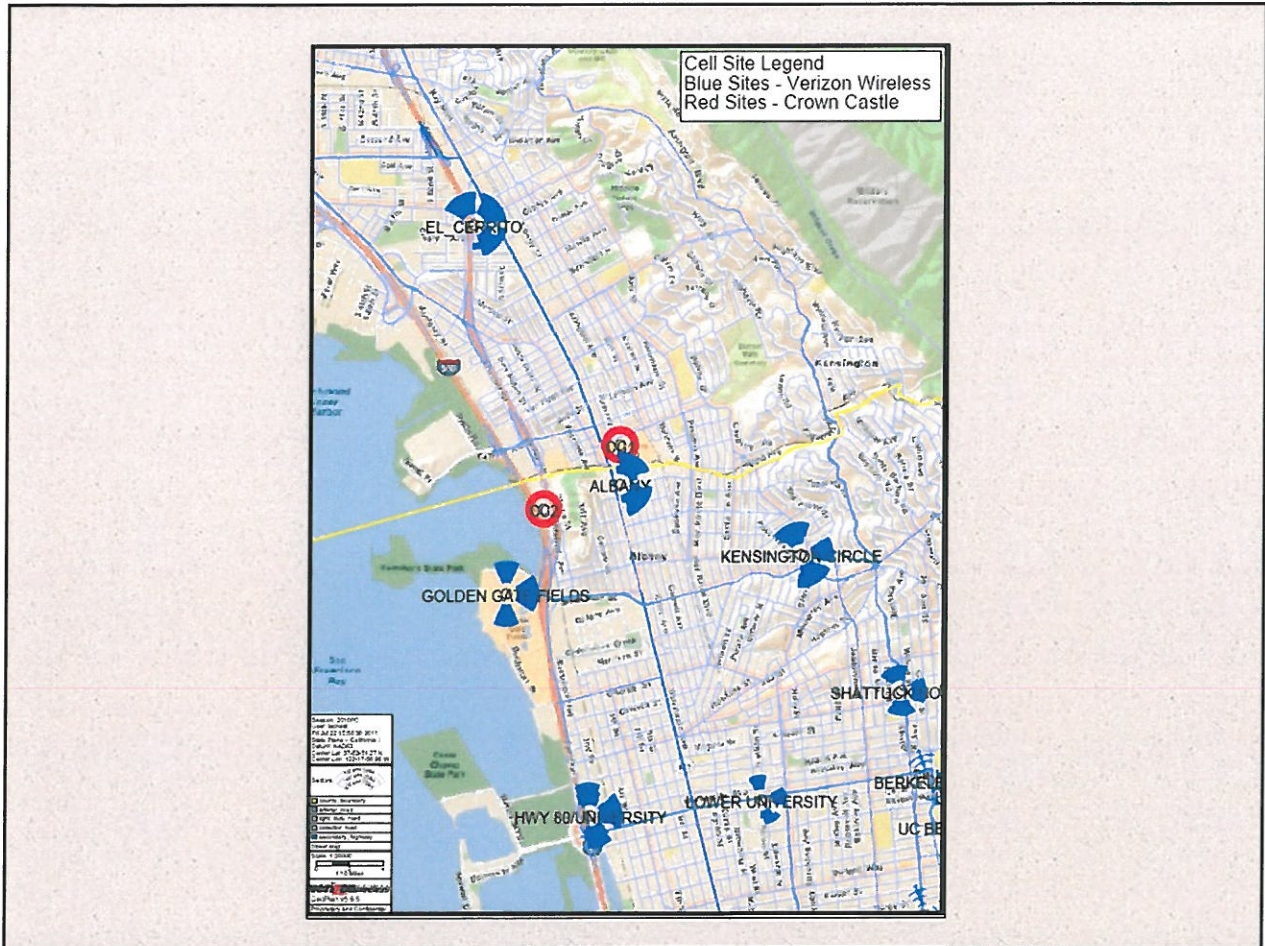

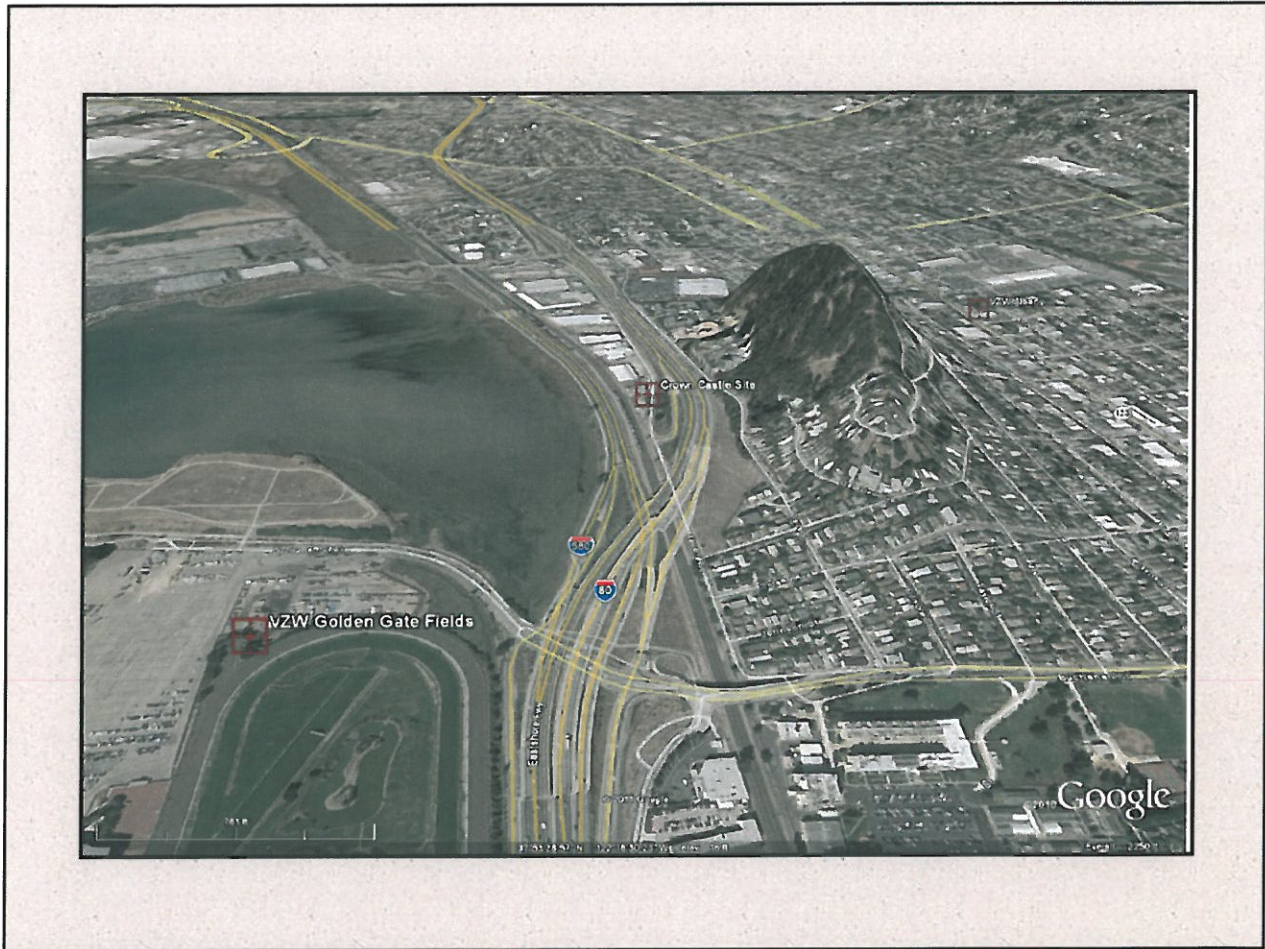

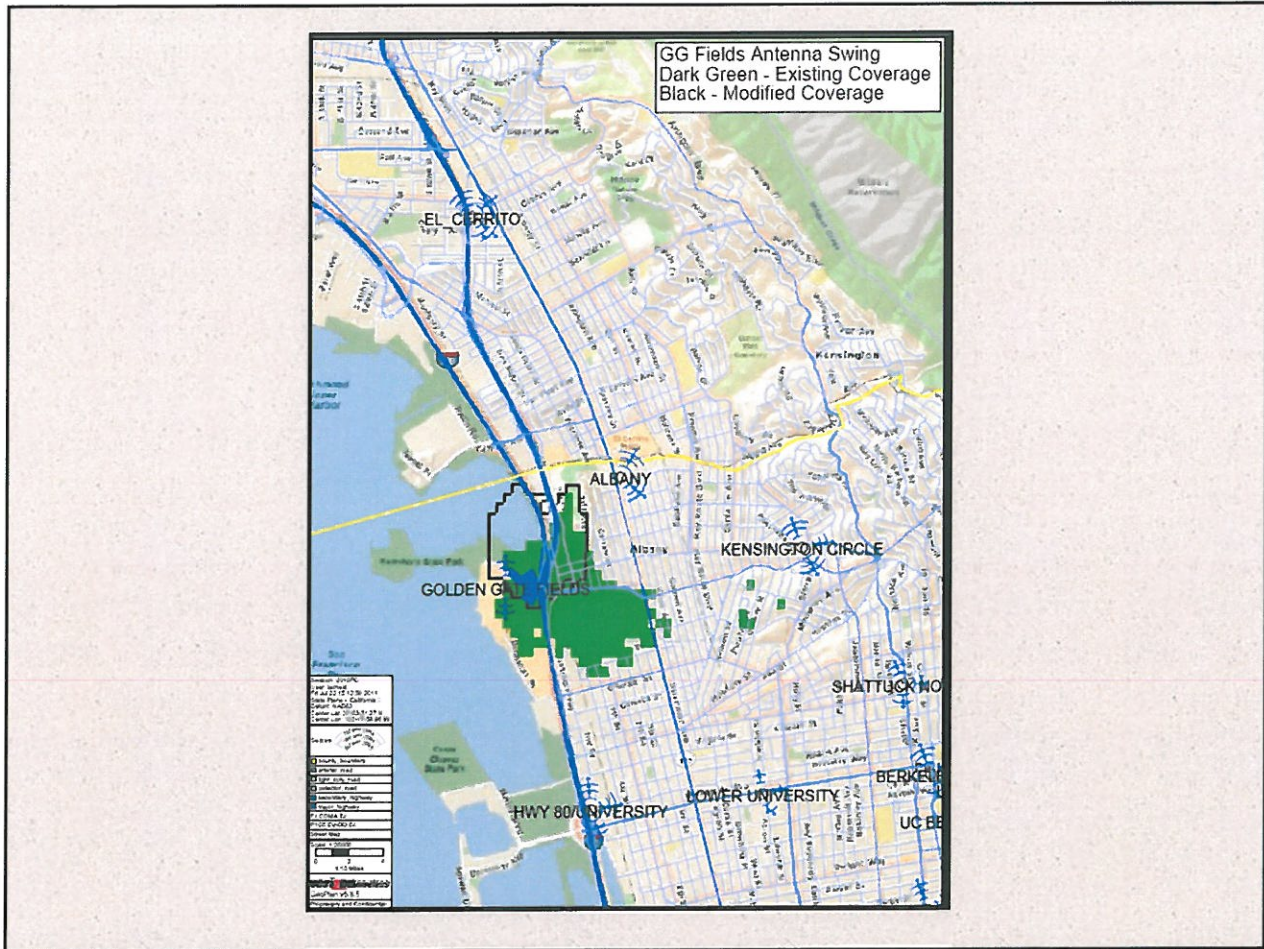

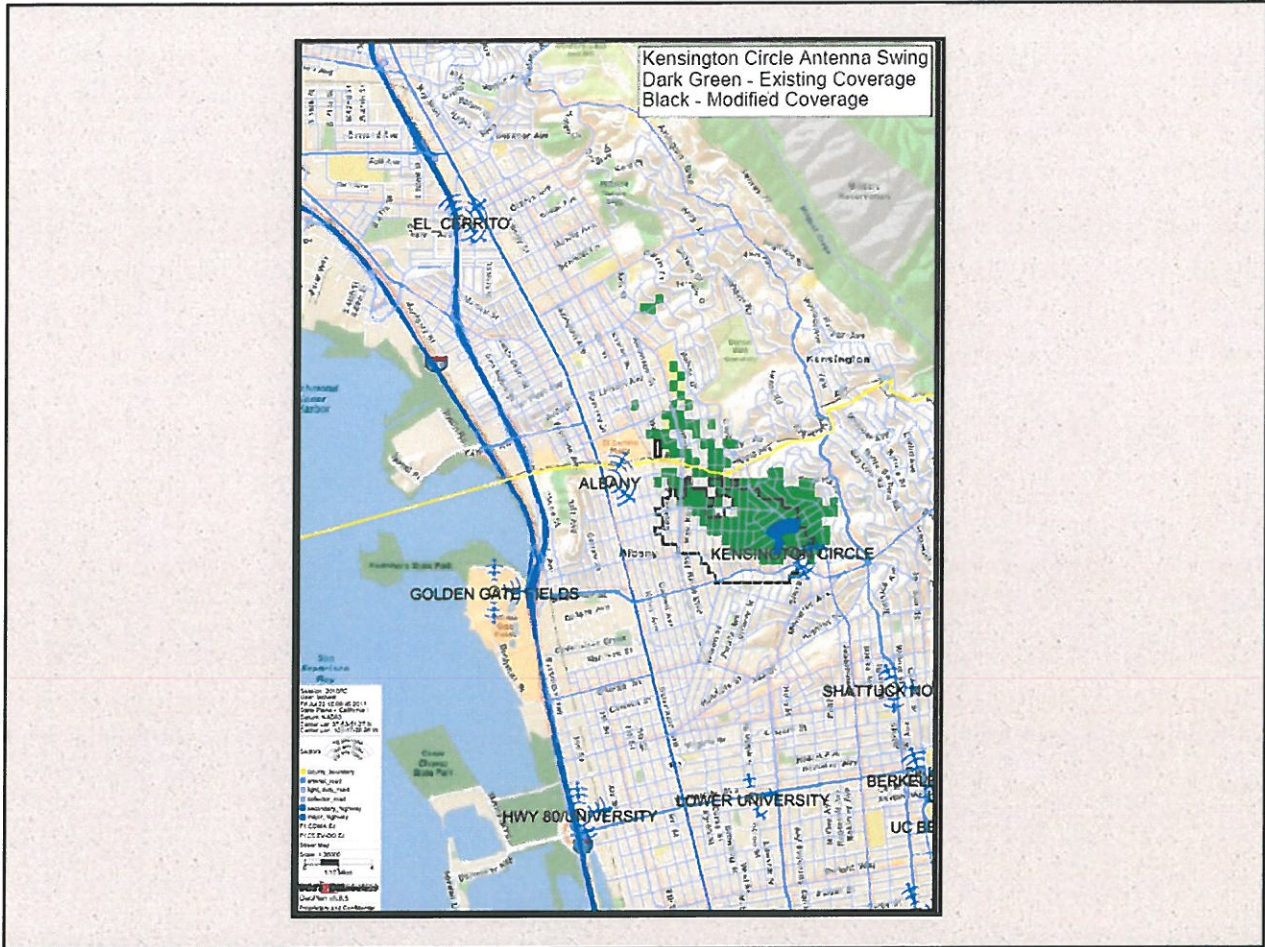



Crown Site -Kensington (880503)

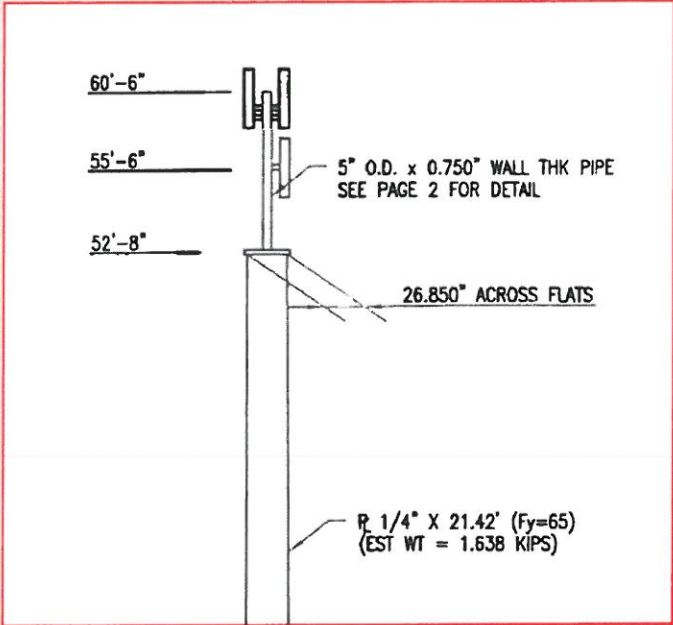

Additional Design Considerations For Existing Albany Site

- Replace Existing Mounting Brackets to Achieve “Tighter” Configuration
- Repaint Pole
- Repaint Panels

Conclusion

- Strict compliance (reducing the pole height to 48 feet) will not provide for adequate radio-frequency signal reception
- Other alternative solutions discussed tonight do not meet coverage and capacity objectives (replace panels and improve coverage)
- The proposed Project complies with the municipal code because it minimizes stand-alone facilities by replacing the existing panels with panels of a similar shape and size, rather than requiring construction of an additional facility